

Application

The compli 300 E is the smallest sewage lifting station of our compli series. It has been designed for the disposal of sewage from housing units like basement dwellings. The compli 300 E is all-purposed, due to compact dimensions of its tank and numerous connection facilities.

The low weight and the plug with integrated control board ensures a facile installation, so that an electrician is not needed to start running the unit.

The submersible unit permits a general application in rooms which could be flooded.

The connector housing with integrated control unit must be installed in rooms which are well ventilated and cannot be flooded.

The powerful alternating current motor of the compli 300 is based on a rugged grey cast iron volute housing vat which grant a special stability and quiet running.



新法機械有限公司
NEW WAY ENGINEERING CO., LTD.
 香港九龍新蒲崗六合街8號六合工業大廈22字樓F座
 FLAT F, 22/F., LUK HOP INDUSTRIAL BUILDING,
 8 LUK HOP STREET, SAN PO KONG, KOWLOON, H.K.
 Tel : 2325 6892, 2325 7196 Fax No.: (852) 2322 1768
 E-mail : info@newway.com.hk

Performance

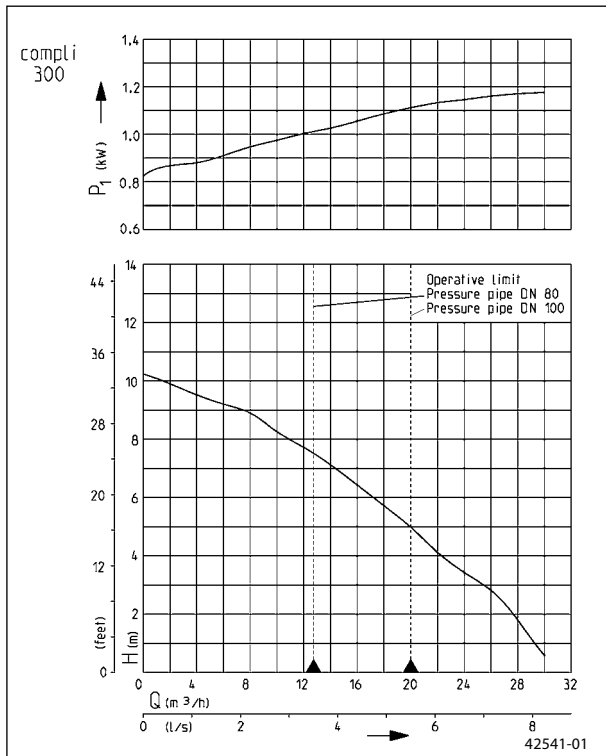

- Ready to connect
- Submersible
- Auxiliary inlets vertical/horizontal
- Light weight
- Less place requirement
- PE-tank
- Vortex impeller



We reserve the right to change specifications without notice
 Pump performance is subject to ISO 9906 tolerances
 The minimum flow velocity in the pressure piping must be 0.7 m/s according to EN 12056.
 This data is represented in the performance curve as a limit of application.

Sewage lifting station

Type	Tank capacity l	Floor to centre inlet mm	Free passage mm	Inlet flange	Vent pipe	Weight ca.	Code No.
compli 300 E	ca. 50	180	50	DN 100	DN 70	29 kg	09496

Performance

Type	Delivery head H [m]	1	2	3	4	5	6	7
compli 300 E	Flow rate Q [m ³ /h]	29	28	25	22	20	17	14

Elektrical data

Type	Type of current	Voltage Volt	Motorrating kW P ₁ P ₂	RPM min ⁻¹	F.L.C. Ampere	Cable (4 m)	Plug
compli 300 E	1-phase	1/N/PE~230	1.25 0.94	2700	6.0	S07RN-F-4G0.75	Safety-

Mounting arrangement

Direct connection in an adjoining room, for a space-saving installation. Additional drainage facilities can be connected to the auxiliary inlet.

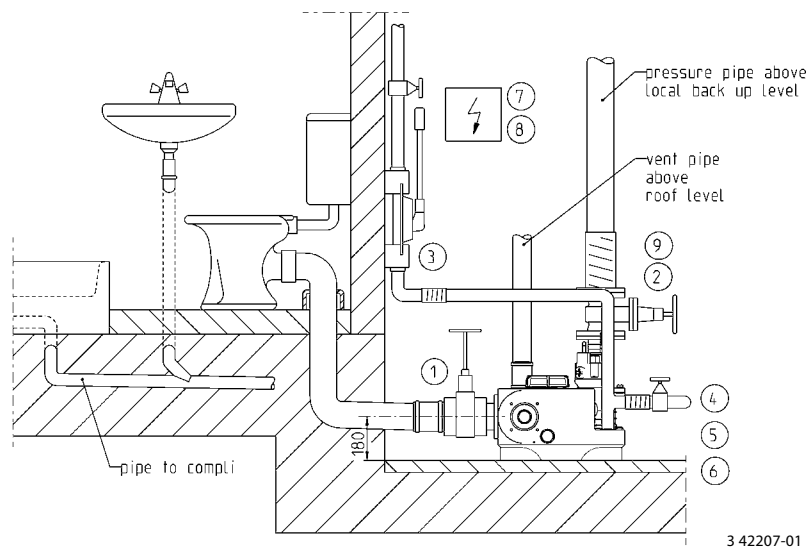
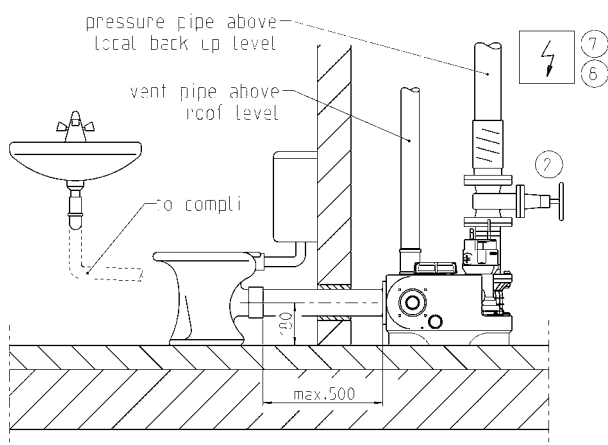

The compli 300 has a DN 80/PN 4 outlet flange. The following stop valve and pipework are installed in DN 80.



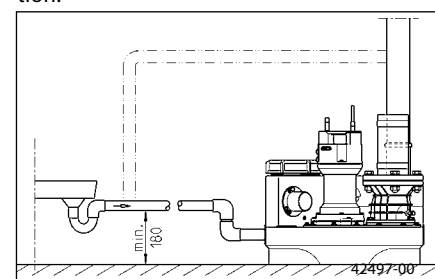

In keeping with the construction and testing principles of German / European standard DIN EN 12050, sewage lifting stations are to be used for the transport of faecal matter and domestic waste-water in building drainage systems as described in German standard DIN 1983 T3. In keeping with the stipulations of German / European standard DIN EN 12056-4 they have to be mounted with collecting tanks inside building permitting a free space of 60 cm for operation and repair. The pressure pipe has to be passed above the locally defined backpressure level and a non-return valve tested in keeping with German / European standard 12050-4 has to be mounted. In keeping with German / European standard 12056 the ventilation pipe has to be passed up to the roof.

DIN EN 12056 paragraph 5.1 In applications where the waste-water inlet must not be interrupted a double system has to be installed.

Attention! The inlet pipes of the low lateral inlets must be equipped with a dam loop. This loop must have at least a height of 180 mm between ground and invert. The feed line must be ventilated on its highest elevation.

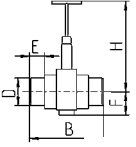
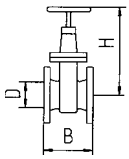
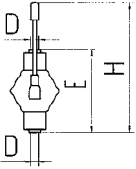
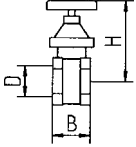
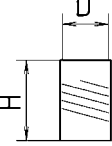

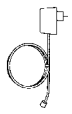
Accessories

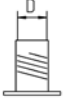
					Art.-Nr.
	①	PVC sluice valve (2 pipe sockets) for inlet 4" (DN 100), PN 1	$\frac{H}{360} \quad \frac{B}{295} \quad \frac{E}{60} \quad \frac{F}{81} \quad \frac{D}{110}$		28297
	②	Sluice valve-GG* for discharge pipe 3" (DN 80), PN 10, DIN EN 1171	$\frac{H}{315} \quad \frac{B}{180} \quad \frac{D}{DN 80}$ for inlet 3"		00639
	③	Hand diaphragm pump for emergency purpose (for max. del. height up to H_{geod} 15 m)	$\frac{H}{ca. 640} \quad \frac{E}{430} \quad \frac{D}{1\frac{1}{2}''}$		00255
	④	Stop valve, 1½" (DN 40), PN 16	$\frac{H}{125} \quad \frac{B}{max. 60} \quad \frac{D}{1\frac{1}{2}''}$		11837
	⑤	Elastic connection 1½" (DN 40), PN 4	$\frac{H}{120} \quad \frac{D}{50}$		20368
	⑥	Hose band clamp 1½"			03571
	⑦	Alarm system separate mainsdependent, with potential free contact and 3 m cable			20198
	⑧	Rechargeable battery for off the line operation alarm system			07562
	⑨	Pipe work connection set DN 100	$\frac{D}{110}$		42910

* with screws and gaskets

Technical data

Pump

Vertical, single-stage, submersible, vortex impeller, vortex casing with vertical discharge DN 80, flanged to PE-tank with cleaning aperture.

Bearing

Common shaft for pump and motor, greased ball bearings.

Seal

Two radial-lip seals.

Motor

Submersible, type of enclosure IP 68, insulation class B, winding thermostats for motor protection, automatic starting via level control and control unit, power supply via safety-plug, S3 type of operation in keeping with German standard VDE.

Materials

Tank made of corrosion resistant and non-polluting Polyethylene, Pump - and pumpmotor housing from grey cast iron and stainless steel, vortex impeller made GFK, shaft stainless steel, supply through rubber insulated flexible cable.

Scope of supply

Ready to connect sewage disposal unit acc. to DIN EN 12050-1 with clamp flange DN 100 for inlet height 180 mm, additional inlets DN 100/50 horizontal and vertical, submersible pump and flange DN 80 with piece of pipe \varnothing 90 mm, with integrated swing-type check valve DN 80, one elastic connection hose band clamps for plastic pipe DN 80 and for pressure pipe DN 70, autom. level control, control unit (type of enclosure IP 44) with mains-dependent alarm buzzer, stand-by LED, hand-0-automatic selector switch and potential free NO contact for an additional alarm.

Accessories to be ordered according to the mounting drawing.

Standard DIN EN 12056-4, paragraphs 5.1 and 5.2

- Working area of 60 cm above and around all parts that have to be operated.
- Pump sump for the drainage of the operation room
- Swing-type check valve on the pressure side
- Stop valve on the pressure side
- Stop valve on the inlet side
- Disposal units have to be mounted buoyancy-proof

Dimensions with swing-type check valve (mm)

