

Catalog D 86.1 · 2007



新法機械有限公司  
 NEW WAY ENGINEERING CO., LTD.  
 香港九龍新蒲崗六合街8號六合工業大廈22字樓F座  
 FLAT F, 22/F., LUK HOP INDUSTRIAL BUILDING,  
 8 LUK HOP STREET, SAN PO KONG, KOWLOON, H.K.  
 Tel : 2325 6892, 2325 7196 Fax No.: (852) 2322 1768  
 E-mail : info@newway.com.hk

# ac motors LARGE DRIVES



Asynchronous Motors  
Standardline

N-compact 1LA8  
H-compact 1LA4



## Catalogs for „Large Drives“

**SINAMICS G130/G150** D 11  
SINAMICS G130 Drive Converter Chassis Units  
SINAMICS G150 Drive Converter Cabinet Units

Order No.:  
German: E86060-K5511-A101-A3  
English: E86060-K5511-A101-A3-7600



**Low-Voltage Motors** D 81.1  
**IEC Squirrel-Cage Motors**  
**Frame sizes 56 to 450**  
**Power range 0.06 kW to 1250 kW**

Order No.:  
German: E86060-K5581-A111-A1  
English: E86060-K5581-A111-A1-7600



**Three-phase synchronous motors** D 86.2  
**HT-direct 1FW4**

Order No.:  
German: E86060-K5586-A121-A2  
English: E86060-K5586-A121-A2-7600



**Catalog CA 01** CA 01  
**the Offline Mall of**  
**Automation and Drives**

Order No.:  
German: E86060-D4001-A100-C5  
English: E86060-D4001-A110-C5-7600



### A&D Mall

Internet:  
[www.siemens.com/automation/mall](http://www.siemens.com/automation/mall)



## Energy-saving program SinaSave™

Energy is valuable. Electrical power is the most important resource in industry and ensures that motors run, machines operate and plants manufacture.

Our SinaSave software tool can show you how fast an investment in an EFF1 energy-saving motor or a frequency drive amortizes. Based on your plant characteristics, the program determines how much energy you'll save in the specific application case. The amortization period is calculated based on the overall monthly savings and the purchase price of the motor or frequency drives. The amortization period often lasts for just a few months.

The SinaSave energy-saving program has been developed for applications with motors in direct online operation (fixed speed) and in frequency drive operation (variable speed). With fixed speed, cost savings and payback time of the higher motor price for Siemens EFF1 energy-saving motors can be calculated based on the following three cases. Compared to...

- Siemens EFF2 energy-saving motors - **Case 1**
- Individually selected known motors - **Case 2**
- Known motors within the framework of a complete plant analysis - **Case 3**

With variable speed, SinaSave considers all required system-specific parameters. Values required for the process are considered, such as flow rate and delivery head of pumps, mass flow rate and total pressure drop on fans and the density of the delivered medium, as well as the efficiency of the pumps and compressors, the electrical efficiency and the overall efficiency of the plant. Further basic data used by the program is the number of workdays and work shifts as well as the daily and annual output profile, which is decisive with respect to the energy savings effect.

First of all, the program uses the plant-specific basic data entered, to determine the drive system with the required output, and the price of a suitable frequency drive. In another step, the program determines the energy demand of the variable-speed drive system for the specific application and compares it with the calculated values of all possible alternative concepts for the respective plant, such as throttle valves, bypass, pre-rotation control or pole-changing motors. Energy savings in kilowatt hours are derived from the resulting difference. The program converts this difference into actual cash value based on the currently valid power supply price for the plant.

The program calculates the payback period considering the price of the frequency drives, the decisive energy savings, and other cost-cutting effects of the variable-speed operation, such as improved power factor and machine-friendly operation.

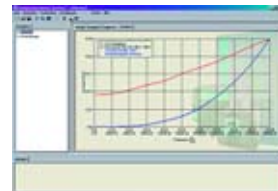

### Further information and download of SinaSave:

[www.siemens.com/energysaving](http://www.siemens.com/energysaving)

# Asynchronous Motors Standardline

N-compact 1LA8  
H-compact 1LA4

Catalog D 86.1 · 2007

Supersedes:  
Catalog D 86.1 · 2005

The products in this catalog  
(except for High-Voltage Motors)  
are also included in the  
electronic catalog CA 01  
Order No.:  
E86060-D4001-A110-C5-7600 (CD-ROM)  
E86060-D4001-A510-C5-7600 (DVD)

Contact your local Siemens  
representative for further information

© Siemens AG 2007



*The products and systems described in this catalog are manufactured/distributed under application of a certified quality management system in accordance with DIN EN ISO 9001. The certificate is recognized by all IQNet countries.*



# SIEMENS

## Introduction

Products of A&D  
Overview and  
preselection of  
Standardline three-phase  
AC asynchronous motors

1

## Low-Voltage Motors N-compact

Operation on  
supply system

### Standardline

Operation with  
converter

2

3

## High-Voltage Motors H-compact

Operation on  
supply system

### Standardline

4

## Appendix

Contacts  
A&D Online Services  
Service & Support  
Conditions of sale  
and delivery

5

# Siemens Automation and Drives. Welcome

More than 70,000 people aiming for the same goal: increasing your competitiveness. That's Siemens Automation and Drives.

We offer you a comprehensive portfolio for sustained success in your sector, whether you're talking automation engineering, drives or electrical installation systems. Totally Integrated Automation (TIA) and Totally Integrated Power (TIP) form the core of our offering. TIA and TIP are the basis of our integrated range of products and systems for the manufacturing and process industries as well as building automation. This portfolio is rounded off by innovative services over the entire life cycle of your plants.

Learn for yourself the potential our products and systems offer. And discover how you can permanently increase your productivity with us.

Your regional Siemens contact can provide more information. He or she will be glad to help.



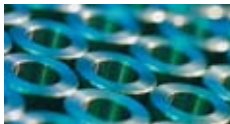
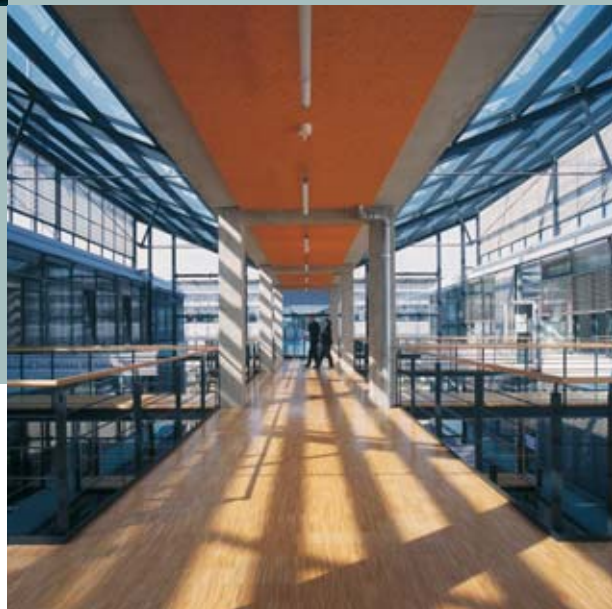

# Sharpen your competitive edge. Totally Integrated Automation

With Totally Integrated Automation (TIA), Siemens is the only manufacturer to offer an integrated range of products and systems for automation in all sectors - from incoming goods to outgoing goods, from the field level through the production control level to connection with the corporate management level.

On the basis of TIA, we implement solutions that are perfectly tailored to your specific requirements and are characterized by a unique level of integration. This integration not only ensures significant reductions in interface costs but also guarantees the highest level of transparency across all levels.

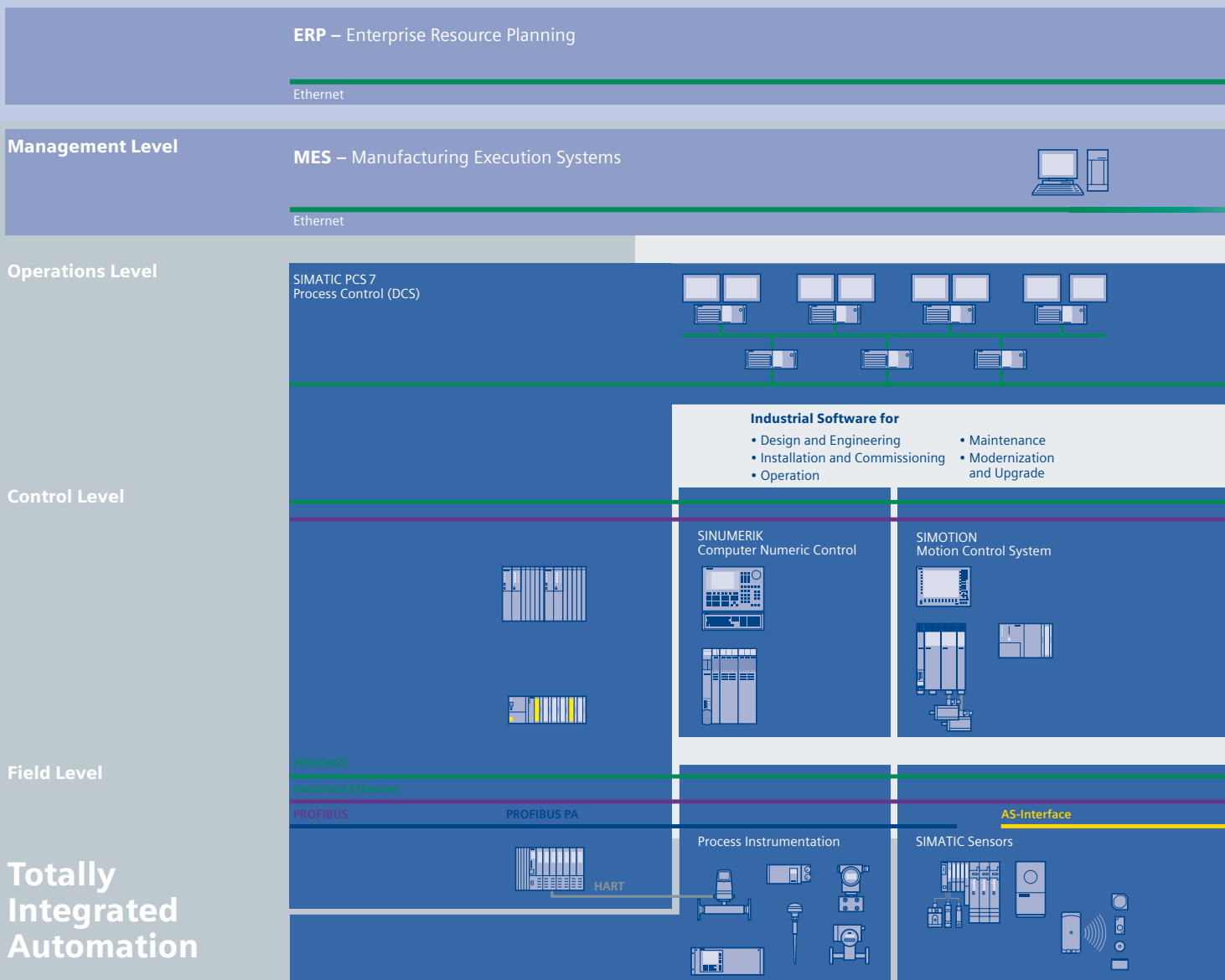

It goes without saying that you profit from Totally Integrated Automation during the entire life cycle of your plants - from the first planning steps, through operation, right up to modernization. Consistent integration in the further development of our products and systems guarantees a high degree of investment security here.

Totally Integrated Automation makes a crucial contribution towards optimizing everything that happens in the plant and thus creates the conditions for a significant increase in productivity.

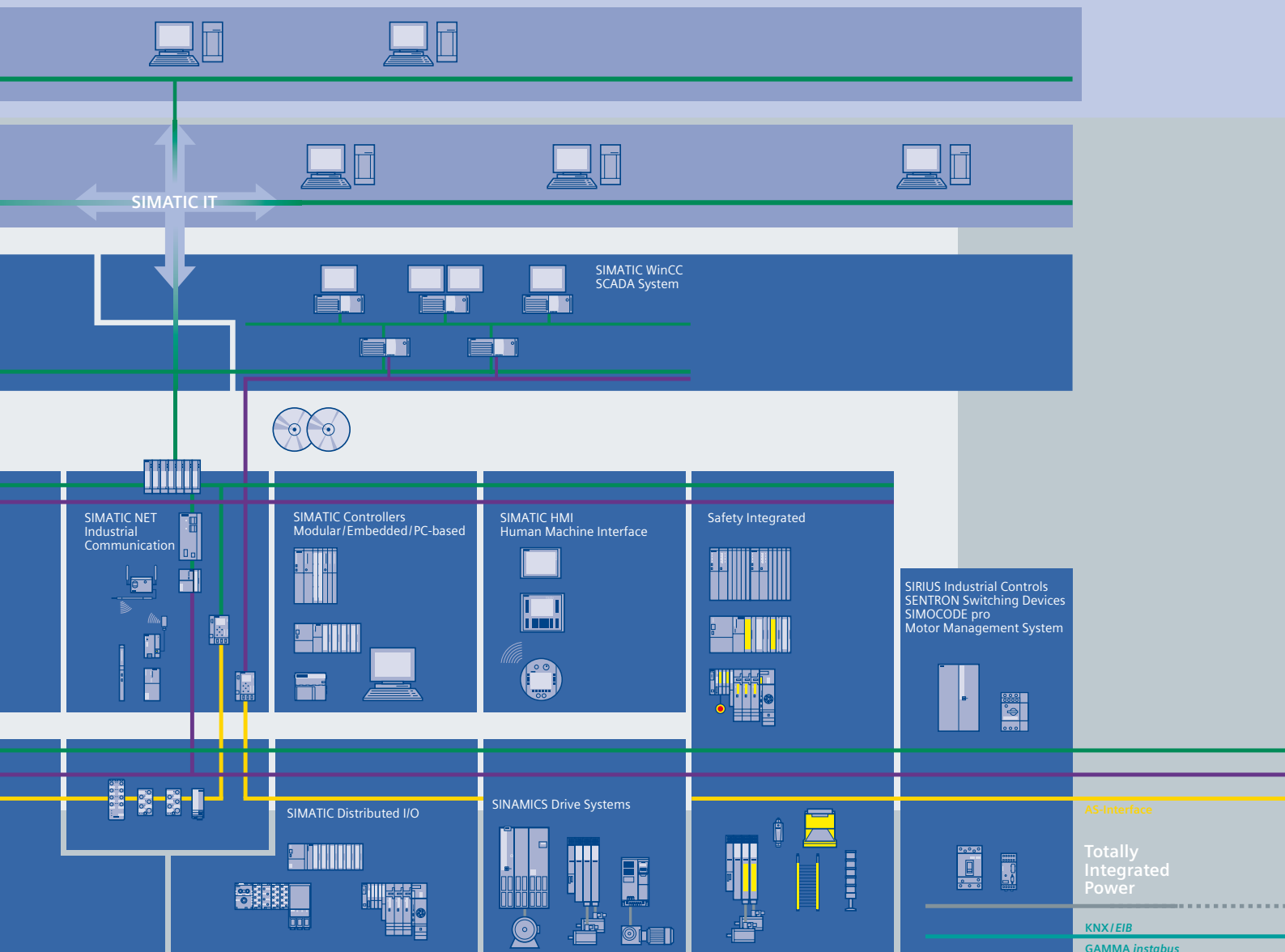

# Integrated energy distribution from a single source. Totally Integrated Power

Totally Integrated Power (TIP) brings together all the components of electrical energy distribution into an integrated whole. Thus TIP provides the answer to growing market demands in the planning, construction and use of utility buildings and industrial buildings.

On the basis of TIP, we offer integrated solutions for energy distribution, from medium voltage to the power outlet. Totally Integrated Power is based here on integration in planning and configuring as well as on perfectly matched products and systems.

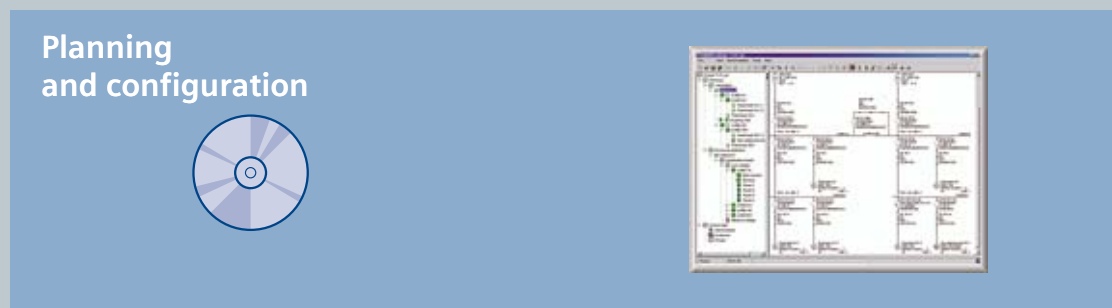
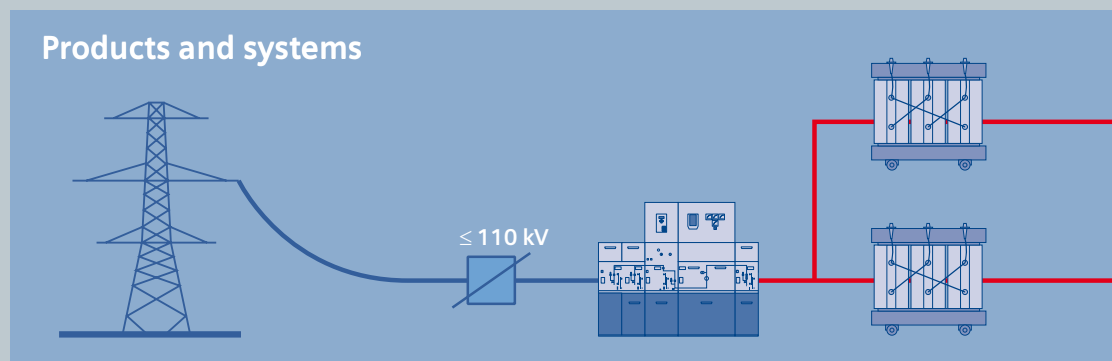
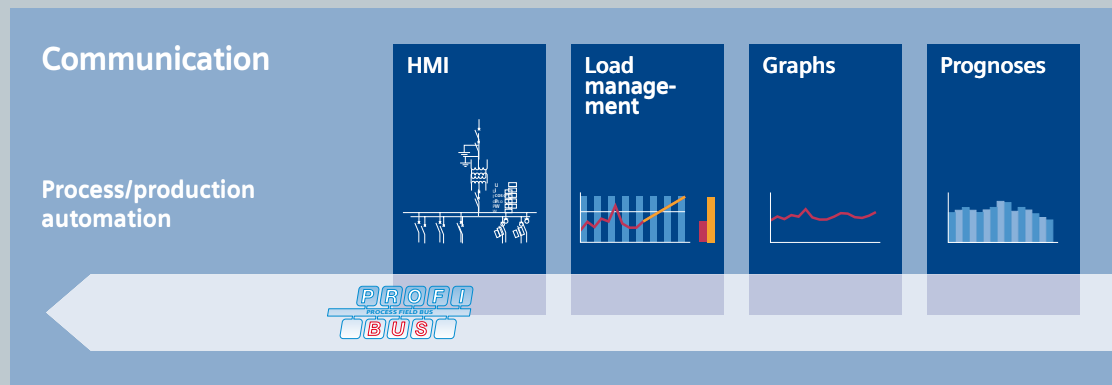

Totally Integrated Power offers communication and software modules for connecting the energy distribution systems to industrial automation and building automation. This enables the implementation of significant savings potential.

r

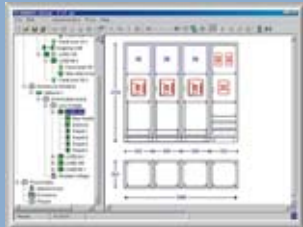
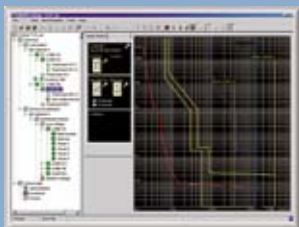
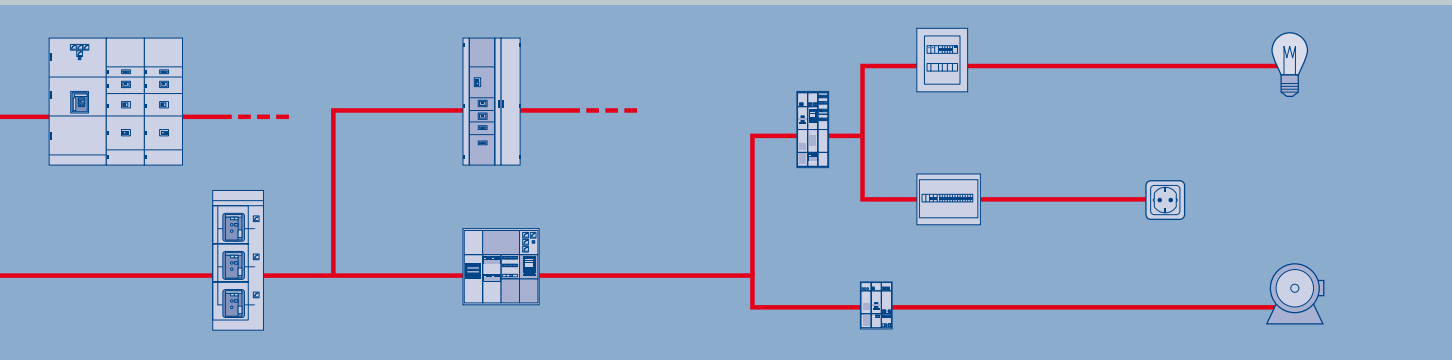
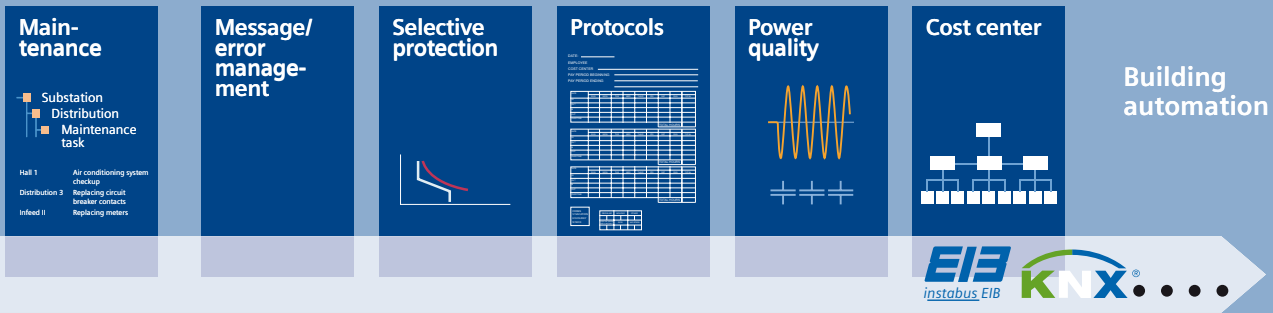

## Asynchronous Motors Standardline

### Overview

Complete drive systems can be selected and configured simply in this catalog.

The following variants of Standardline N-compact and H-compact motors are available:

- Type of construction: IM B3
- Degree of protection: IP55
- Cooling method: IC 411

Motor	Operation	Rated voltage	Power range	Pole number	Catalog section
<b>N-compact 1LA8 low-voltage</b>	<b>on supply system</b>	400 V $\Delta$ /690 V $\Upsilon$ , 50 Hz 500 V $\Delta$ , 50 Hz	250 ... 500 kW	4-pole	<b>2</b>
	<b>with SINAMICS G150 converter</b>	400 V $\Delta$ , 50 Hz 400 V $\Delta$ /690 V $\Upsilon$ , 50 Hz 500 V $\Delta$ , 50 Hz	250 ... 500 kW	4-pole	<b>3</b>
<b>H-compact 1LA4 high-voltage</b>	<b>on supply system</b>	3.0 kV, 50 Hz 3.3 kV, 50 Hz 6.0 kV, 50 Hz 6.6 kV, 50 Hz	200 ... 800 kW	2-pole, 4-pole and 6-pole	<b>4</b>

### Benefits

#### *Standardline – large-drive technology kept simple*

The Standardline range provides a family of high-voltage and low-voltage motors which have been standardized to minimize product complexity.

Benefits to the customer:

- Sophisticated technology - available quickly
- Products in the Standardline range can be configured with a variety of options so as to ensure a high degree of flexibility.

### Application

Standardline high-voltage and low-voltage motors are ideally designed for application in pump, fan and compressor drives.

The low-voltage motors are specially constructed for use in complete, coordinated drive systems comprising the motor and a SINAMICS G150 frequency converter.

### More information

#### *H-compact*

- in Sales Brochures:
  - H-compact  
Maximum power, minimum size  
Order No. E20001-A100-P530-X-7600
  - H-compact Standardline  
Outstanding performance, short delivery time  
Order No. E20001-A130-P530-X-7600
- on the Internet: [www.siemens.com/h-compact](http://www.siemens.com/h-compact)

#### *N-compact*

- in Sales Brochures:
  - N-compact  
Higher performance and cost-effectiveness with outstanding reliability  
Order No. E20001-A80-P530-X-7600
- in Catalog D 81.1:  
Order No. E86060-K5581-A111-A1-7600
- on the Internet: [www.siemens.com/n-compact](http://www.siemens.com/n-compact)
- in Online Catalog CA 01: [www.ad.siemens.com/ca01](http://www.ad.siemens.com/ca01)

#### *SINAMICS G150*

- in the System Overview:  
SINAMICS - The New Drive Family  
Order No. 6ZB5471-0AB02-0BA2
- in Catalog D 11:  
Order No. E86060-K5511-A101-A3-7600
- on the Internet: [www.siemens.com/sinamics-g150](http://www.siemens.com/sinamics-g150)

# Low-Voltage Motors N-compact **Standardline** Operation on supply system

# 2



<b>2/2</b>	<b>Overview</b>
<b>2/2</b>	<b>Benefits</b>
<b>2/2</b>	<b>Technical specifications</b>
<b>2/2</b>	<b>Selection and Ordering Data</b>
<b>2/3</b>	<b>Options</b>
<b>2/3</b>	<b>Dimensional drawings</b>
<b>2/4</b>	<b>More information</b>
2/4	Power cables



# Low-Voltage Motors N-compact Standardline

## Operation on supply system

### Overview

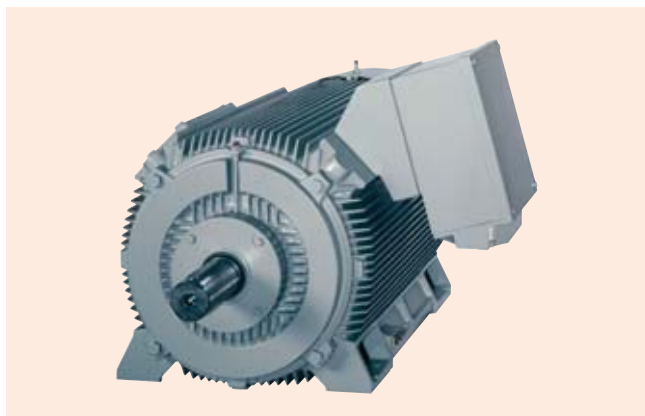

The N-compact series sets the modern worldwide standard for large three-phase low-voltage motors. Many details of the motors' design make them durable and so robust that they are always capable of withstanding extreme stresses.

In terms of technical design, the N-compact Standardline series is identical to the familiar 1LA8 N-compact motors which are described in Catalog D 81.1 (Order No. E86060-K5581-A111-A1-7600).

Standardline is intentionally designed to focus the N-compact series on meeting the requirements of drives for pumps, fans and compressors:

- Power range 250 to 500 kW
- Supply voltages 400 V, 500 V and 690 V at a frequency of 50 Hz
- 4-pole
- Type of construction IM B3

### Benefits

Standardization has made it possible to further optimize order handling and production processes.

Benefits to the customer:

- Significant reduction in delivery time to only 4 weeks
- State-of-the-art technology and quality which is already in use worldwide

### Technical specifications

Further information about general technical data and the design and construction of the N-compact motor series can be found in Catalog D 81.1 (Order No. E86060-K5581-A111-A1-7600) and in the electronic Catalog CA 01 on CD-ROM (Order No. E86060-D4001-A110-C5-7600).

### Selection and Ordering Data

Type IM B3, degree of protection IP55, temperature class F, utilization in accordance with temperature class B

Rated power kW	Order No. + order codes for further options	Operating values at rated output						Starting torque with direct starting torque	Starting current as multiple of rated current	Stalling torque	Torque class CL	Moment of inertia J kgm <sup>2</sup>
		Rated speed rpm	Efficiency $\eta$ with 4/4 load %	3/4 load %	Power factor $\cos \varphi$	Rated current at 400 V A	Rated torque Nm					
<b>3AC 400 V, 50 Hz</b>												
<b>1500 rpm, 4-pole</b>												
250	1LA8315-4AB 0-Z + B20	1488	96.0	96.0	0.88	425	1600	1.9	6.5	2.8	13	3.6
315	1LA8317-4AB 0-Z + B20	1488	96.3	96.3	0.88	540	2020	2.0	6.8	2.8	13	4.4
355	1LA8353-4AB 0-Z + B20	1488	96.3	96.3	0.87	610	2280	2.1	6.5	2.6	13	6.1
400	1LA8355-4AB 0-Z + B20	1488	96.4	96.4	0.87	690	2570	2.1	6.5	2.6	13	6.8
500	1LA8357-4AB 0-Z + B20	1488	96.8	96.8	0.88	850	3210	2.1	6.5	2.4	13	8.5
Voltage distinctive number:												
400 V $\Delta$ /690 V $\Upsilon$ — 6												
500 V $\Delta$ — 5												

Ordering example:

Low-voltage motor  
N-compact Standardline basic version  
400 V $\Delta$ , 50 Hz, 1500 rpm, 4-pole, 355 kW  
with option K45: Anti-condensation heating for 230 V

**1LA8353-4AB60-Z  
+B20+K45**

### Options

Option description	Order code	Comment
Standardline design	<b>B20</b>	Always state
Motor temperature sensing by KTY 84-130 temperature sensor	<b>A23</b>	
Motor temperature sensing by 6 PT100 resistance thermometers	<b>A61</b>	In basic circuit
2 screw-in PT100 resistance thermometers in basic circuit for rolling-contact bearings	<b>A72</b>	
Measuring nipple for SPM shock pulse measurement for bearing inspection	<b>G50</b>	
Connection box on RHS (view onto DE)	<b>K09</b>	Standard
Connection box on LHS (view onto DE)	<b>K10</b>	
Anti-condensation heating for 230 V	<b>K45</b>	
Anti-condensation heating for 115 V	<b>K46</b>	
Cable entry, maximum configuration	<b>K57</b>	
Rotation of the connection box through 90°, entry from DE	<b>K83</b>	
Rotation of the connection box through 90°, entry from NDE	<b>K84</b>	
Rotation of the connection box through 180°	<b>K85</b>	
Next larger connection box 1XB1 631	<b>L00</b>	
Auxiliary connection box 1XB3 020	<b>L97</b>	
Auxiliary connection box 1XB9 014	<b>M88</b>	
Next larger connection box 1XB1 621 with shaft height 315	<b>M58</b>	The next larger size of connection box is recommended when cables with cross sections >185 mm <sup>2</sup> are installed for motors with shaft height 315.
Standard paint finish in a color different from RAL 7030	<b>Y53</b>	Plain text required

### Dimensional drawings

#### Design:

Type IM B3, rolling-contact bearing, degree of protection IP55, cooling method IC 441

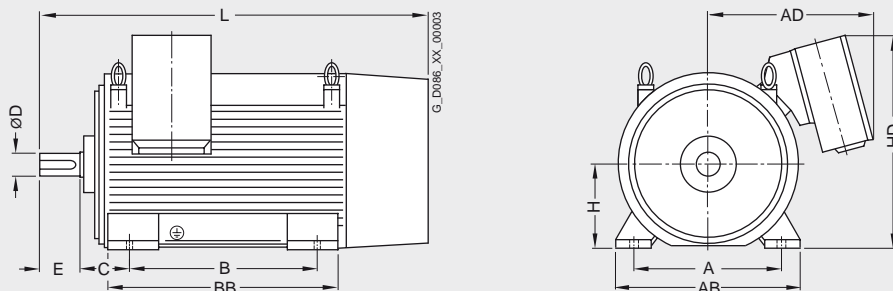

Type	Weight approx. kg	A mm	AB mm	AD mm	B mm	BB mm	C mm	H mm	HD mm	L mm	D mm	E mm
<b>4-pole</b>												
<b>1LA8315-4AB.0</b>	1300	560	680	570	630	780	180	315	825	1410	85	170
<b>1LA8317-4AB.0</b>	1500	560	680	570	630	780	180	315	825	1410	85	170
<b>1LA8353-4AB.0</b>	1900	630	780	710	800	980	200	355	905	1635	95	170
<b>1LA8355-4AB.0</b>	2000	630	780	710	800	980	200	355	905	1635	95	170
<b>1LA8357-4AB.0</b>	2200	630	780	840	800	980	200	355	945	1635	95	170

For further information see Catalog D 81.1 (Order No. E86060-K5581-A111-A1-7600).

# Low-Voltage Motors N-compact Standardline

## Operation on supply system

### More information

#### Power cables

As specified in the table below, parallel feeders are required to connect the motors (see also Catalog D 81.1, Part 1 "Motor connection and connection boxes", "Parallel feeders"):

Voltage	1LA8 . . .				
	315	317	353	355	357
400 V	•	•	•	•	•
500 V			•	•	

2

# Low-Voltage Motors N-compact **Standardline** Operation with converter

# 3



<b>3/2</b>	<b>Overview</b>
3/2	Variable-speed drive systems for 400 V and 500 V
<b>3/2</b>	<b>Benefits</b>
<b>3/2</b>	<b>Configuration</b>
<b>3/2</b>	<b>Technical specifications</b>
<b>3/3</b>	<b>Selection and Ordering Data</b>
<b>3/3</b>	<b>Options</b>
3/3	N-compact Standardline motor
3/3	Relevant options with SINAMICS G150
3/4	Further converter options
<b>3/5</b>	<b>Dimensional drawings</b>
<b>3/9</b>	<b>More information</b>
3/9	Power cables



## Operation with converter

### Overview

Variable-speed drive systems for 400 V and 500 V

**N-compact Standardline motors with SINAMICS G150 frequency converter**



SINAMICS G150 converter cabinet units are designed for use in variable-speed drives in machine construction and plant engineering. They offer a low-cost drive solution which can be flexibly tailored from a wide spectrum of components and options to meet the requirements of individual customers.

A detailed description of the SINAMICS G150 converter series can be found in Catalog D 11 (Order No. E86060-K5511-A101-A3-7600), Part 3.

N-compact Standardline 1LA8 low-voltage motors and SINAMICS G150 frequency converters combine to make an ideally coordinated system for variable-speed drives specially tailored for operating pumps, fans and compressors (square-law characteristic):

- Power range 250 to 500 kW
- Supply voltages 400 V and 500 V, 50 Hz
- 4-pole motor
- Motor type IM B3

### Benefits

Benefits to the customer:

- The complete system can be delivered within 4 weeks.
- Optimally coordinated drive system
- Economical drive solution
- Easy to customize

### Configuration

With the motor - converter combination (selection and ordering data), the drive can be operated under both "low overload" and "high overload" on the basis of the motor drive power (for exceptions, see selection and ordering data, footnotes 3 to 5).

Note about "Low/high overload":

The rated output current of the converter equals the maximum permissible current for continuous operation (without overload).

If the converter must be capable of handling overload conditions such as breakaway torques or shock loads, a base load current determined according to the duty cycle must be applied to calculate the converter rating.

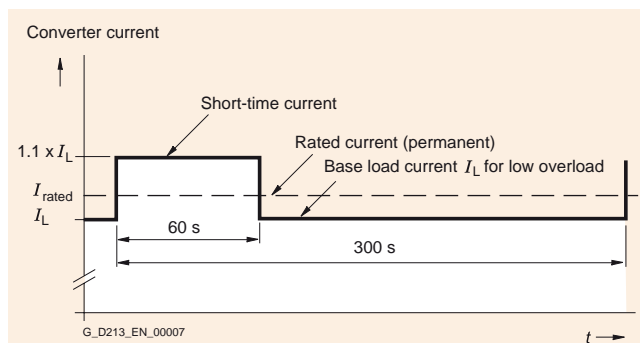

Low overload

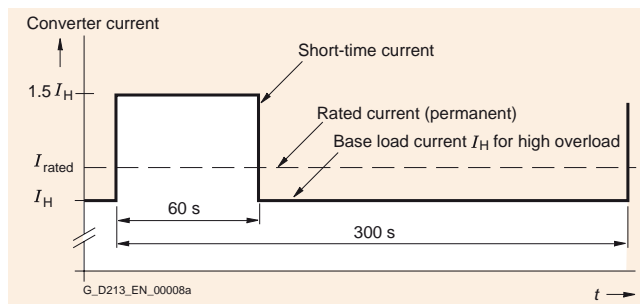

High overload

The diagrams show the duty cycles for two different conditions, i.e. "low overload" and "high overload", with the resulting base load currents  $I_L$  and  $I_H$ .

"Low overload" is defined as a 300 s duty cycle in which the converter may operate at 110% of the base load current  $I_L$  for 60 s, or at 150% for 10 s (not illustrated).

"High overload" is defined as a 300 s duty cycle in which the converter may operate at 150% of the base load current  $I_H$  for 60 s, or at 160% for 10 s (not illustrated).

The converter may be operated under the appropriate overload conditions only if the base load current is not exceeded within the duty cycle either before or after the overload phase.

### Technical specifications

Further information about general technical data and the design of the SINAMICS G150 converter series can be found in Catalog D 11 (Order No. E86060-K5511-A101-A3-7600) and in the electronic Catalog CA 01 on CD-ROM (Order No. E86060-D4001-A110-C5-7600).

### Selection and Ordering Data

The following drive systems (motor + converter) are recommended for applications with square-law load torque.

Drive power <sup>1)</sup> kW	N-compact motor		SINAMICS G150 converter variant A <sup>2)</sup>	
	Order No. + order codes for further options	Rated current A	Order No. for converter options Order No. with -Z + Order codes	Rated output current A
<b>3AC 400 V Δ, 50 Hz</b>				
<b>1500 rpm, 4-pole</b>				
250	1LA8315-4PB80-Z + B20	430	6SL3710-1GE35-0AA0	490
315	1LA8317-4PB80-Z + B20	540	6SL3710-1GE36-1AA0	605
355	1LA8353-4PB80-Z + B20	610	6SL3710-1GE37-5AA0	745
400	1LA8355-4PB80-Z + B20	690	6SL3710-1GE37-5AA0 <sup>3)</sup>	745
500	1LA8357-4PB80-Z + B20	850	6SL3710-1GE41-0AA0	985
<b>3AC 500 V Δ, 50 Hz</b>				
<b>1500 rpm, 4-pole</b>				
250	1LA8315-4PB50-Z + B20	340	6SL3710-1GF34-1AA0	410
315	1LA8317-4PB50-Z + B20	432	6SL3710-1GF34-7AA0 <sup>4)</sup>	465
355	1LA8353-4PB50-Z + B20	488	6SL3710-1GF35-8AA0	575
400	1LA8355-4PB50-Z + B20	552	6SL3710-1GF37-4AA0	735
500	1LA8357-4PB50-Z + B20	680	6SL3710-1GF37-4AA0 <sup>5)</sup>	735
<b>3AC 690 V Y, 50 Hz</b>				
<b>1500 rpm, 4-pole</b>				
250	1LA8315-4PB80-Z + B20	283	SINAMICS S 150 converters for 690 V motors are not part of the Standardline program. For operating the listed 690 V motors on the SINAMICS converter, the converter has to be ordered with option L10 (du/dt filter). For Selection and Ordering Data, see Catalog D 11.	
315	1LA8317-4PB80-Z + B20	360		
355	1LA8353-4PB80-Z + B20	406		
400	1LA8355-4PB80-Z + B20	460		
500	1LA8357-4PB80-Z + B20	566		

- Temperature class F, utilization in accordance with F. The drive output must be reduced by 10% for motors utilized in accordance with temperature class B.
- For information about SINAMICS G150 design variant A and "overload capability", refer to Catalog D 11, Part 3 and section "Configuration".
- Converter model 6SL3710-1GE38-4AA0 (840 A) must be selected when this drive is operated under high overload conditions!
- Converter model 6SL3710-1GF35-8AA0 (575 A) must be selected when this drive is operated under high overload conditions!
- Converter model 6SL3710-1GF38-1AA0 (810 A) must be selected when this drive is operated under high overload conditions!

#### Ordering example:

Low-voltage motor  
N-compact Standardline basic version  
3AC 400 V, 50 Hz, 1500 rpm, 4-pole, 355 kW  
with motor option K45: Anti-condensation heating for 230 V

Matching converter  
SINAMICS G150 variant A  
with converter option K50: Sensor Module Cabinet-Mounted for motor speed acquisition

**1LA8353-4PB80-Z  
+B20+K45**

**6SL3710-1GE37-5AA0-Z  
+K50**

### Options

N-compact Standardline motor		Relevant option with SINAMICS G150	
Option description	Order code	Option description	Order code
Motor temperature sensing using built-in temperature sensor KTY 84-130	A23	Standard	-
Motor temperature sensing by means of 6 built-in PT100 G resistance thermometers	A61	PT100 evaluation unit for 6 sensors, divided into two groups with factory setting, e.g. with motors, 3 PT100 for the stator windings and two for the motor bearings	L86
Installation of 2 screw-in PT100 resistance thermometers in basic circuit for rolling-contact bearings	A72		
Built-on pulse encoder LL861 900 220	H70	Sensor Module Cabinet-Mounted for motor speed acquisition	K50
Built-on pulse encoder HOG 10 D 1024 I For further options, see page 2/3.	H73		

# Low-Voltage Motors N-compact Standardline

## Operation with converter

Further converter options  
(see Catalog D 11 for detailed descriptions):

Option description	Order code
<b>Input side</b>	
Line filter for use in the first environment to EN 61 800-3, category C2 (TN/TT supplies)	L00
Main contactor for currents < 800 A	L13
Without line reactor in power range P < 500 kW	L22
Line reactor 2% may be required for P > 500 kW	L23
EMC shield bus <sup>1)</sup> (cable connection from below)	M70
PE bus <sup>1)</sup> (cable connection from below)	M75
<b>Output side</b>	
EMC shield bus <sup>1)</sup> (cable connection from below)	M70
PE bus <sup>1)</sup> (cable connection from below)	M75
<b>Motor protection and safety functions</b>	
EMERGENCY STOP button in the cabinet door	L45
EMERGENCY STOP category 0, 230 V AC or 24 V DC, uncontrolled stop	L57
EMERGENCY STOP category 1, 230 V AC, controlled stop <sup>2)</sup>	L59
EMERGENCY STOP category 1, 24 V DC, controlled stop <sup>2)</sup>	L60
Thermistor protection unit with PTB approval (alarm)	L83
Thermistor protection unit with PTB approval (switch-off)	L84
Insulation monitoring	L87
Additional shock protection	M60
<b>Increase in degree of protection</b>	
IP21 degree of protection	M21
IP23 degree of protection	M23
IP54 degree of protection	M54
<b>Mechanical options</b>	
Plinth, 100 mm high, RAL 7022	M06
Cable connection area, 200 mm high, RAL 7035	M07
Power supply connection from above	M13
Motor connection from above	M78
Top-mounted crane transport assembly for cabinets	M90
<b>Miscellaneous options</b>	
Customer terminal block extension	G61
Cabinet illumination with service socket	L50
Anti-condensation heating for cabinet	L55
200 kW braking unit	L62
<b>Languages</b>	
Documentation in English/French	D58
Documentation in English/Spanish	D60
Documentation in English/Italian	D80
Rating plate and operator panel in English/French	T58
Rating plate and operator panel in English/Spanish	T60
Rating plate and operator panel in English/Italian	T80
<b>Options specific to chemical industry</b>	
NAMUR terminal block	B00
Protective separation for 24 V supply (PELV)	B02
Separate output for external auxiliaries (uncontrolled)	B03

<sup>1)</sup> These options are listed for the input and output options, but are only required once.

<sup>2)</sup> The drive stop requirements must be taken into account with this option. Additional braking units may be needed.

### Dimensional drawings

#### SINAMICS G150 Converter Cabinet Units - Variant A

#### 6SL3710-1GE35-0AA0

Mains supply and motor terminals at bottom of cabinet (see Catalog D 11 for further connection options)

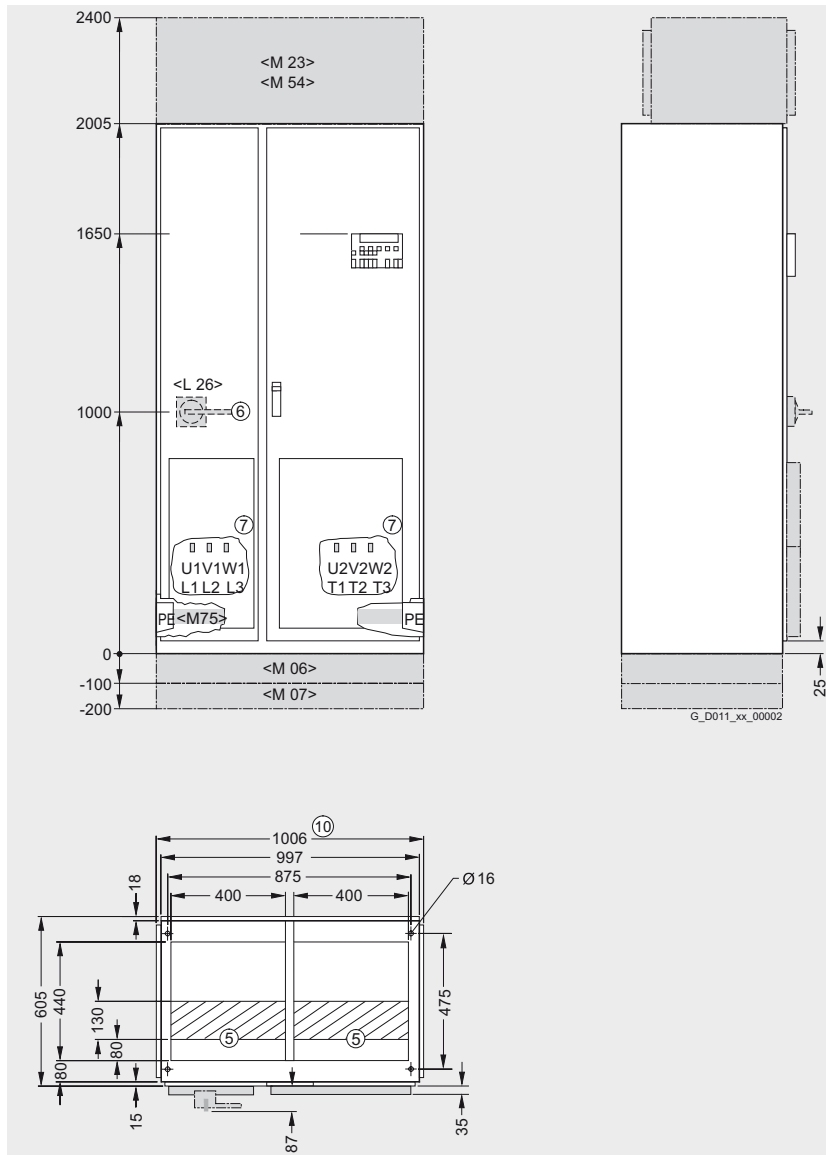

- ① Minimum ceiling height for wall mounting
  - ② Ventilation grille
  - ③ Air outlet zone
  - ④ Air inlet zone
  - ⑤ Cables can enter from below within hatched area
  - ⑥ Main switch, can be secured by padlock
  - ⑦ Power connection
  - ⑧ Degrees of protection option
  - ⑨ Degrees of protection IP20  
IP21 option <M21>  
IP23 option <M23>  
IP54 option <M54>
  - ⑩ Transport unit
- Options are shaded grey

### Degrees of protection

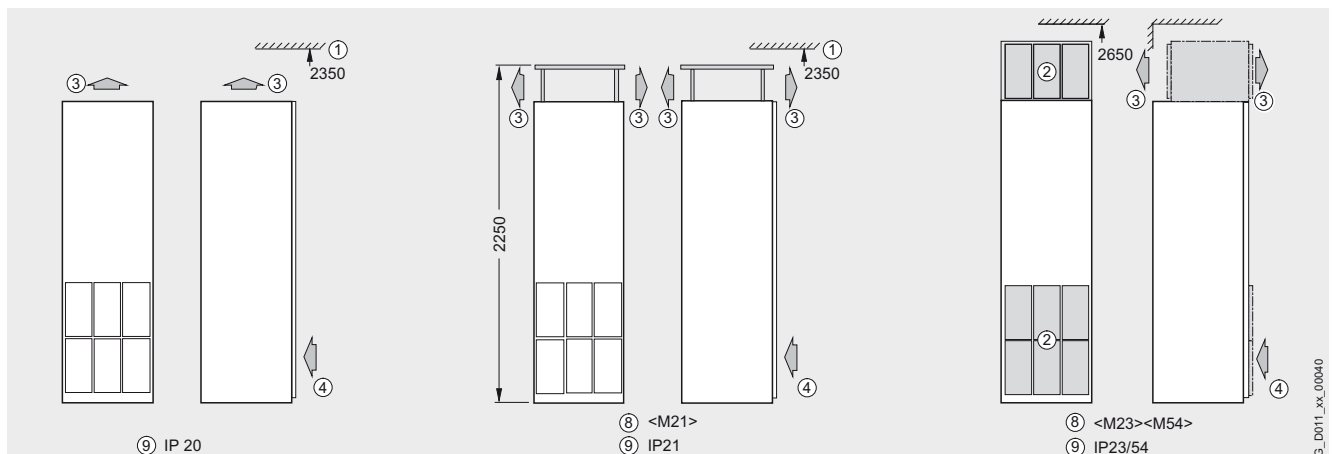

# Low-Voltage Motors N-compact Standardline

## Operation with converter

### Dimensional drawings

6SL3710-1GE36-1AA0, 6SL3710-1GF34-1AA0,  
6SL3710-1GF34-7AA0, 6SL3710-1GF35-8AA0

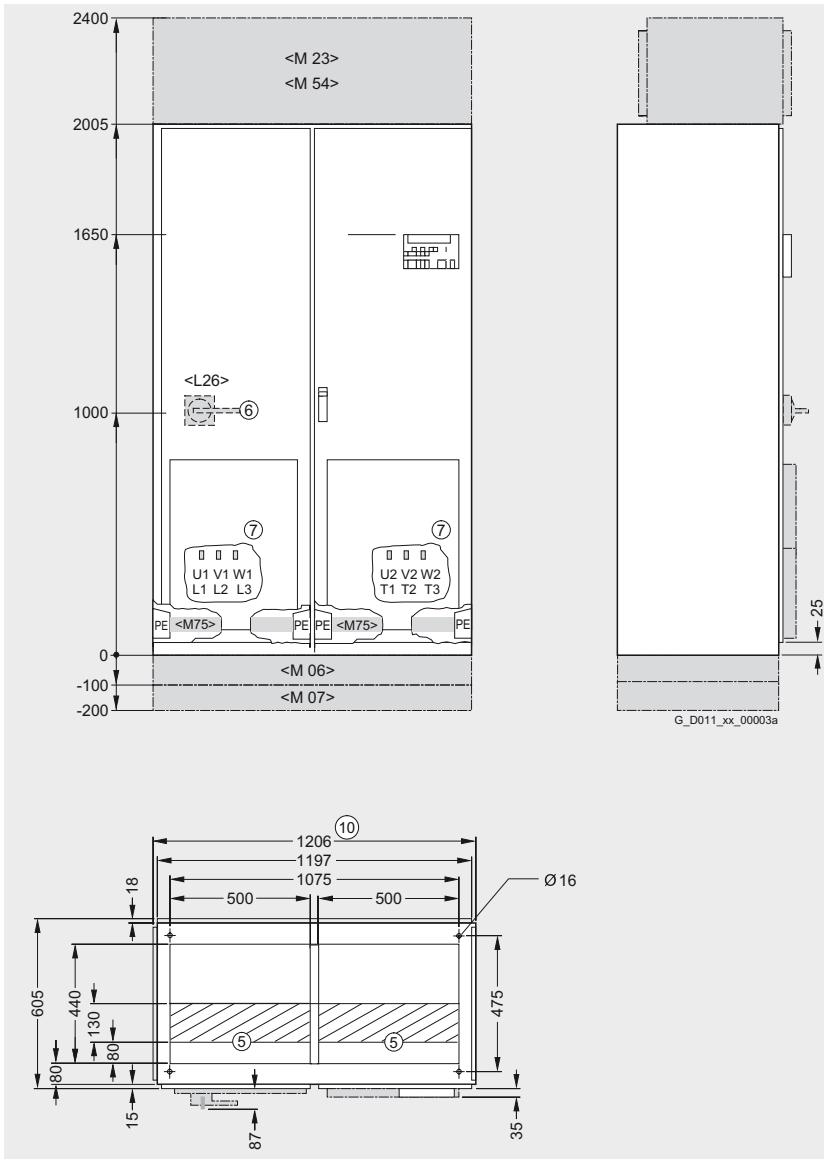

- ① Minimum ceiling height for wall mounting
- ② Ventilation grille
- ③ Air outlet zone
- ④ Air inlet zone
- ⑤ Cables can enter from below within hatched area
- ⑥ Main switch, can be secured by padlock
- ⑦ Power connection
- ⑧ Degrees of protection option
- ⑨ Degrees of protection IP20  
IP21 option <M21>  
IP23 option <M23>  
IP54 option <M54>

⑩ Transport unit  
Options are shaded grey

3

### Degrees of protection

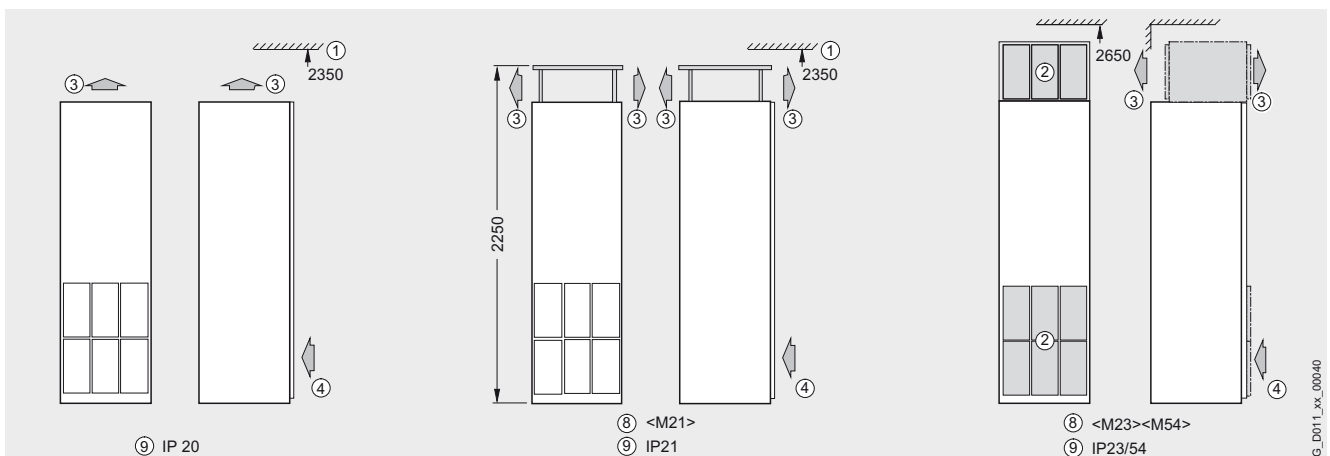

G\_D011\_xx\_00040

### Dimensional drawings

6SL3710-1GE37-5AA0, 6SL3710-1GE38-4AA0

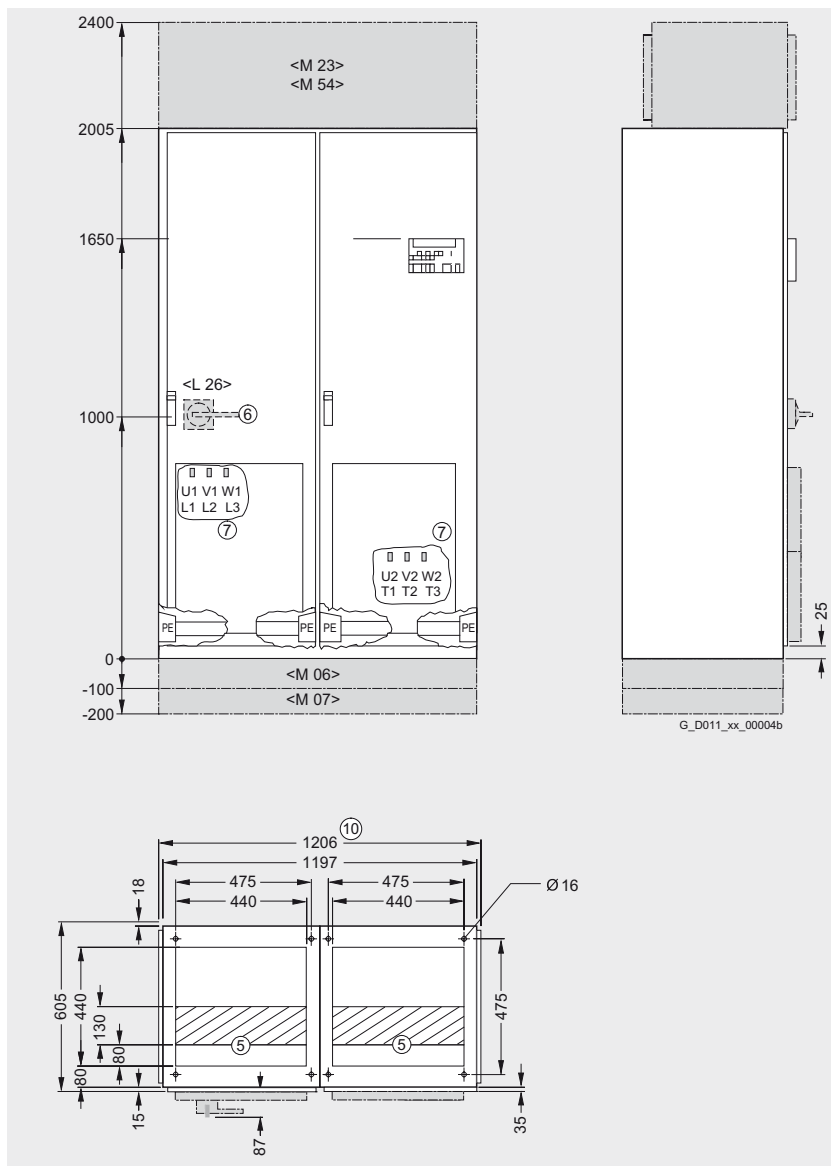

- ① Minimum ceiling height for wall mounting
  - ② Ventilation grille
  - ③ Air outlet zone
  - ④ Air inlet zone
  - ⑤ Cables can enter from below within hatched area
  - ⑥ Main switch, can be secured by padlock
  - ⑦ Power connection
  - ⑧ Degrees of protection option
  - ⑨ Degrees of protection IP20  
IP21 option <M21>  
IP23 option <M23>  
IP54 option <M54>
  - ⑩ Transport unit
- Options are shaded grey

3

### Degrees of protection

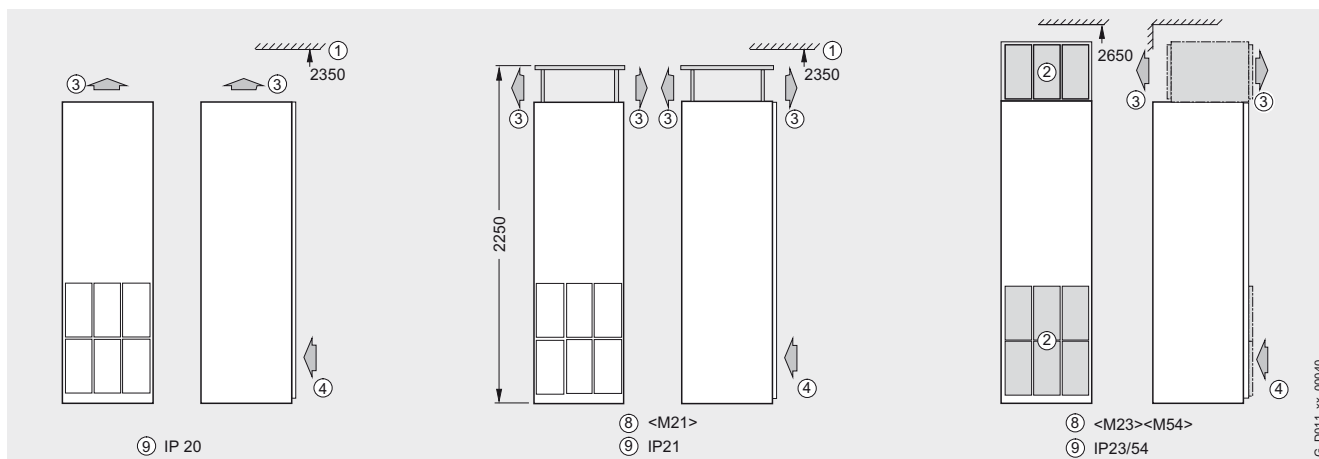

# Low-Voltage Motors N-compact Standardline

## Operation with converter

### Dimensional drawings

6SL3710-1GE41-0AA0, 6SL3710-1GF37-4AA0,  
6SL3710-1GF38-1AA0

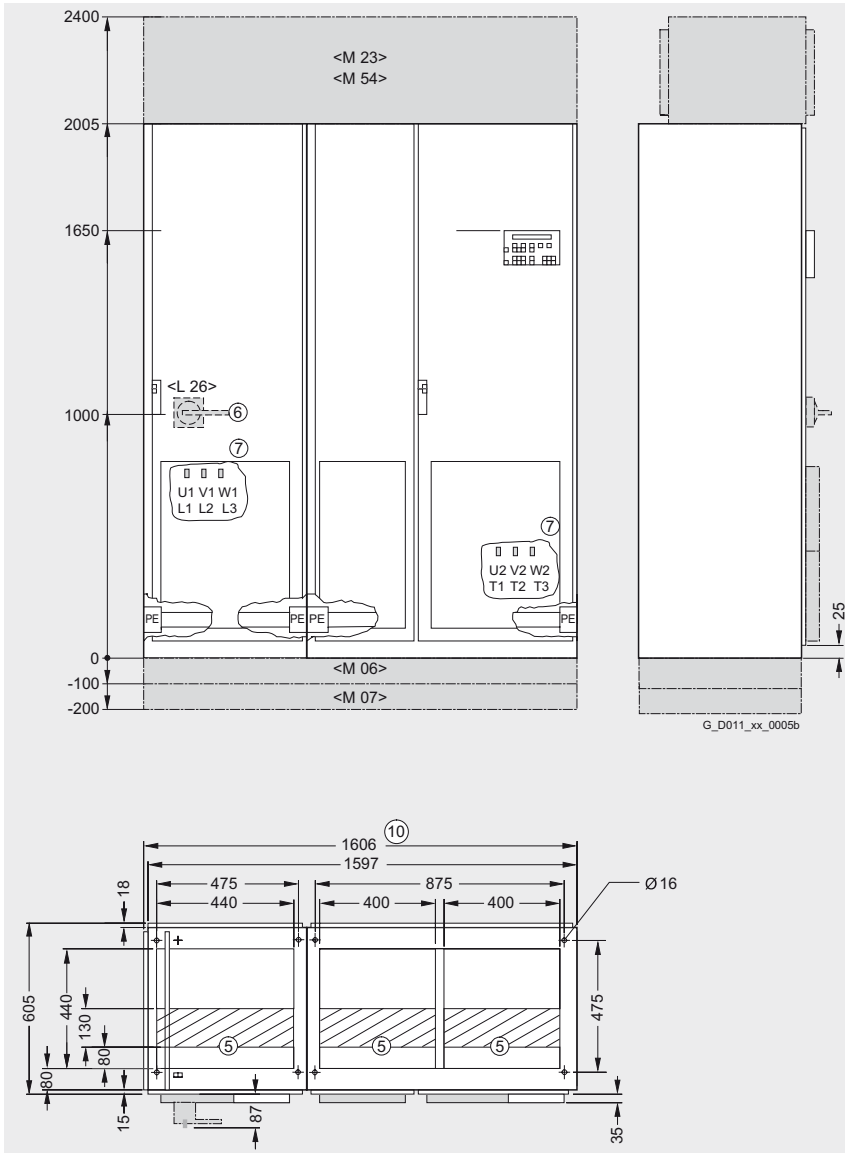

- ① Minimum ceiling height for wall mounting
- ② Ventilation grille
- ③ Air outlet zone
- ④ Air inlet zone
- ⑤ Cables can enter from below within hatched area
- ⑥ Main switch, can be secured by padlock
- ⑦ Power connection
- ⑧ Degrees of protection option
- ⑨ Degrees of protection IP20  
IP21 option <M21>  
IP23 option <M23>  
IP54 option <M54>

⑩ Transport unit  
Options are shaded grey

3

### Degrees of protection

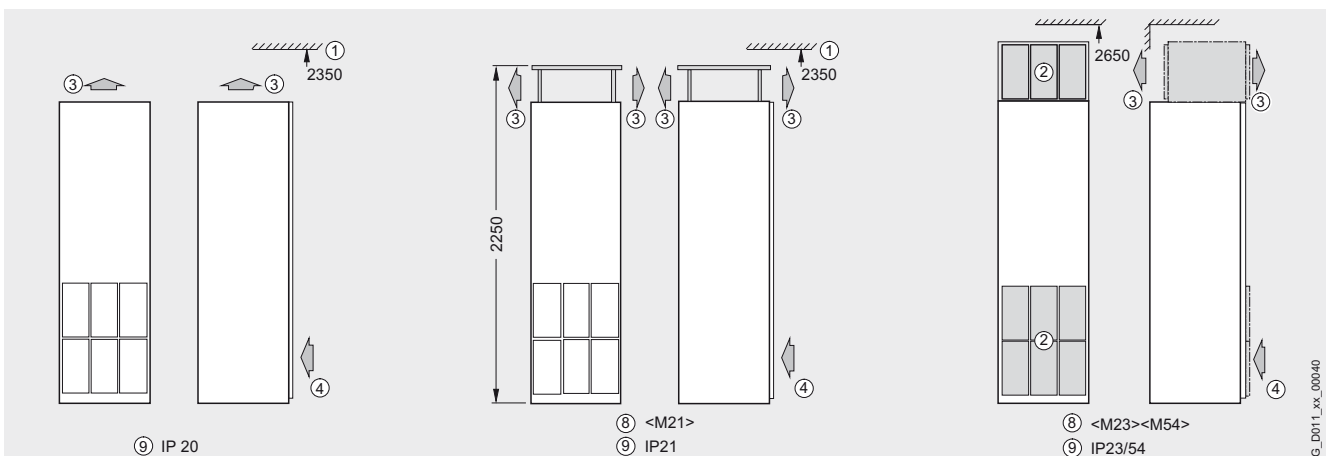

G\_D011\_xx\_00040

### More information

#### Power cables

The following table shows the recommended or maximum possible cable connections on the power supply and motor sides.

Drive power kW	Power supply connection (converter input)				Motor connection (converter output)				Motor connection box		
	Cable cross section (to DIN VDE)				Cable cross section (to DIN VDE)				Number of terminals	Contact screw thread	Max. diameter (sealing area connection box)
	Recommended	Max. cross section	Fixing screw M12 (no. of holes)		Recommended	Max. cross section	Fixing screw M12 (no. of holes)				
400 V mm <sup>2</sup>	500 V mm <sup>2</sup>	mm <sup>2</sup>		400 V mm <sup>2</sup>	500 V mm <sup>2</sup>	mm <sup>2</sup>				mm	
250	2 x 120	2 x 95	4 x 240	(2)	2 x 120	2 x 95	2 x 240	(2)	6	M12	41 ... 56.5
315	2 x 185	2 x 120	4 x 240	(2)	2 x 185	2 x 120	2 x 240	(2)	6	M12	41 ... 56.5
355	2 x 240	2 x 150	4 x 240	(2)	2 x 240	2 x 150	4 x 240	(2)	6	M16	56 ... 68.5
400	2 x 240	2 x 185	4 x 240	(2)	2 x 240	2 x 185	4 x 240	(2)	6	M16	56 ... 68.5
500	3 x 185	2 x 240	8 x 240	(4)	3 x 185	2 x 240	6 x 240	(3)	12	M16	56 ... 68.5

The cross section recommendations are based on the fuses specified in Part 3 "Accessories" of Catalog D11, and on single routing of 3-core copper cables at 40 °C ambient temperature.

If these conditions do not apply (cable routing, number of cables and ambient temperature), the planning guide for cable installation in Part 4 "Conductor cross sections and terminals" in Catalog D11 must be observed.

# Low-Voltage Motors N-compact Standardline

Notes

3



# High-Voltage Motors H-compact **Standardline** Operation on supply system

# 4



<b>4/2</b>	<b>Overview</b>
<b>4/2</b>	<b>Benefits</b>
<b>4/2</b>	<b>Technical specifications</b>
<b>4/3</b>	<b>Selection and Ordering Data</b>
<b>4/7</b>	<b>Options</b>
<b>4/8</b>	<b>Dimensional drawings</b>
<b>4/9</b>	<b>More information</b>
4/9	Description - construction details
4/9	Housing, cooling system
4/9	Hoisting gear
4/9	Rotor construction
4/9	Shaft
4/9	Direction of rotation, fans and fan shroud
4/9	Vibration response
4/9	Insulation system
4/9	Noise
4/9	Switching frequency
4/10	Connection box
4/10	Auxiliary connection box
4/10	Paint finish
4/10	Bearing construction



# High-Voltage Motors H-compact Standardline

## Operation on supply system

### Overview



H-compact Standardline is a range of standardized, rib-cooled high-voltage motors incorporating the latest state-of-the-art technology.

Their appeal lies in their excellent reliability, durability and robust design.

The following versions of H-compact Standardline motors are available:

- Power range 200 to 800 kW
- Supply voltages 3 / 3.3 / 6 and 6.6 kV, 50 Hz
- 2-pole, 4-pole and 6-pole
- Type of construction IM B3

### Benefits

The focus on a design which is standardized, but capable of satisfying a wide range of applications, has made it possible to optimize production processes and consequently slash delivery times and the price at which high-voltage motors are supplied.

Benefits to the customer:

- State-of-the-art motor technology which is already in use worldwide
- Attractive price
- Quick delivery time of only 6 weeks
- Maximum power density
- Low operating costs thanks to excellent efficiency
- High output combined with small dimensions makes it possible to build extremely compact units

### Technical specifications

Type of construction	IM B3 (IM 1001)
Shaft heights	315 mm, 355 mm, 400 mm
Type of protection	IP55
Cooling method	IC 411; ribbed cooling, self-ventilated, with additional inner cooling circuit
Ambient conditions	Max. ambient temperature (cooling medium temp.) CT = 40 °C Installation altitude ≤1000 m above sea level. Ambient temperatures up to 55 °C possible with utilization according to temperature class F. Operation and starting permissible at temperatures down to -20 °C.
Insulation system	MICALASTIC® with Vacuum Pressure Impregnation (VPI)
Rotor construction	with aluminum die-cast cage
Bearing construction	Deep-groove ball bearing to DIN 625, with SPM nipple (shock pulse measurement)
Bearing box and shields	Made of grey cast iron, integrally cast motor feet
Temperature monitoring	By 6 PT 100s in stator winding as standard (not included if PTC thermistors are ordered)
Auxiliary connection box	standard feature
Regulations and standards	in accordance with IEC 60034-1 ff.

### Selection and Ordering Data

Note:

Motors are available only with the specified data for voltage, frequency and output.

The documentation supplied is standardized. It contains starting characteristics for  $V_{rated}$  and 80 %  $V_{rated}$  without load torque. A starting inspection is not included.

Rated output 1)	Order No. + order codes for further options	Operating values at rated output						Starting torque	Starting current	Stalling torque	Moment of inertia J		Sound pressure level 2)			
		Rated speed	Efficiency $\eta$ with		Power factor $\cos \varphi$	Rated current	Rated torque				with direct starting as multiple of rated			Motor	External max. perm.	
			4/4 load	3/4 load							torque	current				torque
kW		rpm	%	%	A	Nm							dB(A)			
<b>3 kV, 50 Hz</b>																
<b>3000 rpm, 2-pole</b>																
200	1LA4310-2AN30-Z + B20	2970	95.2	95.2	0.87	46.0	643	0.90	5.05	2.3	2.2	28	73/74			
236	1LA4312-2AN30-Z + B20	2967	95.0	95.2	0.87	55.0	759	0.90	5.00	2.3	2.2	26	73/74			
300	1LA4314-2AN30-Z + B20	2972	95.7	95.8	0.88	69.0	964	1.05	5.20	2.4	2.7	30	73/74			
355	1LA4316-2AN30-Z + B20	2974	96.2	96.2	0.88	81.0	1140	1.10	5.30	2.5	3.1	35	73/74			
400	1LA4350-2AN30-Z + B20	2978	96.1	96.2	0.88	91.0	1283	1.05	5.25	2.3	4.3	38	75/76			
450	1LA4352-2AN30-Z + B20	2978	96.4	96.4	0.88	102.0	1443	1.20	5.55	2.5	4.8	43	75/76			
500	1LA4354-2AN30-Z + B20	2980	96.6	96.7	0.88	114.0	1602	1.20	5.55	2.5	5.2	46	75/76			
560	1LA4400-2AN30-Z + B20	2984	96.5	96.4	0.88	128.0	1792	0.85	5.40	2.5	7.8	26	77/78			
650	1LA4402-2AN30-Z + B20	2985	96.8	96.7	0.88	146.0	2079	0.90	5.60	2.6	8.7	27	77/78			
750	1LA4404-2AN30-Z + B20	2985	96.7	96.7	0.89	168.5	2398	0.95	5.60	2.6	9.9	30	77/78			
<b>1500 rpm, 4-pole</b>																
200	1LA4310-4AN30-Z + B20	1480	94.3	94.4	0.81	50.0	1290	1.15	5.20	2.30	2.8	159	75/77			
250	1LA4312-4AN30-Z + B20	1480	95.0	95.2	0.84	60.0	1613	1.15	5.30	2.30	3.5	201	75/77			
300	1LA4314-4AN30-Z + B20	1480	95.2	95.4	0.85	72.0	1936	1.25	5.50	2.40	4.0	222	75/77			
365	1LA4316-4AN30-Z + B20	1481	95.7	95.9	0.85	87.0	2353	1.25	5.50	2.40	4.8	297	75/77			
400	1LA4350-4AN30-Z + B20	1485	95.7	95.8	0.84	96.0	2572	1.25	5.50	2.50	6.0	224	77/79			
470	1LA4352-4AN30-Z + B20	1484	95.9	96.0	0.85	110.0	3024	1.20	5.30	2.35	6.9	247	77/79			
560	1LA4354-4AN30-Z + B20	1485	96.2	96.3	0.86	130.0	3601	1.30	5.50	2.40	8.1	296	77/79			
630	1LA4400-4AN30-Z + B20	1488	96.3	96.3	0.85	148.0	4043	1.20	5.50	2.50	11.6	288	79/81			
710	1LA4402-4AN30-Z + B20	1488	96.5	96.5	0.85	166.0	4556	1.20	5.50	2.50	12.9	330	79/81			
800	1LA4404-4AN30-Z + B20	1488	96.6	96.6	0.86	186.0	5134	1.20	5.50	2.50	14.5	381	79/81			
<b>1000 rpm, 6-pole</b>																
236	1LA4314-6AN30-Z + B20	986	94.6	94.9	0.82	59.0	2286	1.25	5.30	2.50	5.3	375	69/72			
270	1LA4316-6AN30-Z + B20	985	94.8	95.2	0.82	66.0	2617	1.25	5.50	2.40	6.4	431	69/72			
315	1LA4350-6AN30-Z + B20	989	95.3	95.5	0.82	78.0	3042	1.10	5.30	2.30	10.8	541	71/74			
365	1LA4352-6AN30-Z + B20	989	95.6	95.8	0.83	89.0	3523	1.10	5.30	2.20	12.7	667	71/74			
425	1LA4354-6AN30-Z + B20	990	95.8	95.9	0.82	104.0	4099	1.25	5.50	2.40	15.0	841	71/74			
490	1LA4400-6AN30-Z + B20	991	95.9	96.0	0.81	118.0	4722	1.05	5.50	2.30	21.2	740	73/76			
570	1LA4402-6AN30-Z + B20	992	96.2	96.3	0.81	136.0	5487	1.10	5.50	2.30	24.2	1193	73/76			
630	1LA4404-6AN30-Z + B20	991	96.3	96.3	0.80	154.0	6071	1.20	5.50	2.40	27.3	1233	73/76			

1) Temperature class F, utilization in accordance with B.

2) Measured at distance of 1 m in accordance with DIN 45635 (Part 1), tolerance +3 dB(A).

# High-Voltage Motors H-compact Standardline

## Operation on supply system

Rated output 1)  kW	Order No. + order codes for further options	Operating values at rated output						Starting torque with direct starting as multiple of rated torque	Starting current of rated current	Stalling torque	Moment of inertia J		Sound pressure level 2)  dB(A)	
		Rated speed  rpm	Efficiency $\eta$ with		Power factor  $\cos \varphi$	Rated current  A	Rated torque  Nm				Motor  kgm <sup>2</sup>	External max. perm.  kgm <sup>2</sup>		No load/ load
			4/4 load %	3/4 load %										
<b>3.3 kV, 50 Hz</b>														
<b>3000 rpm, 2-pole</b>														
200	1LA4310-2AN00-Z + B20	2977	95.5	95.2	0.85	43.0	641	1.10	6.00	2.85	2.2	28	73/74	
236	1LA4312-2AN00-Z + B20	2975	95.2	95.2	0.84	52.0	757	1.10	5.90	2.80	2.2	26	73/74	
300	1LA4314-2AN00-Z + B20	2978	95.9	95.7	0.85	65.0	962	1.30	6.15	2.95	2.7	30	73/74	
355	1LA4316-2AN00-Z + B20	2980	96.3	96.1	0.85	76.0	1138	1.35	6.30	3.10	3.1	35	73/74	
400	1LA4350-2AN00-Z + B20	2983	96.3	96.2	0.85	86.0	1280	1.30	6.15	2.85	4.3	38	75/76	
450	1LA4352-2AN00-Z + B20	2983	96.5	96.4	0.85	96.5	1441	1.45	6.50	3.10	4.8	43	75/76	
500	1LA4354-2AN00-Z + B20	2985	96.7	96.7	0.85	107.0	1600	1.45	6.55	3.10	5.2	46	75/76	
560	1LA4400-2AN00-Z + B20	2988	96.6	96.3	0.84	121.5	1790	1.05	6.35	3.05	7.8	26	77/78	
650	1LA4402-2AN00-Z + B20	2988	96.8	96.6	0.85	138.0	2077	1.10	6.60	3.20	8.7	27	77/78	
750	1LA4404-2AN00-Z + B20	2989	96.8	96.6	0.87	157.0	2396	1.15	6.70	3.20	9.9	30	77/78	
<b>1500 rpm, 4-pole</b>														
200	1LA4310-4AN00-Z + B20	1484	94.4	94.2	0.74	50.0	1287	1.40	5.75	2.80	2.8	159	75/77	
250	1LA4312-4AN00-Z + B20	1485	95.2	95.2	0.79	58.0	1608	1.40	6.15	2.85	3.5	201	75/77	
300	1LA4314-4AN00-Z + B20	1484	95.4	95.4	0.80	69.5	1931	1.55	6.35	2.95	4.0	222	75/77	
365	1LA4316-4AN00-Z + B20	1485	95.9	95.9	0.80	83.5	2346	1.55	6.35	2.95	4.8	297	75/77	
400	1LA4350-4AN00-Z + B20	1488	95.8	95.6	0.77	95.0	2566	1.55	6.20	3.05	6.0	224	77/79	
470	1LA4352-4AN00-Z + B20	1488	96.1	96.0	0.80	105.5	3017	1.45	6.15	2.85	6.9	247	77/79	
560	1LA4354-4AN00-Z + B20	1489	96.4	96.3	0.82	124.0	3592	1.60	6.40	2.95	8.1	296	77/79	
630	1LA4400-4AN00-Z + B20	1491	96.4	96.2	0.80	143.0	4036	1.45	6.35	3.05	11.6	288	79/81	
710	1LA4402-4AN00-Z + B20	1491	96.6	96.4	0.81	159.0	4548	1.45	6.40	3.05	12.9	330	79/81	
800	1LA4404-4AN00-Z + B20	1491	96.7	96.5	0.82	177.5	5125	1.45	6.45	3.05	14.5	381	79/81	
<b>1000 rpm, 6-pole</b>														
236	1LA4314-6AN00-Z + B20	989	94.8	94.8	0.77	57.0	2279	1.50	6.10	3.05	5.3	375	69/72	
270	1LA4316-6AN00-Z + B20	988	95.1	95.2	0.78	62.5	2609	1.55	6.45	2.95	6.4	431	69/72	
315	1LA4350-6AN00-Z + B20	991	95.5	95.4	0.78	74.5	3034	1.35	6.20	2.80	10.8	541	71/74	
365	1LA4352-6AN00-Z + B20	991	95.8	95.7	0.79	84.5	3515	1.35	6.20	2.70	12.7	667	71/74	
425	1LA4354-6AN00-Z + B20	992	95.9	95.8	0.78	99.5	4091	1.55	6.40	2.95	15.0	841	71/74	
490	1LA4400-6AN00-Z + B20	993	96.0	95.9	0.81	111.5	4713	1.30	6.50	2.80	21.2	740	73/76	
570	1LA4402-6AN00-Z + B20	994	96.3	96.2	0.81	128.5	5476	1.35	6.45	2.80	24.2	1193	73/76	
630	1LA4404-6AN00-Z + B20	993	96.4	96.2	0.78	146.5	6060	1.45	6.45	2.95	27.3	1233	73/76	

1) Temperature class F, utilization in accordance with B.

2) Measured at distance of 1 m in accordance with DIN 45635 (Part 1), tolerance +3 dB(A).

# High-Voltage Motors H-compact Standardline

## Operation on supply system

Rated output 1)	Order No. + order codes for further options	Operating values at rated output						Starting torque	Starting current	Stalling torque	Moment of inertia J		Sound pressure level 2)			
		Rated speed	Efficiency $\eta$ with		Power factor $\cos \varphi$	Rated current	Rated torque				with direct starting as multiple of rated			Motor	External max. perm.	
			4/4 load	3/4 load							torque	current				torque
kW		rpm	%	%	A	Nm							dB(A)			
<b>6 kV, 50 Hz</b>																
<b>3000 rpm, 2-pole</b>																
200	1LA4310-2AN60-Z + B20	2970	95.2	95.2	0.87	23.0	643	0.90	5.00	2.30	2.2	28	73/74			
236	1LA4312-2AN60-Z + B20	2967	95.0	95.2	0.87	27.5	759	0.90	5.00	2.30	2.2	26	73/74			
300	1LA4314-2AN60-Z + B20	2972	95.7	95.8	0.88	34.5	964	1.05	5.20	2.40	2.7	30	73/74			
355	1LA4316-2AN60-Z + B20	2974	96.2	96.2	0.88	40.5	1140	1.10	5.30	2.50	3.1	35	73/74			
400	1LA4350-2AN60-Z + B20	2978	96.1	96.2	0.88	45.5	1283	1.05	5.20	2.30	4.3	38	75/76			
450	1LA4352-2AN60-Z + B20	2978	96.4	96.4	0.88	51.0	1443	1.20	5.50	2.50	4.8	43	75/76			
500	1LA4354-2AN60-Z + B20	2980	96.6	96.7	0.88	57.0	1602	1.20	5.50	2.50	5.2	46	75/76			
560	1LA4400-2AN60-Z + B20	2984	96.5	96.4	0.88	64.0	1792	0.85	5.40	2.50	7.8	26	77/78			
650	1LA4402-2AN60-Z + B20	2985	96.8	96.7	0.88	73.0	2079	0.90	5.60	2.60	8.7	27	77/78			
750	1LA4404-2AN60-Z + B20	2985	97.0	96.9	0.89	84.0	2399	0.95	5.60	2.60	9.9	30	77/78			
<b>1500 rpm, 4-pole</b>																
200	1LA4310-4AN60-Z + B20	1480	94.3	94.4	0.81	25.0	1290	1.15	5.20	2.30	2.8	159	75/77			
250	1LA4312-4AN60-Z + B20	1480	95.0	95.2	0.84	30.0	1613	1.15	5.30	2.30	3.5	201	75/77			
300	1LA4314-4AN60-Z + B20	1480	95.2	95.4	0.85	36.0	1936	1.25	5.50	2.40	4.0	222	75/77			
365	1LA4316-4AN60-Z + B20	1481	95.7	95.9	0.85	43.5	2353	1.25	5.50	2.40	4.8	297	75/77			
400	1LA4350-4AN60-Z + B20	1485	95.7	95.8	0.84	48.0	2572	1.25	5.50	2.50	6.0	224	77/79			
470	1LA4352-4AN60-Z + B20	1484	95.9	96.0	0.85	55.0	3024	1.20	5.30	2.35	6.9	247	77/79			
560	1LA4354-4AN60-Z + B20	1485	96.2	96.3	0.86	65.0	3601	1.30	5.50	2.40	8.1	296	77/79			
630	1LA4400-4AN60-Z + B20	1488	96.3	96.3	0.85	74.0	4043	1.20	5.50	2.50	11.6	288	79/81			
710	1LA4402-4AN60-Z + B20	1488	96.5	96.5	0.85	83.0	4556	1.20	5.50	2.50	12.9	330	79/81			
800	1LA4404-4AN60-Z + B20	1488	96.6	96.6	0.86	93.0	5134	1.20	5.50	2.50	14.5	381	79/81			
<b>1000 rpm, 6-pole</b>																
236	1LA4314-6AN60-Z + B20	986	94.6	94.9	0.82	29.5	2286	1.25	5.30	2.50	5.3	375	69/72			
270	1LA4316-6AN60-Z + B20	985	94.8	95.2	0.82	33.0	2617	1.25	5.50	2.40	6.4	431	69/72			
315	1LA4350-6AN60-Z + B20	989	95.3	95.5	0.82	39.0	3041	1.10	5.30	2.30	10.8	541	71/74			
365	1LA4352-6AN60-Z + B20	989	95.6	95.8	0.83	44.5	3524	1.10	5.30	2.20	12.7	667	71/74			
425	1LA4354-6AN60-Z + B20	990	95.8	95.9	0.82	52.0	4099	1.25	5.50	2.40	15.0	841	71/74			
490	1LA4400-6AN60-Z + B20	991	95.9	96.0	0.84	59.0	4722	1.05	5.50	2.30	21.2	740	73/76			
570	1LA4402-6AN60-Z + B20	992	96.2	96.3	0.84	68.0	5487	1.10	5.50	2.30	24.2	1193	73/76			
630	1LA4404-6AN60-Z + B20	991	96.3	96.3	0.82	77.0	6071	1.20	5.50	2.40	27.3	1233	73/76			

1) Temperature class F, utilization in accordance with B.

2) Measured at distance of 1 m in accordance with DIN 45635 (Part 1), tolerance +3 dB(A).

# High-Voltage Motors H-compact Standardline

## Operation on supply system

Rated output 1)	Order No. + order codes for further options	Operating values at rated output						Starting torque	Starting current	Stalling torque	Moment of inertia J		Sound pressure level 2)			
		Rated speed	Efficiency $\eta$ with		Power factor $\cos \varphi$	Rated current	Rated torque				with direct starting as multiple of rated			Motor	External max. perm.	
			4/4 load	3/4 load							torque	current				torque
kW		rpm	%	%	A	Nm							dB(A)			
<b>6.6 kV, 50 Hz</b>																
<b>3000 rpm, 2-pole</b>																
200	1LA4310-2AN70-Z + B20	2977	95.4	95.2	0.85	21.5	641	1.10	6.00	2.80	2.2	28	73/74			
236	1LA4312-2AN70-Z + B20	2975	95.2	95.2	0.84	26.0	757	1.10	5.90	2.80	2.2	26	73/74			
300	1LA4314-2AN70-Z + B20	2978	95.9	95.7	0.85	32.5	962	1.30	6.15	2.95	2.7	30	73/74			
355	1LA4316-2AN70-Z + B20	2980	96.3	96.1	0.85	38.0	1138	1.35	6.30	3.05	3.1	35	73/74			
400	1LA4350-2AN70-Z + B20	2983	96.3	96.2	0.85	43.0	1280	1.30	6.10	2.80	4.3	38	75/76			
450	1LA4352-2AN70-Z + B20	2983	96.5	96.3	0.85	48.0	1441	1.45	6.50	3.05	4.8	43	75/76			
500	1LA4354-2AN70-Z + B20	2985	96.7	96.7	0.85	53.5	1600	1.45	6.50	3.05	5.2	46	75/76			
560	1LA4400-2AN70-Z + B20	2988	96.5	96.3	0.84	60.5	1790	1.00	6.30	3.05	7.8	26	77/78			
650	1LA4402-2AN70-Z + B20	2988	96.8	96.6	0.85	69.0	2077	1.10	6.60	3.20	8.7	27	77/78			
750	1LA4404-2AN70-Z + B20	2989	97.1	96.8	0.87	78.5	2396	1.15	6.70	3.20	9.9	30	77/78			
<b>1500 rpm, 4-pole</b>																
200	1LA4 310-4AN70-Z + B20	1484	94.4	94.2	0.74	25.0	1287	1.40	5.75	2.80	2.8	159	75/77			
250	1LA4 312-4AN70-Z + B20	1485	95.2	95.2	0.79	29.0	1609	1.40	6.10	2.80	3.5	201	75/77			
300	1LA4 314-4AN70-Z + B20	1484	95.4	95.3	0.80	35.0	1931	1.55	6.30	2.95	4.0	222	75/77			
365	1LA4 316-4AN70-Z + B20	1485	95.9	95.9	0.80	42.0	2346	1.55	6.35	2.95	4.8	297	75/77			
400	1LA4 350-4AN70-Z + B20	1488	95.8	95.6	0.77	47.5	2567	1.50	6.20	3.05	6.0	224	77/79			
470	1LA4 352-4AN70-Z + B20	1488	96.1	96.0	0.80	53.0	3017	1.45	6.15	2.85	6.9	247	77/79			
560	1LA4 354-4AN70-Z + B20	1490	96.4	96.3	0.82	62.0	3592	1.55	6.40	2.95	8.1	296	77/79			
630	1LA4 400-4AN70-Z + B20	1491	96.4	96.2	0.80	71.5	4036	1.45	6.35	3.05	11.6	288	79/81			
710	1LA4 402-4AN70-Z + B20	1491	96.6	96.4	0.81	79.5	4548	1.45	6.40	3.05	12.9	330	79/81			
800	1LA4 404-4AN70-Z + B20	1491	96.7	96.5	0.82	88.5	5125	1.45	6.40	3.05	14.5	381	79/81			
<b>1000 rpm, 6-pole</b>																
236	1LA4 314-6AN70-Z + B20	989	94.8	94.8	0.77	28.5	2279	1.50	6.10	3.05	5.3	375	69/72			
270	1LA4 316-6AN70-Z + B20	988	95.1	95.2	0.78	31.5	2609	1.55	6.45	2.95	6.4	431	69/72			
315	1LA4 350-6AN70-Z + B20	991	95.5	95.4	0.78	37.0	3034	1.35	6.15	2.80	10.8	541	71/74			
365	1LA4 352-6AN70-Z + B20	991	95.8	95.7	0.79	42.0	3515	1.35	6.20	2.70	12.7	667	71/74			
425	1LA4 354-6AN70-Z + B20	992	95.9	95.8	0.78	50.0	4091	1.55	6.40	2.95	15.0	841	71/74			
490	1LA4 400-6AN70-Z + B20	993	96.0	95.9	0.81	55.5	4713	1.30	6.45	2.80	21.2	740	73/76			
570	1LA4 402-6AN70-Z + B20	994	96.3	96.2	0.81	64.5	5476	1.35	6.45	2.80	24.2	1193	73/76			
630	1LA4 404-6AN70-Z + B20	993	96.4	96.2	0.78	73.0	6060	1.45	6.45	2.95	27.3	1233	73/76			

1) Temperature class F, utilization in accordance with B.

2) Measured at distance of 1 m in accordance with DIN 45635 (Part 1), tolerance +3 dB(A).

### Ordering example:

High-voltage motor  
H-compact Standardline basic version  
6.6 kV, 50 Hz, 1500 rpm, 4-pole, 300 kW  
with option M13: Anti-condensation heating for 230 V

**1LA4314-4AN70-Z  
+B20+M13**

### Options

Option description	Order code	Comment
Standardline design	<b>B20</b>	Always state
Motor protection through PTC thermistor with 6 built-in temperature sensors for alarm and switch-off	<b>A12</b>	
Motor temperature sensing by means of 6 built-in PT100 G resistance thermometers	<b>A65</b>	Standard
Installation of 2 screw-in PT100 resistance thermometers in basic circuit for rolling-contact bearings	<b>A40</b>	
Nipples for SPM (shock pulse measurement)	<b>G50</b>	Standard
Connection box on RHS (view onto DE)	<b>K09</b>	
Connection box on LHS (view onto DE)	<b>K10</b>	
Connection box at 90° angle, cable from DE	<b>K83</b>	
Connection box at 90° angle, cable from NDE	<b>K84</b>	
Connection box at 180° angle, cable from top	<b>K85</b>	
Special finish in standard color RAL 7030	<b>K26</b>	
Anti-condensation heating for 110 V	<b>M12</b>	
Anti-condensation heating for 230 V	<b>M13</b>	
Supplementary (second) auxiliary connection box in grey cast iron	<b>M50</b>	
Separate auxiliary connection box for anti-condensation heating	<b>M52</b>	
Version for clockwise rotation	<b>K97</b>	
Version for counter-clockwise rotation	<b>K98</b>	
Ambient temperature 45 °C	<b>D11</b>	With utilization in accordance with F
Ambient temperature 50 °C	<b>D12</b>	With utilization in accordance with F
Ambient temperature 55 °C	<b>D13</b>	With utilization in accordance with F
Standard paint finish in a color different from RAL 7030	<b>Y53</b>	Plain text required
<b>Documentation</b>		
Documentation in English	-	Standard
Documentation in German	<b>D00</b>	
Documentation in Russian	<b>D56</b>	
Documentation in Italian	<b>D72</b>	
Documentation in French	<b>D77</b>	
Documentation in Spanish	<b>D78</b>	
Documentation in Portuguese	<b>D79</b>	
Documentation in Swedish	<b>D83</b>	
Documentation in Chinese	<b>D84</b>	
Documentation on CD-ROM	<b>B21</b>	

# High-Voltage Motors H-compact Standardline

## Operation on supply system

### Dimensional drawings

Design:

Type IM B3, rolling-contact bearing, degree of protection IP55,  
type of cooling IC 441

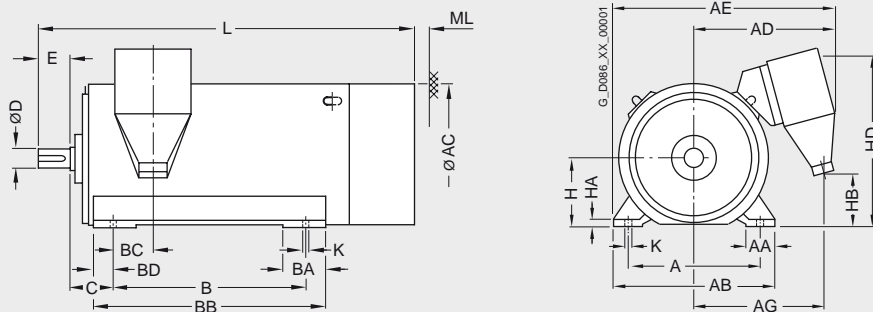

Type	Weight kg	A mm	AD mm	AE mm	B mm	C mm	H mm	HD mm	L mm	D mm	E mm
<b>2-pole</b>											
1LA4310-2	1550	610	710	1075	710	200	315	860	1590	70	105
1LA4312-2	1550	610	710	1075	710	200	315	860	1590	70	105
1LA4314-2	1850	610	710	1075	900	200	315	860	1790	70	105
1LA4316-2	2000	610	710	1075	900	200	315	860	1790	70	105
1LA4350-2	2300	686	740	1155	1000	224	355	930	1930	75	105
1LA4352-2	2400	686	740	1155	1000	224	355	930	1930	75	105
1LA4354-2	2550	686	740	1155	1000	224	355	930	1930	75	105
1LA4400-2	3150	750	775	1120	1120	254	400	1010	2095	85	130
1LA4402-2	3300	750	775	1120	1120	254	400	1010	2095	85	130
1LA4404-2	3550	750	775	1120	1120	254	400	1010	2095	85	130
<b>4-pole</b>											
1LA4310-4	1500	610	710	1075	710	200	315	860	1610	90	130
1LA4312-4	1650	610	710	1075	710	200	315	860	1610	90	130
1LA4314-4	1900	610	710	1075	900	200	315	860	1810	90	130
1LA4316-4	2050	610	710	1075	900	200	315	860	1810	90	130
1LA4350-4	2350	686	740	1155	1000	224	355	930	1985	100	165
1LA4352-4	2550	686	740	1155	1000	224	355	930	1985	100	165
1LA4354-4	2750	686	740	1155	1000	224	355	930	1985	100	165
1LA4400-4	3400	750	775	1125	1120	254	400	1010	2125	120	165
1LA4402-4	3600	750	775	1125	1120	254	400	1010	2125	120	165
1LA4404-4	3800	750	775	1125	1120	254	400	1010	2125	120	165
<b>6-pole</b>											
1LA4314-6	1950	610	710	1075	900	200	315	860	1810	90	130
1LA4316-6	2150	610	710	1075	900	200	315	860	1810	90	130
1LA4350-6	2400	686	740	1155	1000	224	355	930	1985	100	165
1LA4352-6	2600	686	740	1155	1000	224	355	930	1985	100	165
1LA4354-6	2850	686	740	1155	1000	224	355	930	1985	100	165
1LA4400-6	3500	750	775	1225	1120	254	400	1010	2125	120	165
1LA4402-6	3750	750	775	1225	1120	254	400	1010	2125	120	165
1LA4404-6	4000	750	775	1225	1120	254	400	1010	2125	120	165

### More information

#### Description - construction details

##### Housing, cooling system

The stator housing on all motors is made of grey cast iron.

The housing contains 4 axial cooling air ducts equally spaced around the circumference.

The main and auxiliary connection boxes are bolted onto the two upper ducts, which also contain the winding conductors and monitoring cables.

The two bottom ducts are located in the foot area.

These cooling air ducts are a component of the supplementary inner cooling circuit that is a feature of Siemens H-compact and N-compact motors. This cooling circuit ensures even thermal distribution within the motor and provides for optimum cooling. The resulting bearing and winding overhang temperatures have a positive impact on the service life and availability of the motors.

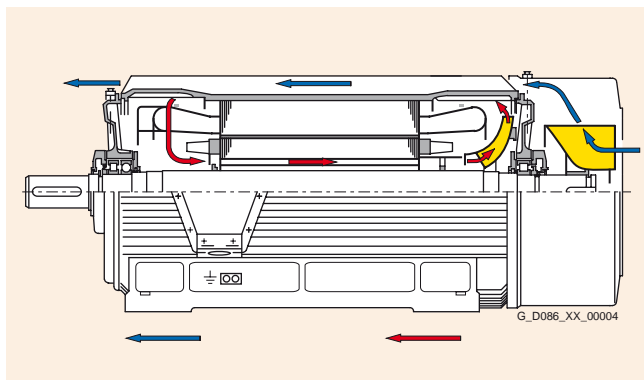

##### Hoisting gear

Two diagonally arranged, reversible hoisting lugs which align automatically with the lifting cable, i.e. according to the applied direction of force.

##### Rotor construction

The rotor winding is made of die-cast aluminum.

The aluminum is poured into the rotor slots under pressure and thus bonded with the rotor laminations in a positive connection. This method of manufacture precludes any risk of cage movement or cage "creepage" in the rotor core.

Another advantage of the die-cast method is the excellent thermal coupling between the cage and laminated rotor core, resulting in high permissible starting and rotor locking times.

##### Shaft

All motors have a shaft extension designed according to DIN 748 "short" with key steel featherkey according to DIN 6880. The rotors are balanced with half-key.

##### Direction of rotation, fans and fan shroud

**The direction of rotation must be stated in every order!**

On 2-pole motors, the external fan is a low-noise, direction-dependent axial fan. 4-pole and 6-pole motors are equipped with a direction-neutral radial fan.

The external fan is covered by a sheet-steel shroud.

##### Vibration response

H-compact Standardline motors comply with vibration severity grade N as stipulated by IEC 60034-14, or grade A according to the revised version of IEC 60034-14 (valid from December 2006). The vibration levels remain well below limit values in most cases.

##### Insulation system

The SIEMENS-MICALASTIC® insulation system, tried and tested on high-power high-voltage motors for many years, has been used on the H-compact Standardline range.

The MICALASTIC insulation system complies with temperature class F, thermally utilized according to B (in normal operation).

An important element is the VPI (Vacuum Pressure Impregnation) process which is specially tailored to this insulation system.

The winding is resistant to system transfers with 100% residual field and switching operations up to 110% with phase opposition.

The surge withstand capability of the insulation satisfies insulation coordination requirements. The insulation properties exceed the values ( $V_p = 4 \times V_{rated} + 5 \text{ kV}$ ) stipulated in DIN EN 60034-15/VDE 0530-15.

##### Noise

H-compact Standardline motors are low-noise machines. This is achieved by:

- Motor construction designed for low noise
- Optimization of external ventilation
- Fans with good air-flow form design
- Noise-optimized construction of steel fan shroud
- Number of stator and rotor slots carefully selected for low magnetic noise excitation

##### Switching frequency

H-compact Standardline motors are designed for continuous operation in accordance with IEC / VDE 0530 Part 1. The permissible switching frequency limit is 5000 starts per year.

## Operation on supply system

### Connection box 1XA8711

Rated voltage 6.6 kV, up to 315 A, 3 connections (M16) for mains connection

- Up to 240 mm<sup>2</sup> conductor cross section with cable lug in accordance with DIN 46234,
- Up to 400 mm<sup>2</sup> conductor cross section with cable lug in accordance with DIN 46235,
- Alternatively, connection without cable lug,

Internal ground connection

Mounted on motor on RHS at DE (looking towards the DE shaft end).

As an option, the connection box can be mounted on LHS at DE, rotated through an angle of 90° or 180°.

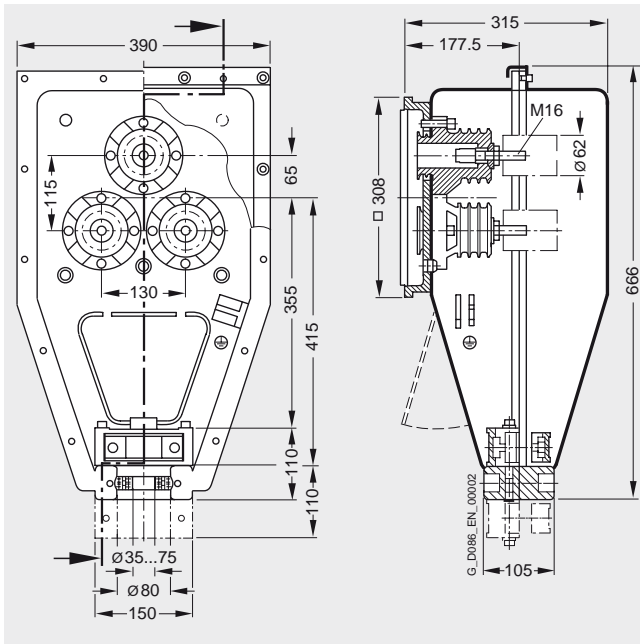

### Auxiliary connection box 1XB9014

The auxiliary connection box is designed to hold connections for connecting monitoring elements, heating, etc. It is made of aluminum and is shipped as standard with a cable entry plate without drill holes. This means that the cable entry parameters do not need to be clarified in advance when the motor is ordered. The plate is secured by 2 or 4 screws and can be removed easily for machining with the required entry holes.

- Dimensions (W x D x H): 360 x 160 x 90 mm
- No. of connections: 35
- Max. box mounting height: 50 mm

### Paint finish

Two paint systems - standard paint and special paint - are available for protecting motors against corrosion. They satisfy the following requirements relating to environmental conditions:

The **Standard paint** is categorized in the "Moderate" climate group as specified by IEC 721-2-1.

It is suitable for

- installation indoors or outdoors under cover, without direct natural weathering.
- Temperatures up to +120 °C for short periods or +100 °C continuously.
- Rel. air humidity up to 100% at temperatures up to +30 °C for short periods, up to 85% at temperatures up to +25 °C continuously.

Normal paint system:

- Primer approx. 30 µm on parts which can be dipped (casting), approx. 60 µm on parts which can be sprayed (steel)
- Final coat approx. 30 µm

The **Special paint** is categorized in the "Worldwide" climate group as specified by IEC 721-2-1.

It is suitable for

- installation outdoors with direct exposure to solar radiation and weathering over a wide temperature and humidity range (industrial or coastal areas are typical installation sites).
- Temperatures up to +140 °C for short periods or +120 °C continuously.

Special paint system:

- Primer approx. 30 µm on parts which can be dipped (casting), approx. 60 µm on parts which can be sprayed (steel)
- Final coat approx. 60 µm

The primer coat is applied to internal and external surfaces, the final coat to external surfaces.

Increased total film thicknesses, e.g. 120 or 150 µm, are available at an additional cost.

### Bearing construction

The motors are equipped with deep-groove ball bearings in accordance with DIN 625.

The location bearing is positioned at the DE.

All rolling-contact bearings are lubricated with mineral-oil-based lithium soap grease. The bearings have a re-greasing device with flat grease nipple M10 x 1 to DIN 3404 and a collector for used grease which is large enough to cover the calculated bearing life when the re-greasing intervals and quantities are observed (lubrication data can be found on lubrication plate or in order documentation).

The rolling-contact bearings are sealed externally by V-ring seals and internally by gap seals.

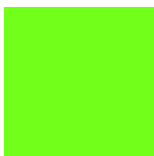

<b>5/2</b>	<b>Siemens contacts worldwide</b>
<b>5/3</b>	<b>A&amp;D Online Services</b>
5/3	Information and Ordering in the Internet and on CD-ROM
<b>5/4</b>	<b>Customer Support</b>
5/4	Our Services for Every Phase of Your Project
5/5	Knowledge Base and Automation Value Card
<b>5/6</b>	<b>Metal surcharges</b>
5/6	Explanation of the metal factor
5/7	Values of the metal factor
<b>5/8</b>	<b>Conditions of sale and delivery</b>
	<b>Export regulations</b>

# Appendix

## Siemens Contacts Worldwide



At

<http://www.siemens.com/automation/partner>

you can find details of Siemens contact partners worldwide responsible for particular technologies.

You can obtain in most cases a contact partner for

- Technical Support,
- Spare parts/repairs,
- Service,
- Training,
- Sales or
- Consultation/engineering.

You start by selecting a

- Country,
- Product or
- Sector.

By further specifying the remaining criteria you will find exactly the right contact partner with his/her respective expertise.

### A&D in the WWW



A detailed knowledge of the range of products and services available is essential when planning and configuring automation systems. It goes without saying that this information must always be fully up-to-date.

The Siemens Automation and Drives Group (A&D) has therefore built up a comprehensive range of information in the World Wide Web, which offers quick and easy access to all data required.

Under the address

<http://www.siemens.com/automation>

you will find everything you need to know about products, systems and services.

### Product Selection Using the Offline Mall of Automation and Drives

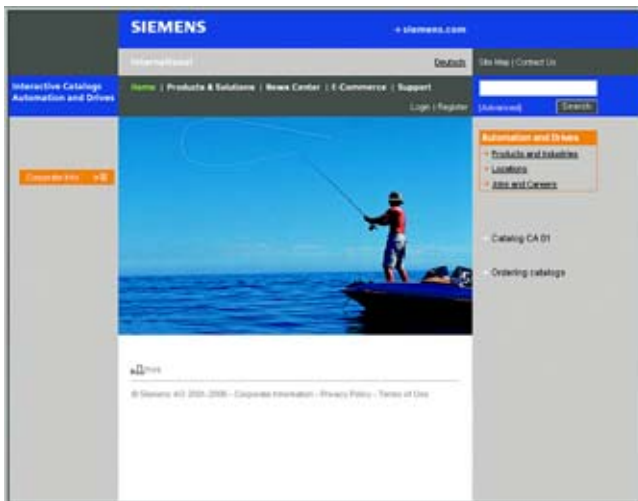

Detailed information together with convenient interactive functions:

The Offline Mall CA 01 covers more than 80,000 products and thus provides a full summary of the Siemens Automation and Drives product base.

Here you will find everything that you need to solve tasks in the fields of automation, switchgear, installation and drives. All information is linked into a user interface which is easy to work with and intuitive.

After selecting the product of your choice you can order at the press of a button, by fax or by online link.

Information on the Offline Mall CA 01 can be found in the Internet under

<http://www.siemens.com/automation/ca01>

or on CD-ROM or DVD.

### Easy Shopping with the A&D Mall



The A&D Mall is the virtual department store of Siemens AG in the Internet. Here you have access to a huge range of products presented in electronic catalogs in an informative and attractive way.

Data transfer via EDIFACT allows the whole procedure from selection through ordering to tracking of the order to be carried out online via the Internet.

Numerous functions are available to support you.

For example, powerful search functions make it easy to find the required products, which can be immediately checked for availability. Customer-specific discounts and preparation of quotes can be carried out online as well as order tracking and tracing.

Please visit the A&D Mall on the Internet under:

<http://www.siemens.com/automation/mall>

# Appendix Customer Support

## Our Services for Every Phase of Your Project



In the face of harsh competition you need optimum conditions to keep ahead all the time:

A strong starting position. A sophisticated strategy and team for the necessary support - in every phase.

Service & Support from Siemens provides this support with a complete range of different services for automation and drives.

In every phase: from planning and startup to maintenance and upgrading.

Our specialists know when and where to act to keep the productivity and cost-effectiveness of your system running in top form.

### Configuration and Software Engineering



Support in configuring and developing with customer-oriented services from actual configuration to implementation of the automation project. <sup>1)</sup>

### Service On Site



With Service On Site we offer services for startup and maintenance, essential for ensuring system availability.

In Germany  
**0180 50 50 444 <sup>1)</sup>**

### Online Support



The comprehensive information system available round the clock via Internet ranging from Product Support and Service & Support services to Support Tools in the Shop.

<http://www.siemens.com/automation/service&support>

### Repairs and Spare Parts



In the operating phase of a machine or automation system we provide a comprehensive repair and spare parts service ensuring the highest degree of operating safety and reliability.

In Germany  
**0180 50 50 446 <sup>1)</sup>**

### Technical Support



Competent consulting in technical questions covering a wide range of customer-oriented services for all our products and systems.

Tel.: +49 (0)180 50 50 222  
Fax: +49 (0)180 50 50 223  
<http://www.siemens.com/automation/support-request>

### Optimization and Upgrading



To enhance productivity and save costs in your project we offer high-quality services in optimization and upgrading. <sup>1)</sup>

### Technical Consulting



Support in the planning and designing of your project from detailed actual-state analysis, target definition and consulting on product and system questions right to the creation of the automation solution. <sup>1)</sup>

<sup>3)</sup> For country-specific telephone numbers go to our Internet site at: <http://www.siemens.com/automation/service&support>

## Knowledge Base on CD-ROM



For locations without online connections to the Internet there are excerpts of the free part of the information sources available on CD-ROM (Service & Support Knowledge Base). This CD-ROM contains all the latest product information at the time of production (FAQs, Downloads, Tips and Tricks, Updates) as well as general information on Service and Technical Support.

The CD-ROM also includes a full-text search and our Knowl-

edge Manager for targeted searches for solutions. The CD-ROM will be updated every 4 months.

Just the same as our online offer in the Internet, the Service & Support Knowledge Base on CD comes complete in 5 languages (German, English, French, Italian, Spanish).

You can order the **Service & Support Knowledge Base** CD from your Siemens contact.

Order no. **6ZB5310-0EP30-0BA2**

Orders via the Internet (with Automation Value Card or credit card) at:

<http://www.siemens.com/automation/service&support>

in the Shop domain.

## Automation Value Card



### Small card - great support

The Automation Value Card is an integral component of the comprehensive service concept with which Siemens Automation and Drives will accompany you in each phase of your automation project.

It doesn't matter whether you want just specific services from our Technical Support or want to purchase high-quality Support Tools in our Online Shop, you can always pay with your Automation Value Card. No invoicing, transparent and safe. With your personal card number and associated PIN you can view the state of your account and all transactions at any time.

Services on card. This is how it's done.

Card number and PIN are on the back of the Automation Value Card. When delivered, the PIN is covered by a scratch field, guaranteeing that the full credit is on the card.

By entering the card number and PIN you have full access to the Service & Support services being offered. The charge for the services procured is debited from the credits on your Automation Value Card.

All the services offered are marked in currency-neutral credits, so you can use the Automation Value Card worldwide.

### Automation Value Card order numbers

Credits	Order no.
200	<b>6ES7 997-0BA00-0XA0</b>
500	<b>6ES7 997-0BB00-0XA0</b>
1000	<b>6ES7 997-0BC00-0XA0</b>
10000	<b>6ES7 997-0BG00-0XA0</b>

Detailed information on the services offered is available on our Internet site at:

<http://www.siemens.com/automation/service&support>

Service & Support à la Card: Examples

### Technical Support

"Priority"	Priority processing for urgent cases
"24 h"	Availability round the clock
„Extended“	Technical consulting for complex questions

### Support Tools in the Support Shop

"System Utilities"	Tools that can be used directly for configuration, analysis and testing
"Applications"	Complete topic solutions including ready-tested software
"Functions & Samples"	Adaptable blocks for accelerating your developments

## Metal surcharges

### Explanation of the metal factor

Surcharges will be added to the prices of products that contain silver, copper, aluminum, lead and/or gold if the respective basic official prices for these metals are exceeded.

The surcharges will be determined based on the following criteria:

- Official price of the metal  
Official price on the day prior to receipt of the order or prior to the release order (=daily price) for  
- silver (sale price of the processed material),  
- gold (sale price of the processed material)  
Source: Umicore, Hanau  
(<http://www.metalsmanagement.umicore.com>)  
and for  
- copper (low DEL notation + 1%),  
- aluminum (aluminum in cables) and  
- lead (lead in cables)  
Source: German Trade Association for Cables and Conductors  
(<http://www.kabelverband.de>)
- Metal factor of the products  
Certain products are assigned a metal factor. The metal factor determines the official price as of which the metal surcharges are charged and the calculation method used (weight or percentage method). An exact explanation is given below.

### Structure of the metal factor

The metal factor consists of several digits; the first digit indicates whether the method of calculation refers to the list price or a discounted price (customer net price) (L = list price / N = customer net price).

The remaining digits indicate the method of calculation used for the respective metal. If no surcharge is added, a "-" is used.

1st digit	List or customer net price using the percentage method
2nd digit	for silver (AG)
3rd digit	for copper (CU)
4th digit	for aluminum (AL)
5th digit	for lead (PB)
6th digit	for gold (AU)

### Weight method

The weight method uses the basic official price, the daily price and the raw material weight. In order to calculate the surcharge, the basic official price must be subtracted from the daily price. The result is then multiplied by the raw material weight.

The basic official price can be found in the table below using the number (2 to 9) of the respective digit of the metal factor. The raw material weight can be found in the respective product descriptions.

### Percentage method

Use of the percentage method is indicated by the letters A-Z at the respective digit of the metal factor.

The surcharge is increased - dependent on the deviation of the daily price compared with the basic official price - using the percentage method in "steps" and consequently offers surcharges that remain constant within the framework of this "step range". A higher percentage rate is charged for each new step. The respective percentage level can be found in the table below.

### Metal factor examples

#### LEA---

Basis for % surcharge: List price  
Silver: basis 150 €, step range 50 €, 0.5%  
Copper: basis 150 €, step range 50 €, 0.1 %  
No surcharge for aluminum  
No surcharge for lead  
No surcharge for gold

#### N-A6--

Basis for % surcharge: Customer net price  
No surcharge for silver  
Copper: basis 150 €, step range 50 €, 0.1 %  
Aluminum acc. to weight, basic offic. price 225 €  
No surcharge for lead  
No surcharge for gold

#### --3---

No basis necessary  
No surcharge for silver  
Copper acc. to weight, basic official price 150 €  
No surcharge for aluminum  
No surcharge for lead  
No surcharge for gold

A&D/MZ\_1/En 05.09.06

## Values of the metal factor

Percentage method	Basic official price	Step range	% surcharge	% surcharge	% surcharge	% surcharge	% surcharge
			1st step	2nd step	3rd step	4th step	per additional step
			Official price	Official price	Official price	Official price	
			151 € – 200 €	201 € – 250 €	251 € – 300 €	301 € – 350 €	
A	150	50	0.1	0.2	0.3	0.4	0.1
B	150	50	0.2	0.4	0.6	0.8	0.2
C	150	50	0.3	0.6	0.9	1.2	0.3
D	150	50	0.4	0.8	1.2	1.6	0.4
E	150	50	0.5	1.0	1.5	2.0	0.5
F	150	50	0.6	1.2	1.8	2.4	0.6
G	150	50	0.7	1.4	2.1	2.8	0.7
H	150	50	1.2	2.4	3.6	4.8	1.2
I	150	50	1.6	3.2	4.8	6.4	1.6
J	150	50	1.8	3.6	5.4	7.2	1.8
K	150	50	2.0	3.5	5.0	6.5	1.5
L	150	50	2.2	4.4	6.6	8.8	2.2
M	150	50	2.5	5.0	7.5	10.0	2.5
			176 € – 225 €	226 € – 275 €	276 € – 325 €	326 € – 375 €	
O	175	50	0.1	0.2	0.3	0.4	0.1
P	175	50	0.2	0.4	0.6	0.8	0.2
Q	175	50	0.3	0.6	0.9	1.2	0.3
R	175	50	0.5	1.0	1.5	2.0	0.5
			226 € – 275 €	276 € – 325 €	326 € – 375 €	376 € – 425 €	
S	225	50	0.2	0.4	0.6	0.8	0.2
T	225	50	0.5	1.0	1.5	2.0	0.5
U	225	50	1.0	2.0	3.0	4.0	1.0
V	225	50	1.0	1.5	2.0	3.0	1.0
W	225	50	1.2	2.5	3.5	4.5	1.0
			126 € – 150 €	151 € – 175 €	176 € – 200 €	201 € – 225 €	
X	125	25	1.9	3.8	5.7	7.6	1.9
			151 € – 175 €	176 € – 200 €	201 € – 225 €	226 € – 250 €	
Y	150	25	0.3	0.6	0.9	1.2	0.3
			401 € – 425 €	426 € – 450 €	451 € – 475 €	476 € – 500 €	
Z	400	25	0.1	0.2	0.3	0.4	0.1
<b>Price basis (1st digit)</b>							
L	Charged on the list price						
N	Charged on the customer net price or discounted list price						
<b>Weight method</b>	<b>Basic official price</b>						
2	100						
3	150						
4	175						
5	200	Calculation based on raw material weight					
6	225						
7	300						
8	400						
9	555						
<b>Misc.</b>							
–	No metal surcharge						

## Conditions of sale and delivery Export regulations

### Terms and Conditions of Sale and Delivery

By using this catalog you can acquire hardware and software products described therein from Siemens AG subject to the following terms. Please note! The scope, the quality and the conditions for supplies and services, including software products, by any Siemens entity having a registered office outside of Germany, shall be subject exclusively to the General Terms and Conditions of the respective Siemens entity. The following terms apply exclusively for orders placed with Siemens AG.

#### For customers with a seat or registered office in Germany

The "General Terms of Payment" as well as the "General Conditions for the Supply of Products and Services of the Electrical and Electronics Industry" shall apply.

For software products, the "General License Conditions for Software Products for Automation and Drives for Customers with a Seat or registered Office in Germany" shall apply.

#### For customers with a seat or registered office outside of Germany

The "General Terms of Payment" as well as the "General Conditions for Supplies of Siemens Automation and Drives for Customers with a Seat or registered Office outside of Germany" shall apply.

For software products, the "General License Conditions for Software Products for Automation and Drives for Customers with a Seat or registered Office outside of Germany" shall apply.

#### General

The dimensions are in mm. In Germany, according to the German law on units in measuring technology, data in inches only apply to devices for export.

Illustrations are not binding.

Insofar as there are no remarks on the corresponding pages, - especially with regard to data, dimensions and weights given - these are subject to change without prior notice.

The prices are in € (Euro) ex works, exclusive packaging.

The sales tax (value added tax) is not included in the prices. It shall be debited separately at the respective rate according to the applicable legal regulations.

Prices are subject to change without prior notice. We will debit the prices valid at the time of delivery.

Surcharges will be added to the prices of products that contain silver, copper, aluminum, lead and/or gold, if the respective basic official prices for these metals are exceeded. These surcharges will be determined based on the official price and the metal factor of the respective product.

The surcharge will be calculated on the basis of the official price on the day prior to receipt of the order or prior to the release order.

The metal factor determines the official price as of which the metal surcharges are charged and the calculation method used. The metal factor, provided it is relevant, is included with the price information of the respective products. An exact explanation of the metal factor can be found on the page entitled "Metal surcharges".

The texts of the Comprehensive Terms and Conditions of Sale and Delivery are available free of charge from your local Siemens business office under the following Order Nos.:

- 6ZB5310-0KR30-0BA1  
(for customers based in Germany)
- 6ZB5310-0KS53-0BA1  
(for customers based outside of Germany)

or download them from the Internet  
<http://www.siemens.com/automation/mall>  
(Germany: A&D Mall Online-Help System)

### Export regulations

The products listed in this catalog / price list may be subject to European / German and/or US export regulations.

Therefore, any export requiring a license is subject to approval by the competent authorities.

According to current provisions, the following export regulations must be observed with respect to the products featured in this catalog / price list:

AL	Number of the <u>German Export List</u> Products marked other than "N" require an export license. In the case of software products, the export designations of the relevant data medium must also be generally adhered to. Goods labeled with an " <u>AL</u> " not equal to "N" are subject to a European or German export authorization when being exported out of the EU.
ECCN	<u>Export Control Classification Number</u> . Products marked other than "N" are subject to a reexport license to specific countries. In the case of software products, the export designations of the relevant data medium must also be generally adhered to. Goods labeled with an " <u>ECCN</u> " not equal to "N" are subject to a US re-export authorization.

Even without a label or with an "AL: N" or "ECCN: N", authorization may be required due to the final destination and purpose for which the goods are to be used.

The deciding factors are the AL or ECCN export authorization indicated on order confirmations, delivery notes and invoices.

Errors excepted and subject to change without prior notice.

A&D/VuL\_mit MZ/En 05.09.06

# Catalogs of the Automation and Drives Group (A&D)

Further information can be obtained from our branch offices listed  
in the appendix or at [www.siemens.com/automation/partner](http://www.siemens.com/automation/partner)

<b>Automation and Drives</b>	<i>Catalog</i>		
Interactive catalog on CD-ROM and on DVD			
• The Offline Mall of Automation and Drives	CA 01		
<b>Automation Systems for Machine Tools</b>			
SINUMERIK & SIMODRIVE	NC 60		
SINUMERIK & SINAMICS	NC 61		
<b>Drive Systems</b>			
<u>Variable-Speed Drives</u>			
SINAMICS G110/SINAMICS G120	D 11.1		
Inverter Chassis Units			
SINAMICS G120D			
Distributed Frequency Inverters			
SINAMICS G130 Drive Converter Chassis Units, SINAMICS G150 Drive Converter Cabinet Units	D 11		
SINAMICS GM150/SINAMICS SM150	D 12		
Medium-Voltage Converters			
SINAMICS S120 Drive Converter Systems	D 21.1		
SINAMICS S150 Drive Converter Cabinet Units	D 21.3		
Asynchronous Motors Standardline	D 86.1		
Synchronous Motors with Permanent-Magnet Technology, HT-direct	D 86.2		
DC Motors	DA 12		
SIMOREG DC MASTER 6RA70 Digital Chassis Converters	DA 21.1		
SIMOREG K 6RA22 Analog Chassis Converters	DA 21.2		
SIMOREG DC MASTER 6RM70 Digital Converter Cabinet Units	DA 22		
SIMOVERT PM Modular Converter Systems	DA 45		
SIEMOSYN Motors	DA 48		
MICROMASTER 410/420/430/440 Inverters	DA 51.2		
MICROMASTER 411/COMBIMASTER 411	DA 51.3		
SIMOVERT MASTERDRIVES Vector Control	DA 65.10		
SIMOVERT MASTERDRIVES Motion Control	DA 65.11		
Synchronous and asynchronous servomotors for SIMOVERT MASTERDRIVES	DA 65.3		
SIMODRIVE 611 universal and POSMO	DA 65.4		
<u>Low-Voltage Three-Phase-Motors</u>			
IEC Squirrel-Cage Motors	D 81.1		
<u>Automation Systems for Machine Tools SIMODRIVE</u>	NC 60		
• Main Spindle/Feed Motors			
• Converter Systems SIMODRIVE 611/POSMO			
<u>Automation Systems for Machine Tools SINAMICS</u>	NC 61		
• Main Spindle/Feed Motors			
• Drive System SINAMICS S120			
<u>Drive and Control Components for Hoisting Equipment</u>	HE 1		
<b>Electrical Installation Technology</b>			
<i>PDF: ALPHA Small Distribution Boards and Distribution Boards, Terminal Blocks</i>	ETA 1		
<i>PDF: ALPHA 8HP Molded-Plastic Distribution System</i>	ETA 3		
<i>PDF: BETA Low-Voltage Circuit Protection</i>	ET B1		
<i>PDF: DELTA Switches and Socket Outlets</i>	ET D1		
GAMMA Building Controls	ET G1		
<b>Human Machine Interface Systems SIMATIC HMI</b>	ST 80		
<b>Industrial Communication for Automation and Drives</b>		<i>Catalog</i>	IK PI
<b>Low-Voltage</b>			
Controls and Distribution – SIRIUS, SENTRON, SIVACON			LV 1
Controls and Distribution – Technical Information SIRIUS, SENTRON, SIVACON			LV 1 T
SIDAC Reactors and Filters			LV 60
SIVENT Fans			LV 65
SIVACON 8PS Busbar Trunking Systems			LV 70
<b>Motion Control System SIMOTION</b>			PM 10
<b>Process Instrumentation and Analytics</b>			
Field Instruments for Process Automation			FI 01
Measuring Instruments for Pressure, Differential Pressure, Flow, Level and Temperature, Positioners and Liquid Meters			
<i>PDF: Indicators for panel mounting</i>			MP 12
SIREC Recorders and Accessories			MP 20
SIPART, Controllers and Software			MP 31
SIWAREX Weighing Systems			WT 01
Continuous Weighing and Process Protection			WT 02
Process Analytical Instruments			PA 01
<i>PDF: Process Analytics, Components for the System Integration</i>			PA 11
<b>SIMATIC Industrial Automation Systems</b>			
SIMATIC PCS Process Control System			ST 45
Products for Totally Integrated Automation and Micro Automation			ST 70
SIMATIC PCS 7 Process Control System			ST PCS 7
Add-ons for the SIMATIC PCS 7 Process Control System			ST PCS 7.1
Migration solutions with the SIMATIC PCS 7 Process Control System			ST PCS 7.2
pc-based Automation			ST PC
SIMATIC Control Systems			ST DA
<b>SIMATIC Sensors</b>			
Sensors for Factory Automation			FS 10
<b>SIPOS Electric Actuators</b>			
Electric Rotary, Linear and Part-turn Actuators			MP 35
Electric Rotary Actuators for Nuclear Plants			MP 35.1/2
<b>Systems Engineering</b>			
Power supplies SITOP power			KT 10.1
System cabling SIMATIC TOP connect			KT 10.2
<b>System Solutions</b>			
Applications and Products for Industry are part of the interactive catalog CA 01			
<b>TELEPERM M Process Control System</b>			
<i>PDF: AS 488/TM automation systems</i>			PLT 112

*PDF: These catalogs are only available as pdf files.*

[www.siemens.com/motors](http://www.siemens.com/motors)

**Siemens AG**

Automation and Drives  
Large Drives  
Postfach 47 43  
90025 NÜRNBERG  
GERMANY

[www.siemens.com/automation](http://www.siemens.com/automation)

*The information provided in this catalog contains descriptions or characteristics of performance which in case of actual use do not always apply as described or which may change as a result of further development of the products. An obligation to provide the respective characteristics shall only exist if expressly agreed in the terms of contract. Availability and technical specifications are subject to change without notice.*

*All product designations may be trademarks or product names of Siemens AG or supplier companies whose use by third parties for their own purposes could violate the rights of the owners.*

**Order No. E86060-K5586-A111-A2-7600**