



**Noise
Control**

**Shock
Control**

**Vibration
Control**

**Seismic
Control**



INTRODUCTION

NSV has manufactured noise, vibration and shock proof products for the past 30 years since its foundation on March 1 1986. Throughout it all, NSV has contributed to the development of the domestic construction industry. As the leading noise and vibration proof products manufacturer in Korea, NSV prides itself on providing the best service with the best technologies as part of its vision of creating a pleasant environment. Moreover, NSV has continued to invest in developing creative products and increasing the sales of its world-class products. All NSV members promise to not to rest on their laurels, but to do their best to enable NSV to become the leading company in the world, serving both customers and society.

OVERVIEW

| CORPORATE NAME

NSV Co., Ltd.

| PRESIDENT

EUNJOONG YOON

| SEOUL OFFICE

3F, 28, Hyoryeong-ro 55-gil, Seocho-gu, Seoul, Republic of Korea
TEL : +82-2-598-1988 FAX : +82-2-598-1989

| HEAD OFFICE AND FACTORY

89, Namdong-daero 36beon-gil, Namdong-gu, Incheon, Republic of Korea
TEL : +82-32-812-2015 FAX : +82-32-812-2014

| R&D CENTER

89, Namdong-daero 36beon-gil, Namdong-gu, Incheon, Republic of Korea
TEL : +82-32-816-7992 FAX : +82-32-816-7993

| ESTABLISHED ON

1986.03.01

| BUSINESS

Noise and vibration proof facilities (noise/vibration fields)
engineering (noise/vibration fields), measurement (noise/vibration fields)
construction (machine and facilities installation/metal structure and joiner work)

| CERTIFICATES

ISO 9001, ISO 14001, KS certification, KC certification, OHSMS/OHSAS 18001





SERVICE AND PRODUCTS

| MANUFACTURING

- Noise/vibration/shockproof products
Silencer for air conditioning system (rectangular and circular types)
- Sound chamber, sound elbo
- Enclosure
- Reverberation chamber, anechoic room, echo room
- Dustproof mount, dustproof neoprene mount
- Dustproof pad
- Spring hanger, dustproof base
- Fixed spring hanger for piping, variable spring hanger for piping
- Plywood panel
- Air separator, multifunctional valve
- Water hammer arrestor (for sanitary, air-conditioning and fire-extinguishing purposes)
- FAN for ventilation
- Air spring, isolator
- Elastomeric bearing
- Earthquake shock absorber, earthquake-proof stopper
- Sound barrier
- Control measures for vibration induced by metro trains
- Control measures for factory noise/vibration
- Other noise/vibration/shockproof products

| ENGINEERING SERVICES

- Measurement and analysis of noise/vibration/shock
- Test and control measures for noise/vibration/shock
- Sound/dynamic analysis
- Other engineering services for special noise/vibration/shock

PRODUCT OVERVIEW

NOISE CONTROL

ANOS10 Rectangular Type Sound Attenuator / (Previously named RUP)

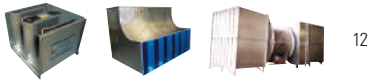

12

ANOS20 Circular Type Sound Attenuator / (Previously named CP)



15

SC Sound Attenuating Chamber



16

SE Sound Attenuating Elbow



16

AL-A/B Acoustic Louver



17

ANOS50 Hybrid Type Silencer (Resonance+Expansion Type Silencer) / (Previously named ANOS)



18

SD Sound Absorbing Duct



20

IS Industrial silencer



21

SPR Soundproof Room



22

SPD Soundproof Door



23

SW Soundproof Window



23

NDP Damping Sheets



24

NDT Damping Tape

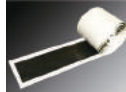

24

AR Anechoic Room



25

ER Reverberation Room

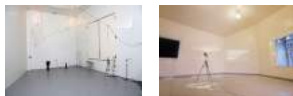

25

PO-MAT[®] Polyurethane Mat



26

HD-MAT High-Damping Mat



31

HE-MAT High-Elasticity Mat

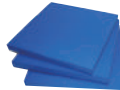

33

NP-MAT Neoprene Mat



34

EP-MAT EVA Mat



34

JUM-10000/20000/30000/40000 Jack Up Mount



35

NFM Plywood Floating Floor System



39

NFA Fiber Glass Sound Absorbing Board



41

WM1 / WM2 / WM3 Isolated Stud Neoprene Mount



42

SHOCK CONTROL

WHA Water Hammer Arrester (CM Adapter/PB Coupling Type)



50

WHA-3000 STS Sanitary Water Hammer Arrester (CM Adapter)



51

WHA-4000 Water Hammer Arrester (Flange Type)



52

WHA-5000 Water Hammer Arrester (Line Type)



53

WHA-6000 Water Hammer Arrester (Flange Type)



54

VD10 Friction & Wire Damper / (Previously named VDT)



55

VD20 Vibration Friction Damper / (Previously named VFD)



56

VD30 Seismic Total Damper / (Previously named VWD)



57

SC Swivel Connector



58

VIBRATION CONTROL

SMA Spring Mount (Deflection : 25mm)



66

2SMA Spring Mount (Deflection : 25mm)



68

SMA2 Spring Mount (Deflection : 50mm)



70

SMB Spring Mount (Deflection : 25mm)



72

SMB2 Spring Mount (Deflection : 50mm)



74

NSM/NSM2 Spring Mount (Deflection : 25mm, 50mm)



76

FSL Spring Mount (Deflection : 25mm)



78

FSL2 Spring Mount (Deflection : 50mm)



80

SMA3 Spring Mount (Deflection : 75mm)



82

FSL3 Spring Mount (Deflection : 75mm)



83

SH Spring Hanger (Deflection : 25mm)



84

VH20 Spring Hanger (Deflection: 25mm)/(Previously named VH)



86

VH61 Spring Hanger (Deflection: 25mm)/(Previously named VSH)



87

VH62 Spring Hanger (Deflection: 50mm)/(Previously named VSH2)



88

RH10 Rubber Hanger (Deflection: 3.5-13mm)/(Previously named RH)



90

RH20 Ceiling Rubber Hanger (Deflection: 5mm)/(Previously named CH)



91

RH30 Rubber Hanger (Deflection : 3.5-5mm)/(Previously named VHB)



91

RH40 Spring Rubber Hanger (Deflection: 11mm)/(Previously named VHM)



92

NBN Rubber Bushing Nut (Deflection : 3-8mm)



92

NTR Thrust Restraint (Deflection : 25mm)

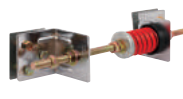

93

NTR2 Thrust Restraint (Deflection : 50mm)

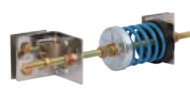

94

RPA Pipe Anchor & Guide (Deflection : 3-9mm)



96

CLAMP Riser Pipe Clamp



98

VB-1000 Rubber Mount (Deflection: 5.0-9.0mm)/(Previously named VB)



100

VB-1030H Rubber Oval Mount (Deflection: 5.0-9.0mm)/(Previously named VB0-30)



100

VB-2000 Rubber Mount (Deflection : 11-20mm)/(Previously named VO)



102

VM-1000 Rubber Mount (Deflection : 6-8mm)



102

VM-2000 Rubber Mount (Deflection : 8mm)



103

VM-3000 Rubber Mount (Deflection: 6mm)



103

VM-4000 Rubber Mount (Deflection: 6-16mm)



104

VM-5000 Rubber Mount (Deflection: 15mm)



104

VC Conical Mount (Deflection: 15mm)



107

SRP Spring Rubber Pad (Deflection: 5.5-7mm)



109

SRM Spring Rubber Mount (Deflection: 5.5mm)



111

SRA Spring Rubber Mount (Deflection: 6-12mm)



112

SRH-U Spring Rubber Mount (Deflection: 5.5mm)



113

PRODUCT OVERVIEW

VIBRATION CONTROL

SRH-SH Spring Rubber Mount (Deflection: 5.5mm)



114

VP-1000 Rubber Pad (Deflection : 4~10mm)

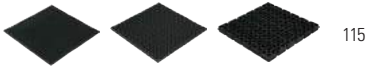

115

VP-2000 Rubber Pad (Deflection : 3~6mm)



116

VP-3000 Rubber Pad (Deflection : 6/12mm)



116

IB Inertia Base Series



118

SB Elasticity Structural Base



119

NFC10S Flexible Connector / (Previously named NFC-S)



120

NFC10 Flexible Connector / (Previously named NFC-1)



120

NFC20 Flexible Connector / (Previously named NFC-2)

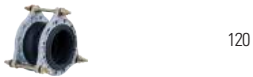

120

NV10 Flexible Connector / (Previously named NVC)



122

VD60 Spring Damper Mount / (Previously named VDM)



123

VAM10 Air Mount (Airpressure: 1.5~6Kg/mm) / (Previously named VAM)



124

VAM20 Pneumatic Leveling Isolator / (Previously named VAD)



125

VAM90 Pneumatic Isolation Table / (Previously named VAT)



125

VF Foot Rubber Mount (Deflection: 3.5mm)



126

VWM10 Wire Mount / (Previously named VWM)



127

VWM20 Wire Mount / (Previously named VWR)



128

VWM51 Wire-Spring Mount (Deflection: 25mm) / (Previously named VWA)



129

VWM52 Wire-Spring Mount (Deflection: 50mm) / (Previously named VWA2)



130

VWM62 Wire-Spring Mount (Deflection: 50mm) / (Previously named VWS)



132

SEISMIC CONTROL

NSS-A



134

NSS-B



135

NSS-C



136

NSS-D



137

NSS-E

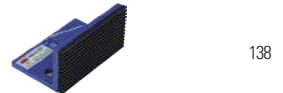

138

NSS-F



139

NSS-G



140

NSS-H



140

NSS-I



140

Noise
Control



ISO 9001/ISO 14001
OHSAS 18001
MADE IN KOREA



NOISE CONTROL

Principles of Noise

1. The definition of noise

► Sound

As the pressure change waves by the transformation of medium particles, something people can hear.

► Noise

Usually defined as unwanted sound : an undesirable by-product of society's normal day-to-day activities.



$$RMS = \sqrt{\frac{1}{T} \int_0^T \{P(t)\}^2 dt}$$

Here, T : period

P(t) : change in sound pressure with time lapse

For pure sound. $RMS = \frac{P}{\sqrt{2}}$

7) Acoustic Velocity

Propagation velocity of sound waves in specific media, with uniform result in equal media.

$$C = \lambda f$$

Acoustic velocity in the air

$$C \approx 20\sqrt{T} \approx 331.5 + 0.6\theta \text{ (m/s)}$$

Here, T=absolute temperature

=centigrade temperature (°C)

About 340m/s at normal temperature (°C)

8) 3 Element of sound

| | Physical amount | Unit | Felling Limits |
|----------------------|-------------------------------------|---------------------|-------------------------------|
| Strong /Weak | Wavelength of Sound Pressure Change | Sound Pressure (Pa) | $2 \times 10^{-5} \sim 60$ Pa |
| High /Low | Frequency of Sound Pressure Change | Frequency (Hz) | 20 ~ 20000 Hz |
| Sound Property Value | Composition of Sound Frequency | Frequency Spectrum | |

2. Terms of Sound

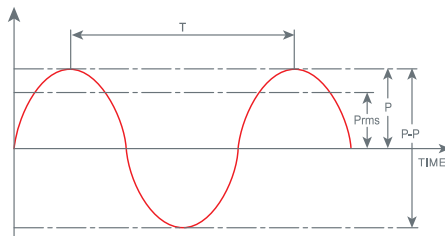

1) Wave length (λ)

Distance of pressure distribution repeated in space repeat.

2) Period(T)

The time necessary for one change of pressure variation repeat once.

3) Frequency (f)

The repetition of pressure changes per second.

4) Amplitude (Peak, P)

Maximum pressure of change from standard pressure (atmospheric pressure).

5) Peak to Peak amplitude (P-P)

Width of change between maximum and minimum pressure.

6) Effective value (Root Mean Square, RMS)

Sound wave's mean value of energy

9) Sound Synthesis

► Sound synthesis addition table

| Level Difference | 0 | 1 | 2 | 3 | 4 | 5 | 6 | 7 | 8 | 9 | OVER 10 |
|------------------|---|---|---|---|---|---|---|---|---|---|---------|
| Additional Value | 3 | 2 | | | | | | 1 | | | 0 |

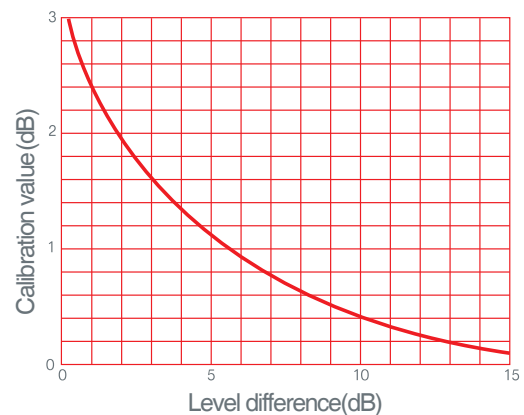

$$\begin{matrix} \text{Speaker} + \text{Speaker} = \text{Speakers} \\ 80 + 80 = 83 \\ \underline{160} \end{matrix}$$

10) Average of Sound Pressure Level (SPL)

$$\overline{SPL} = SPL - 10 \log n$$

Here, n : The number of Sound Source.

11) Sound Pressure Level Difference (Δ SPL)

$$\Delta SPL = 10 \log(10^{SPL_1/10}) - 10 \log(10^{SPL_2/10})$$

► Difference Calculation table of Sound

| Level Difference | 3 | 4 | 5 | 6 | 7 | 8 | 9 | OVER 10 |
|------------------|----|----|---|---|----|---|---|---------|
| Additional Value | -3 | -2 | | | -1 | | | 0 |

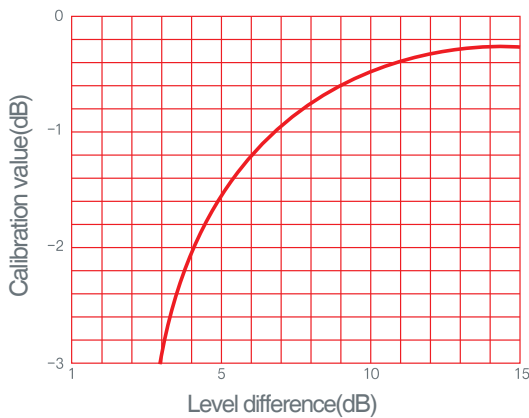

$$\begin{matrix} \text{House} - \text{Car} = \text{House} \\ 64 - 60 = 62 \end{matrix}$$

12) Background Noise Calibration

Finding the object noise level through the difference between measuring noise and background noise.

13) Sound Diffraction

Sound energy-diffusion caused by the formation of second wave back of a hole or the hole itself Inverse ratio between frequency and diffraction.

14) STC (Sound Transmission Class)

Transmission class : As the index of sound-insulation efficiency, Sound transmission loss at 500Hz in STC diagram satisfies specified conditions.

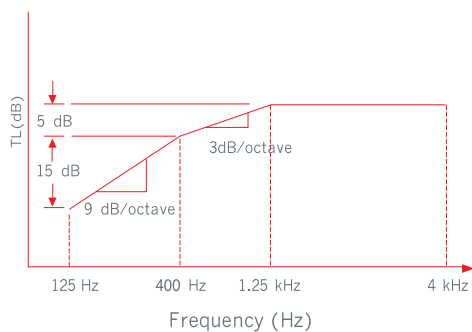

- ① Standard STC contour 16 between 125Hz and 4KHz, centering on 1/3 octave on the basis of frequency value.
- ② Any loss value 8dB below STC diagram value should not exist.
- ③ The total of transmission loss smaller than standard STC diagram value should be below 32dB.

15) Reverberation Time

The time elapsed when room noise level falls from initial level to 60dB after sound stopped.

The acoustical absorptivity of materials and the room sound-absorption are measured.

3. Effects of Noise

A. Definition of Terms

- 1) TTS (Temporary Threshold Shift) : Temporary hardness of hearing.
- 2) PTS (Permanent Threshold Shift) : Permanent loss of hearing sense.
- 3) Hardness of hearing due to bad working environment : Loss of hearing starts at 4,000Hz.
- 4) Geriatric hardness of hearing: Loss of hearing starts at frequency of more than 10,000Hz.
- 5) Average loss of hearing = $\frac{2+2b+c}{4}$ [dB]

Here, a : loss of hearing at 500Hz

b : loss of hearing at 1,000Hz

c : loss of hearing at 2,000Hz

6) Masking Effect

The phenomenon of certain sounds reducing a person's ability to hear other sounds.

7) Equivalent Hearing Sensitivity Curve

The graph is drawn by linking the point of sound pressure level of same amplitude of labial which people can feel according to each frequency.

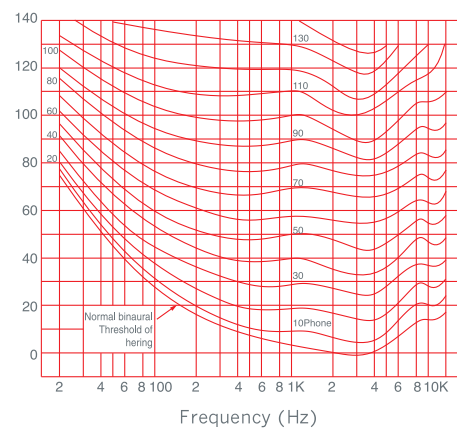

Principles of Noise

B. Estimation of Noise

1) Loudness (Phone)

By connecting the degrees of noise as having the same loudness, drawing an equivalent hearing curve and showing a sound pressure level of 1,000Hz.

2) dB(A)

As people's hearing changes according to frequency, one way to estimate noise on the basis of loudness people feel is by calibrating the sound according to its frequency.

This is closely related to human response. Similar noise estimation methods include dB(B), dB(C) and dB(D).

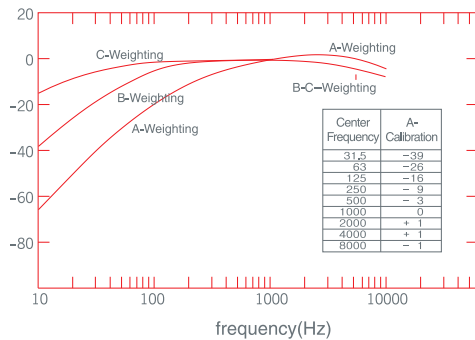

3) Noise-Criteria Curves

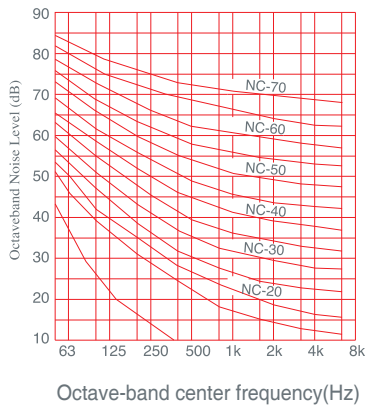

| | 63 | 125 | 250 | 500 | 1K | 2K | 4K | 8K |
|------|----|-----|-----|-----|----|----|----|----|
| NC65 | 80 | 75 | 71 | 68 | 66 | 64 | 63 | 62 |
| NC60 | 77 | 71 | 67 | 63 | 61 | 59 | 58 | 57 |
| NC55 | 74 | 67 | 62 | 58 | 56 | 54 | 53 | 52 |
| NC50 | 71 | 64 | 58 | 54 | 51 | 49 | 48 | 47 |
| NC45 | 67 | 60 | 54 | 49 | 46 | 44 | 43 | 42 |
| NC40 | 64 | 56 | 50 | 45 | 41 | 39 | 38 | 37 |
| NC35 | 60 | 52 | 45 | 40 | 37 | 34 | 33 | 32 |
| NC30 | 57 | 48 | 41 | 35 | 31 | 29 | 28 | 27 |
| NC25 | 54 | 44 | 37 | 31 | 27 | 24 | 22 | 21 |
| NC20 | 51 | 40 | 33 | 26 | 22 | 19 | 17 | 16 |
| NC15 | 47 | 36 | 29 | 22 | 17 | 14 | 12 | 11 |

Based on disturbance in conversation and noise, this is one way to estimate noise, by degree of disrupting human life. In an NC curve which is made by connecting sound pressure levels showing a similar response, sound pressure level reaches a value of about 1,500Hz. This is widely used to estimate room noise.

$$NC = dB(A) - (5 \sim 7)$$

4) Room-Criteria Curves

HVAC-related sound is often the primary type of background sound that exists in many indoor n AC background sound is present the use of NC criteria has often resulted in a poor correlation between the calculated NC criteria and an individual's subjective response to corresponding background sound. The tangent method used to determine the NC criteria is not sensitive to the way in which people subjectively respond to background sound. People can respond differently to background sound source that have the same NC levels, but have different spectrum shapes. Spectrum shapes similar to the NC curves in the figure(e both Octave-band center frequency) are not very pleasant sounding. They will usually have both a low frequency rumbles and high frequency hiss. As a means of overcoming the above shortcomings associated with NC curves, Blazier introduced the room criteria(RC) curves shown in figure as below(Blazier 1981). The curves, as they relate to HVAC system background sound, are based on : sound pressure levels, spectrum shapes or valance, tonal content or spectrum, and temporal fluctuations in the sound pressure levels.

RC criteria was the primary method recommended by AHSRAE for determining the acceptability of background HVAC related sound unoccupied indoor area. As will be discussed in the next section, it has been replaced by the RC MARK II method. The RC curves shown on the below figure extend from the 16Hz through the 4,000Hz octave band. These are the general frequency limits for sound produced by HVAC systems. Technical data, based in recognized standards, for the relevant properties of mechanical and architectural building components are not available for frequencies as low as the 16Hz octave bands. In some cases technical data may extend to the 63Hz octave

band; however in the most cases, the data only extend to the 125Hz octave band. When determining the RC criterion of a room based on calculated octave band sound pressure levels, the lower frequency limit of the analysis can only extend to the frequency for which valid data exist. When determining the RC criteria based on the measured octave band sound pressure levels, the lower frequency limit of the analysis is determined by the capabilities of the instruments used to make the sound measurements. Most modern instruments measure down to 16Hz octave

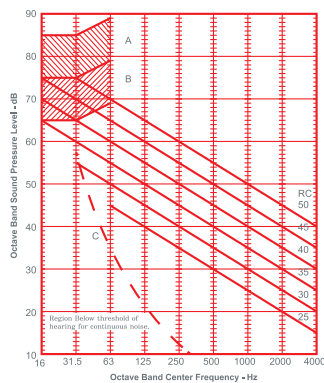

C. Measures Against Solid-Borne Noise

After soundwaves are emitted directly from the source, they are transferred through the air and heard. This is called “air-borne noise.” But after it is transmitted to solid matter from the source, it vibrates inside until finally radiated into the air by the form of a sound which can be heard, or is into the air through vibration and can be heard. This is called solid-borne noise or structure-borne noise.

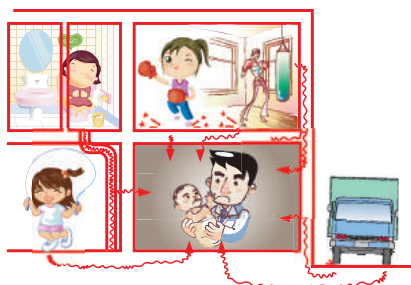

(Solid-borne noise)

There are two spheres : 1~100Hz is felt by the muscles and 20~20,000Hz can be heard. The vibration and the solid-borne noise overlap at

20~100Hz, but at around 40Hz, hearing becomes more sensitive. So only sounds of more than 40Hz are the object of solid borne noise



(Air-borne noise)

1) How to Prevent Solid-Borne Noise

Solid-borne noise is divided into generation, vibration transmission, and sound emission fields. For generation sound, the vibration (in the form of energy) should be reduced. Second, vibration speed (increasing the mass of the machine) should be reduced. Third, by reducing the impedance in the support part, the transmission at the same vibration is decreased.

Effective measures at contact point between source and transmission field include buffering and vibration proofing. By using soft elastic or plastic material, the former prolongs the impact time and lowers the maximum impact power, effectively reducing the natural frequency and decreasing input energy. But, on the contrary, constructing centralized-purity type proper-vibration fields reduces the substantial transmission of exciting force via the difference in impedance.

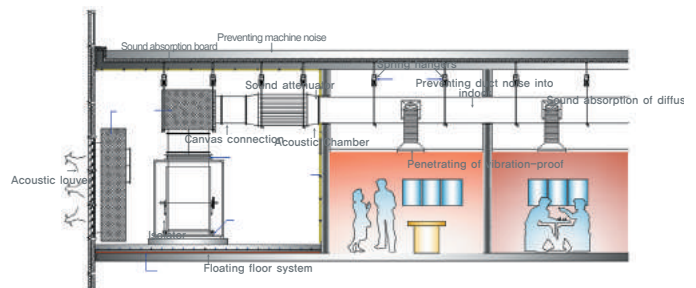

2) Anti-Noise System for solid-borne noise

- Jack up floating floor system(JUM)
- Plywood panel system(NFM)
- Polyurethane mat(PO-MAT)

ANOS10 Rectangular Type Sound Attenuator

■ Features

ANOS10 is useful in reducing the noise transmission through the HVAC system and by adjusting air way gap between the splitters inside; the noise problem can be resolved. In general, it offers excellent sound attenuation in 500~8000Hz.



Splitter Type

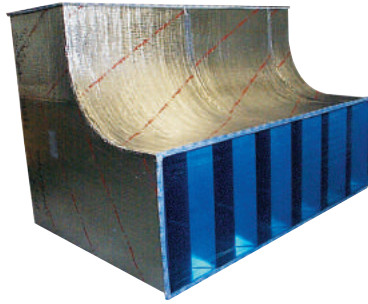

Elbow Type

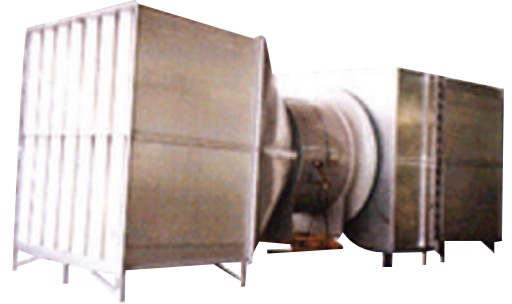

In-Line Type

■ Model Denotation method



- ① Splitter Shape
- ② Absorption Material Protection Method
- ③ Sound Attenuator Shape
- ④ Splitter Thickness / Air Way Area Ratio Type(S, L, M Type)
- ⑤ Sound Attenuator Width(mm)
- ⑥ Sound Attenuator Height(mm)
- ⑦ Sound Attenuator Length(mm)

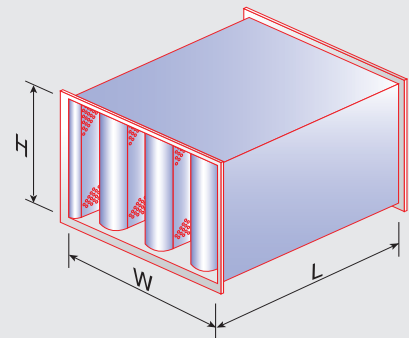

■ Splitter Shape



■ Absorption Material Protection Method

- G : GLASS WOOL + GLASS CLOTH
- P : GLASS WOOL + GLASS CLOTH + PERFORATED PLATE
- F : GLASS WOOL + GLASS CLOTH + PE FILM + PERFORATED PLATE

■ Sound Attenuator Shape

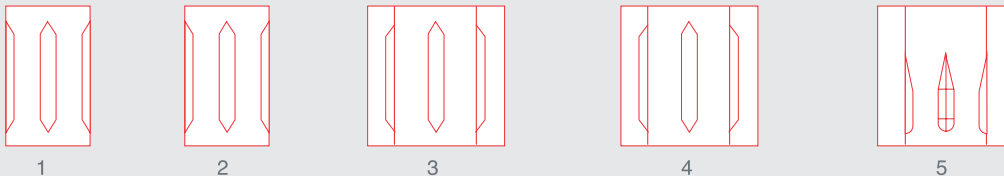

■ Splitter Thickness / Air Way Area

- S Type : Large pressure loss and self noise and large amount of noise attenuation thru all of the frequency band.
- L Type : Small pressure loss and self noise and large amount of noise attenuation for middle/high frequency band.
- M Type : Middum amount of pressure loss and self noise and large amount of noise attenuation for 250Hz/500Hz.

ANOS10 Rectangular Type Sound Attenuator

■ Analysis Of Velocity Distribution Per Splitter Type

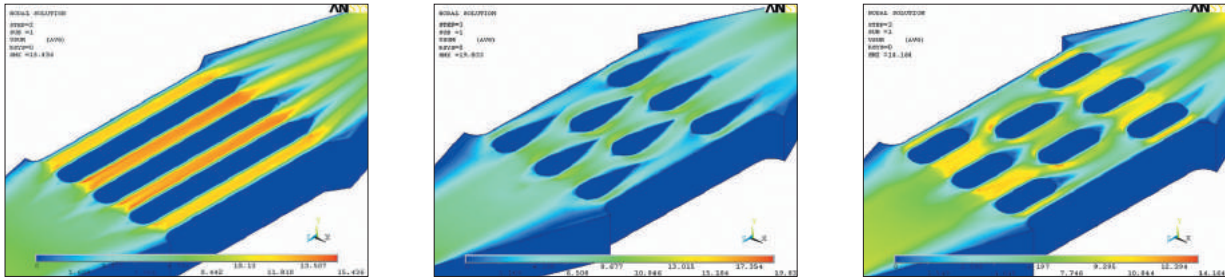

■ Sound Attenuator Calculation Sheet

| | | | | | | | | |
|----------|--------------|-----------------|-----------------|---------------|------------|-----------------------|-----------|--------------------------------------|
| Model | AHU-01(S) | Air Flow | 20900 CMH(m³/h) | DUCT SIZE | 1400 X 600 | Static Efficiency | 90% | } INFORMATION OF EQUIPMENT & PROJECT |
| Project | Project Name | | | Service | Office | Quantity | 1 SET | |
| Location | - | Static Pressure | 107 mmAq | Diffuser Type | SQUARE | Duct Airflow Velocity | 6.9 m/sec | |

| | | OCTAVE BAND CENTER FREQUENCY(Hz) | | | | | | | | | |
|--|---|---|-------|--------------|--------|--------|------|------|------|------|------|
| | | 63 | 125 | 250 | 500 | 1000 | 2000 | 4000 | | | |
| 1. Fan Total Sound Power Level (PWL) | CODE 2 | AIR FOIL | | | | | | | | | |
| 1) Specific Sound Power Level (Kw) | | 45.0 | 45.0 | 43.0 | 39.0 | 34.0 | 28.0 | 24.0 | | | |
| 2) Sound Level by Air Flow & Static Pressure (Mw) | | 53.4 | 53.4 | 53.4 | 53.4 | 53.4 | 53.4 | 53.4 | | | |
| 3) Correction Factor by Efficiency (C) | | 0.0 | 0.0 | 0.0 | 0.0 | 0.0 | 0.0 | 0.0 | | | |
| 4) Blade Frequency Increments (BFI) | | 0.0 | 0.0 | 3.0 | 0.0 | 0.0 | 0.0 | 0.0 | | | |
| (Total) | | 98.4 | 98.4 | 99.4 | 92.4 | 87.4 | 81.4 | 77.4 | | | |
| 2. Attenuation of System | | Total Sound Power Level : 94.7dB(A) | | | | | | | | | |
| 1) Unlined Rectangular Sheet Metal Ducts | | | | | | | | | | | |
| a.Rectangular Duct | | Width | Hight | P/A | Length | | | | | | |
| Duct - 1 | | 1.40 | 0.60 | 4.76 | 10 | 3.0 | 3.0 | 3.0 | 3.0 | 3.0 | 3.0 |
| Duct - 2 | | 0.0 | 0.00 | 0.00 | 0 | 0.0 | 0.0 | 0.0 | 0.0 | 0.0 | 0.0 |
| b.Circular Duct | | | | | | | | | | | |
| 2) Insertion Loss of Elbow | | | | | | | | | | | |
| a.Square Elbow | | Q'TY | 0 | Width | 1.40 | 0.0 | 0.0 | 0.0 | 0.0 | 0.0 | 0.0 |
| b.Round Elbow | | Q'TY | 0 | Width | 0.00 | 0.0 | 0.0 | 0.0 | 0.0 | 0.0 | 0.0 |
| c.Lined Elbow | | Q'TY | 0 | Width | 0.00 | 0.0 | 0.0 | 0.0 | 0.0 | 0.0 | 0.0 |
| 3) Chamber Attenuation (Non-Sound-Absorbing) | | Q'TY | 0 | 0 | NRC | 0.00 | 0.0 | 0.0 | 0.0 | 0.0 | 0.0 |
| 4) Chamber Attenuation (Sound-Absorbing) | | Q'TY | | Inlet | 3 mmAq | Outlet | 0.0 | 0.0 | 0.0 | 0.0 | 0.0 |
| 5) Duct Branch Sound Power Division | | Inlet | 0.8 | NRC | 0.8 | | | | | | |
| 6) Duct End Reflection Loss | | Air Volume | 780 | m²/h | | 14.3 | 14.3 | 14.3 | 14.3 | 14.3 | 14.3 |
| 7) The Other Attenuation | | Q'TY | | N.D | 0.25 | 16.0 | 11.0 | 6.0 | 2.0 | 1.0 | 0.0 |
| (Total) : 1)+2)+3)+4)+5)+6)+7) | | | | | | | | | | | |
| 3. Sound Power Level in Room (PWL) | (Sum1 - Sum2) | Code 6 | | | | | | | | | |
| 4. Noise Criteria in Room(SPL) | | 65.1 | 70.1 | 76.1 | 73.0 | 69.1 | 64.1 | 60.1 | | | |
| 5. Correction by Diffuser Sound Pressure (-10log ne+10log ni) ne=0.23 ni=0.7 | | 4.8 | 4.8 | 4.8 | 4.8 | 4.8 | 4.8 | 4.8 | | | |
| 6. Attenuation to Room Absorption (Kr) | | Width | 5 | α | 0.01 | | | | | | |
| | | Length | 5 | α | 0.01 | | | | | | |
| | | Hight | 4.0 | α (Ave) | 0.01 | -4.9 | -4.9 | -4.9 | -4.9 | -4.9 | -4.9 |
| | | Area(m²) | 130 | Room Constan | 1.31 | | | | | | |
| 7. Allowable Sound Power Level at Outlet (PWL) : (4+5+6) | | 63.9 | 55.9 | 49.9 | 44.9 | 40.9 | 38.9 | 37.9 | | | |
| 8. Generated Noise at Outlet (PWL) | *Sound Power Level (Before Atten.) : 74.4 dB(A) | | | | | | | | | | |
| 9. Allowable Sound Power Level in Room (PWL) | | 63.9 | 55.9 | 49.9 | 44.9 | 40.9 | 38.9 | 37.9 | | | |
| 10. Additional Attenuation Required | (3-9) | 1.2 | 14.2 | 26.2 | 28.2 | 28.2 | 25.2 | 22.2 | | | |
| 11. Sound Attenuator | | *Air Velocity (Pass through Atten.) : 8.1 m/s | | | | | | | | | |
| (Insertion Loss) | 5 | Model | Width | Hight | Length | 7 | 8 | 14 | 23 | 31 | 33 |
| Pressure Drop | 3 mmAq | 1800 | 800 | 1500 | 7 | 11 | 16 | 26 | 37 | 37 | 20 |
| | | 1800 | 800 | 2100 | 8 | 11 | 19 | 30 | 43 | 41 | 24 |

ANOS10 Rectangular Type Sound Attenuator

■ Sound Trap Sound Attenuator Placement On Ahu Room

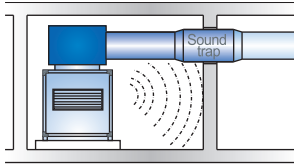

BEST

Controls ductborne noise and mechanical room noise that "breaks into" duct.

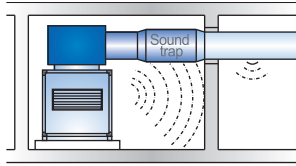

VERY GOOD

Practical alternate where fire damper is required at wall.

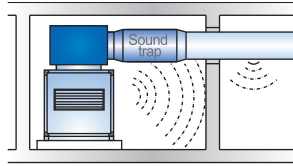

FAIR

Mechanical room noise "breaks into" duct without reduction through sound trap.

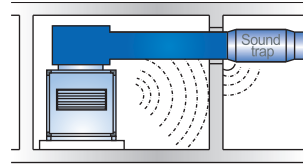

POOR

All noise in duct "breaks out" over occupied space before being reduced by sound trap.

■ Guidelines for sound trap placement near fans and duct fittings

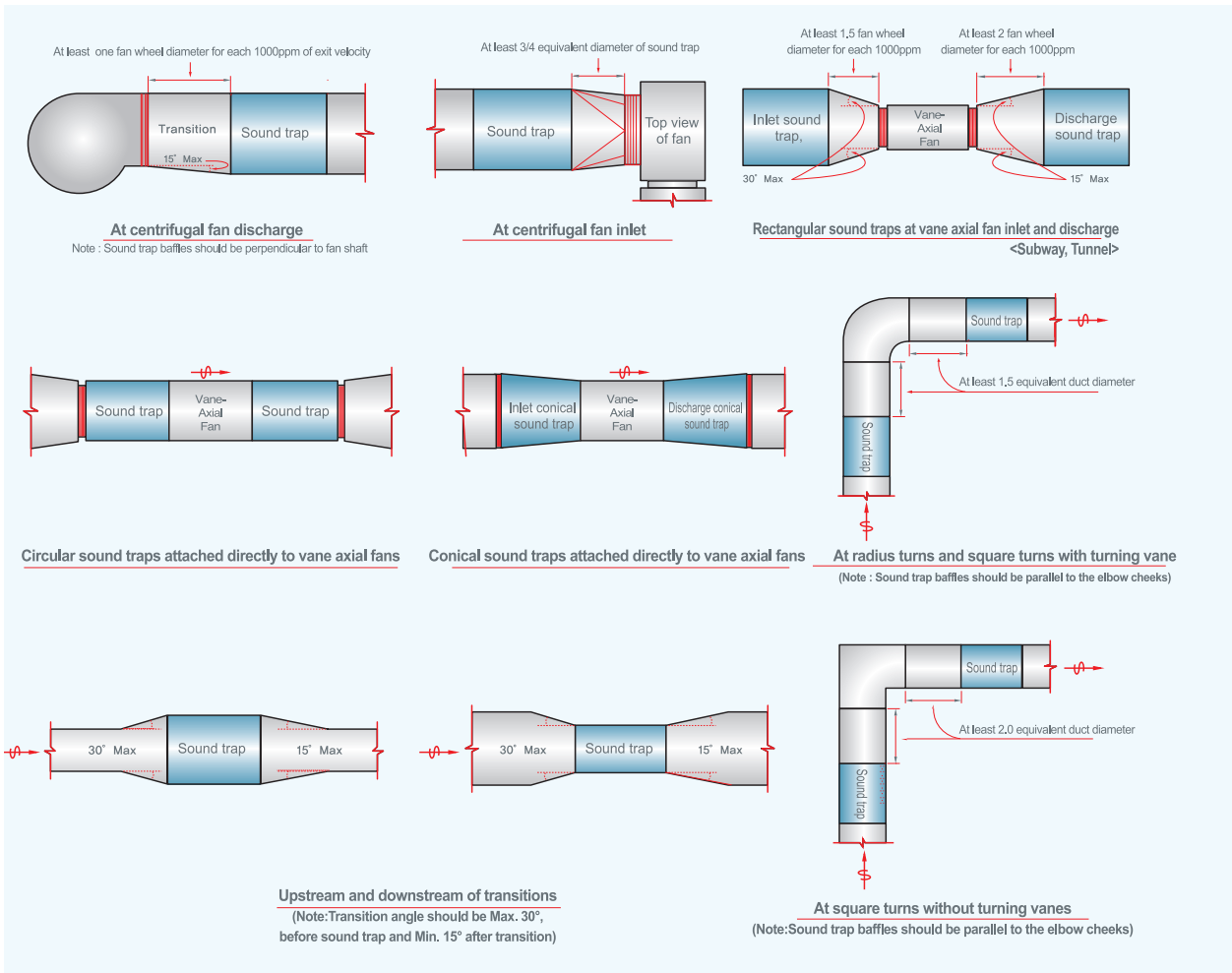

■ Installation features



ANOS20 Circular Type Sound Attenuator

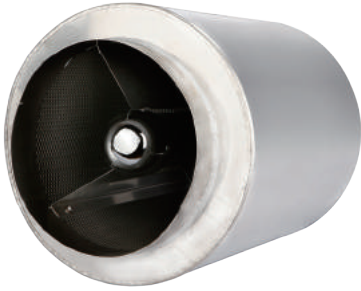

■ Features

The ANOS20 is used for HVAC systems and industrial machines. There are two types : one with a sound-absorbing material attached inside the attenuator and the other one with sound-absorbing cone mounted inside.

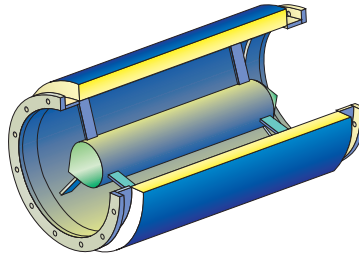

TYPE-1

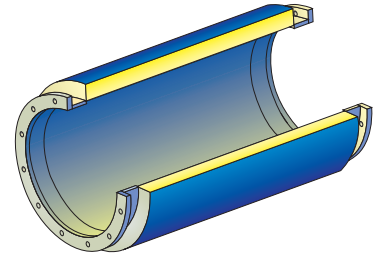

TYPE-2

■ Model denotation method



- ① Absorption Material Protection Method
- ② Sound Attenuator Shape
- ③ Splitter Thickness / Air Way Extension Type
- ④ Sound Attenuator Diameter(∅):A
- ⑤ Sound Attenuator Length(mm):L

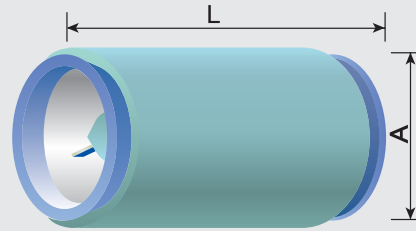

■ Absorption Material Protection Method

- G: GLASS WOOL + GLASS CLOTH
- P: GLASS WOOL + GLASS CLOTH + PERFORATED PLATE
- F: GLASS WOOL + GLASS CLOTH + PE FILM + PERFORATED PLATE

■ Sound Attenuator Shape

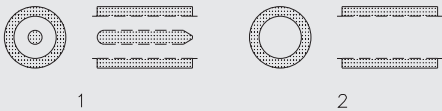

■ Splitter thickness/Air Way Extension

- S Type : Large pressure loss and self noise and large amount of noise attenuation thru all of the frequency band.
- L Type : Small pressure loss and self noise and large amount of noise attenuation for middle/high frequency band.

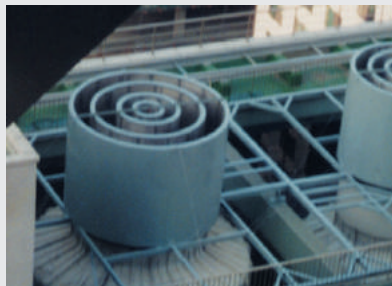

SC Sound Attenuating Chamber



■ Features

It is installed on the outlet or inlet of the air conditioner and fan to control turbulent flow and reduce noise. The SCF type is used for low-speed ducts, the SCP type for high-speed ducts and SCF type for clean rooms. An angle bracket is installed for robust structures and convenience. It is designed to use different interior material and installation methods depending on the main frequency of the air conditioner and fan. The noise attenuation of the sound chamber is in proportion to the sound-absorption rate of the interior material and installation area, but is in inverse proportion to the area of duct exit. It offers excellent sound attenuation in a medium/high frequency range.

■ Model denotation method

SC - × × ×

- ① Sound Absorption Material Protection Method
- ② Sound Absorption Material Thickness(mm)
- ③ Sound Attenuating Chamber Width(mm)
- ④ Sound Attenuating Height(mm)
- ⑤ Sound Attenuating Length(mm)

■ Sound Attenuating amount(R)

$$R = 10 \log \left\{ \frac{1}{S_e \left(\frac{\cos \theta}{2\pi d^2} + \frac{1-\bar{\alpha}}{\bar{\alpha} S_w} \right)} \right\} = 10 \log \left\{ \frac{A}{S_e} \right\}$$

- Here $\bar{\alpha}$: average absorption of the plenum lining
 S_e : plenum inlet or exit area(m² or ft²)
 S_w : plenum Wall area(m² or ft²)
 d : distance from input to output(m² or ft²)
 θ : (w-l)²+h²(m² or ft²)
 A : h/d

SE Sound Attenuating Elbow



■ Features

The sound attenuating elbow is installed in a right-angled corner to reduce noise and turbulent flow. The elbow interior material is attached only on the sides. Its thickness should be about 10% of the breadth of the duct with the length at least twice as as the duct. Sometimes, the turning vane is installed to reduce turbulent flow. In general, it works better in the medium/high frequency range, offering attenuation of up to 10dB in 500~1000Hz.

■ Model denotation method

SE - ×

- ① Sound Absorption Material Protection Method
- ② Sound Attenuating Elbow Width(mm)
- ③ Sound Attenuating Elbow Height(mm)

■ Absorption Material Protection Method

- G : GLASSWOOL + GLASS CLOTH
- P : GLASSWOOL + GLASS CLOTH + PERFORATED PLATE
- F : GLASSWOOL + GLASS CLOTH+ PE FILM + PERFORATED PLATE

■ Insertion Loss of Elbows

| Application | Elbow Type | Square Elbow | | | | Round Elbow |
|----------------|------------|-----------------------|--------------|--------------------|--------------|-----------------------|
| | | Without Turning vanes | | With Turning vanes | | Without Turning vanes |
| | | Unlined Elbows | lined Elbows | Unlined Elbows | lined Elbows | Unlined Elbows |
| *fw < 48 | | 0 | 0 | 0 | 0 | 0 |
| 48 ≤ fw < 96 | | 1 | 1 | 1 | 1 | 1 |
| 96 ≤ fw < 190 | | 5 | 6 | 4 | 4 | 2 |
| 190 ≤ fw < 380 | | 8 | 11 | 6 | 7 | 3 |
| 380 ≤ fw < 760 | | 4 | 10 | 4 | 7 | 3 |
| Fw ≥ 760 | | 3 | 10 | 4 | 7 | 3 |

* fw = f(Center Frequency:kHz) X w(Elbow Width:mm)

AL-A/B Acoustic Louver



■ Features

The acoustic louver is installed in a place having enough area for ventilation where the rectangular sound attenuator is not available, but needs to be soundproofed. The casing is made of a galvanized steel plate with the thickness of 1.0~2.3 mm, and the inside of the louver splitter is filled with sound-absorbing material. It can prevent damage against the air current speed of 30M/S and the size of the acoustic louver splitter should be at least 150 mm.

■ Specification

| Item | Name of Components | Thickness | Remark |
|-------------|------------------------|------------|--------------|
| Outer Plate | Galvanized Steel Plate | 1.0~2.3mm | - |
| | Punching Plate | Over 0.8mm | Ø5 x 7P, 46% |
| Splitter | Glass Cloth | 0.12mm | 18/25mm |
| | Glass Wool | Over 50mm | Over 40K |
| | Glass Cloth | 0.12mm | 18/25mm |
| | Punching Plate | Over 0.8mm | Ø5 x 7P, 46% |

■ Types of Acoustic Louver

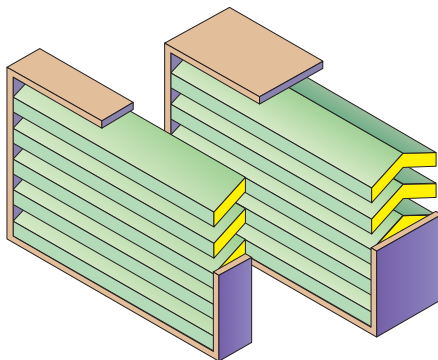

-Horizontal splitter-

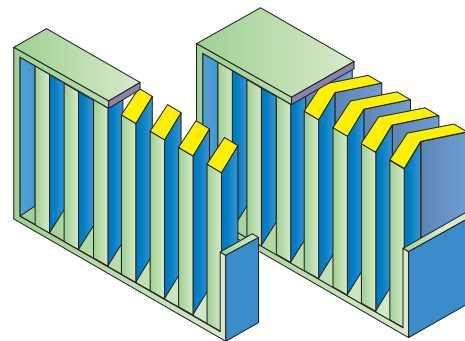

-Vertical splitter-

■ Installation features



ANOS50 Hybrid Type Silencer (Resonance+Expansion Type Silencer)

■ Why ANOS50 is needed

- To improve the quality of living – quiet and pleasant living environment
- Noise is the main cause of conflicts between neighbors
- Because ventilation pipes/ducts in the bathroom of an apartment or house are connected, noise is transferred next door, and therefore it is difficult to protect one's privacy.

■ ANOS50-125L/150L Specification

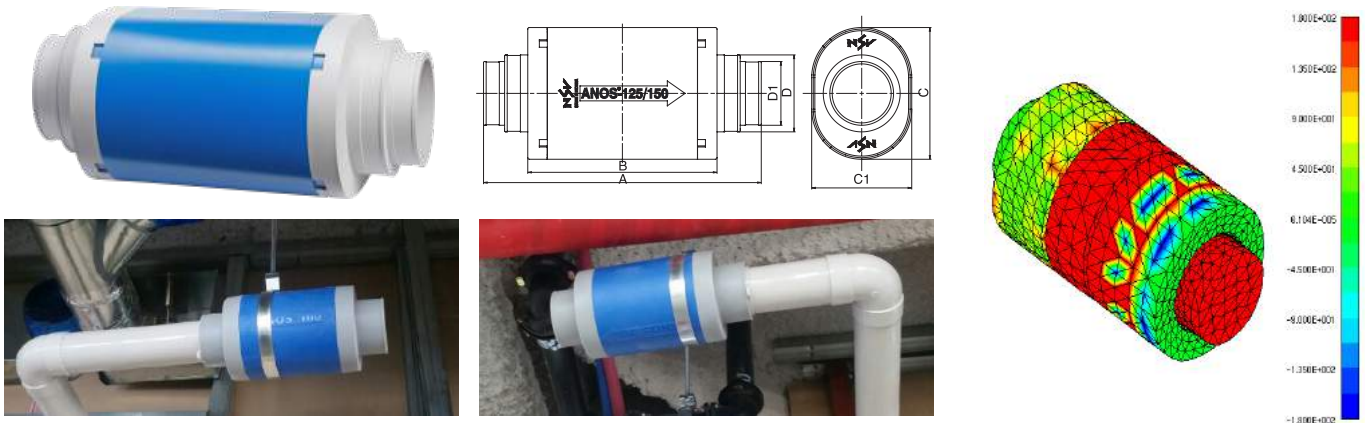

■ Specification

| Model | Dimension(mm) | | | | | | Type |
|----------------------------|---------------|-----|------|-----|------|------|----------|
| | A | B | C | C1 | D | D1 | |
| ANOS50-100A | 325 | 227 | ∅150 | - | ∅97 | - | Circular |
| ANOS50-125A ANOS50-150A | 528 | 360 | 250 | 190 | ∅145 | ∅121 | OVAL |

(NOTE) The mentioned size and scale can be altered to improve the quality performance and capacity of the product without any notice.

■ Characteristic

| Details | | Specification |
|------------------------------|--------------------------|---|
| Attenuation Performance | | Greater than 10dB(A) for daily life noise in apartment |
| Ventilation Specification | Pressure Loss | 0.3mmAq (based on Air flow speed of 5m/s in silencer) |
| | Ventilator Air Volume | 2.0 CMM (120CMH) |
| | Bathroom Air Circulation | Air circulation count 15 times/hr base (volume 8.0m ²) |
| Material [polypropylene(PP)] | | Material that is used to manufacture cooking ware harmless to human |
| | | Recyclable and eco-friendly material |
| | | When in combustion, no noxious gases are generated |
| product structure | | Assembly design that is easy to install and perform maintenance |

ANOS50 Hybrid Type Silencer (Resonance+Expansion Type Silencer)

■ ANOS50 Noise Level Test Data

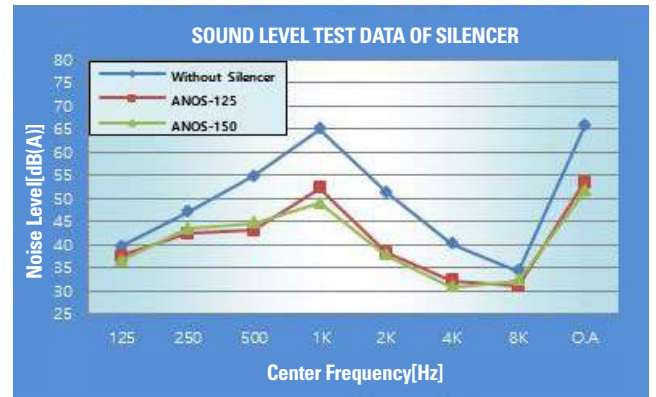
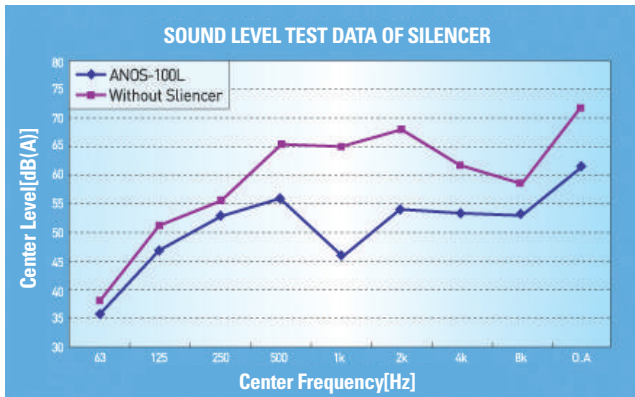

■ Effectiveness of ANOS50

- Reduces the level of noise generated in the bathroom down to that of background noise
- Excellent noise attenuation especially in 1~2KHz, which affects humans
- Protects privacy and maintains a quiet, pleasant living environment
- Helps avoid neighborly disputes and allows for the respect of privacy of one another

■ ANOS50 installation

- It can be installed on a ceiling and/or wall regardless of vent type
- It is easy to connect regardless of vent fan type
- It has a wide use of application, including kitchen hoods
- Its simple structure makes it easy to install, use and maintain

■ Bathroom Detailed drawing for ANOS50 installation

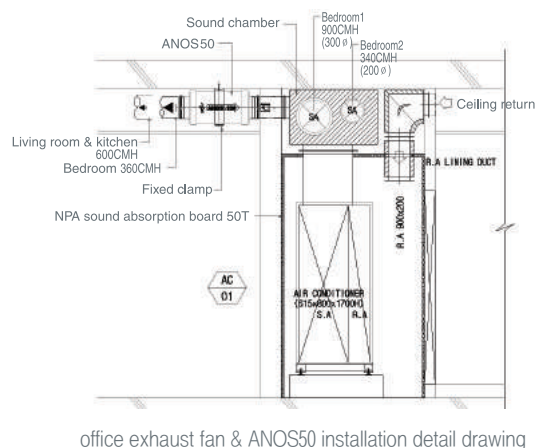
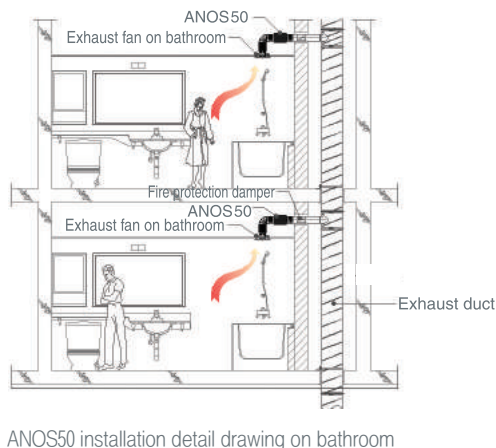
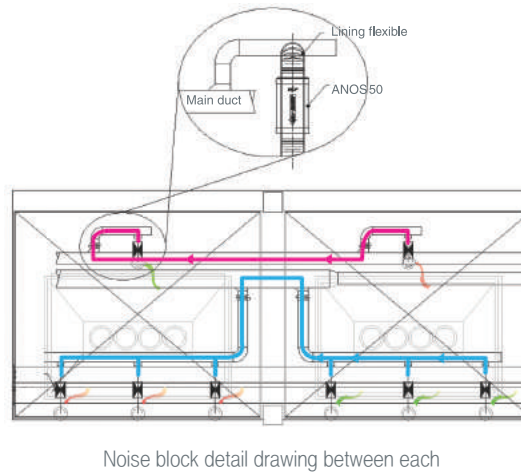
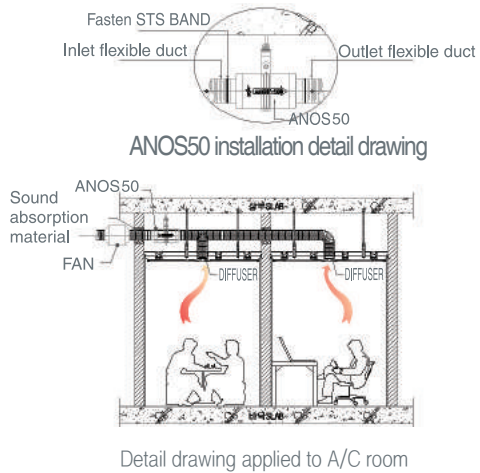

SD Sound Absorbing Duct

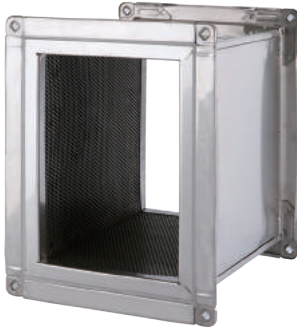

Features

It is installed on the outlet or inlet of the air conditioning units and fan, and in a place where soundproofing equipment such as sound arrester and sound chamber are not available because its installation is not constrained by space. It is easy to install and useful in reducing noise inside ducts and subsequent noise as well.

Model denotation method



- ① Method of protecting the sound-absorbing material
- ② Width of sound-absorbing duct(mm)
- ③ Height of sound-absorbing duct(mm)

Comparison of the sound-absorbing ducts' external insertion loss

| Dimensions | 63 | 125 | 250 | 500 | 1000 | 2000 | 4000 |
|-------------------|----|-----|-----|-----|------|------|------|
| Lined Duct 25t | 13 | 17 | 21 | 33 | 47 | 63 | 71 |
| Lined Duct 50t | 14 | 18 | 21 | 40 | 55 | 64 | 74 |
| 0.8t Unlined Duct | 9 | 12 | 17 | 21 | 27 | 32 | 37 |
| 1.0t Unlined Duct | 11 | 14 | 18 | 23 | 28 | 34 | 38 |
| 1.2t Unlined Duct | 12 | 15 | 20 | 25 | 30 | 35 | 39 |
| 1.6t Unlined Duct | 14 | 18 | 22 | 27 | 32 | 37 | 42 |
| 2.0t Unlined Duct | 16 | 20 | 24 | 29 | 34 | 39 | 43 |

Comparison of the sound-absorbing ducts' external insertion loss

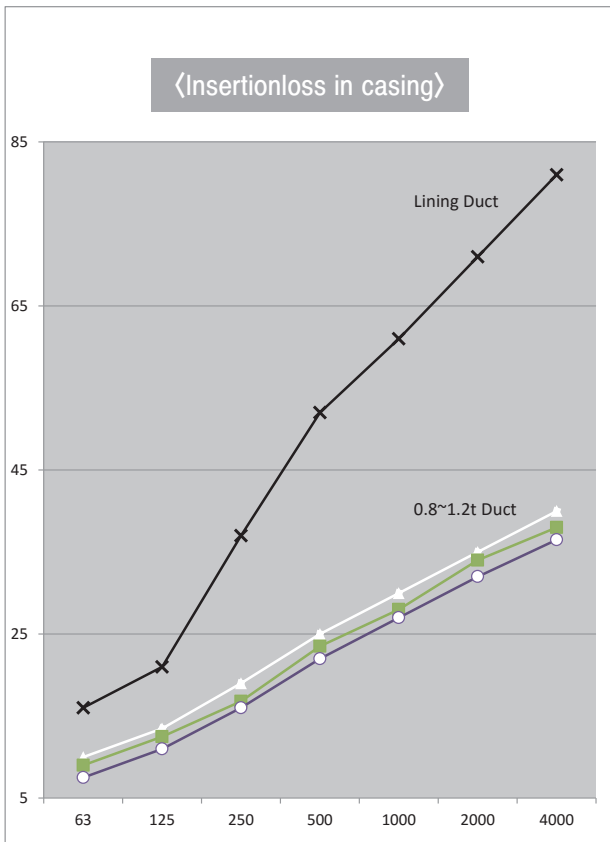

Sound attenuation amount of sound-absorbing duct (dB/m)

| Dimensions, mm | Insertion Loss(dB/m), Octave Band Center Frequency(Hz) | | | | | |
|----------------|--|-----|-----|------|------|------|
| | 125 | 250 | 500 | 1000 | 2000 | 4000 |
| 150 X 150 | 2.0 | 4.9 | 8.9 | 19.0 | 24.3 | 14.1 |
| 150 X 250 | 1.6 | 3.9 | 7.9 | 16.7 | 20.0 | 12.1 |
| 150 X 300 | 1.6 | 3.9 | 7.5 | 16.4 | 19.0 | 11.8 |
| 150 X 460 | 1.6 | 3.3 | 7.2 | 15.4 | 17.1 | 10.8 |
| 200 X 200 | 1.6 | 3.9 | 7.5 | 16.4 | 19.0 | 11.8 |
| 200 X 300 | 1.3 | 3.3 | 6.9 | 14.8 | 16.1 | 10.5 |
| 200 X 460 | 1.3 | 3.0 | 6.6 | 14.1 | 14.8 | 9.8 |
| 200 X 610 | 1.3 | 2.6 | 6.2 | 13.1 | 13.5 | 9.2 |
| 250 X 250 | 1.3 | 3.3 | 6.9 | 14.4 | 15.4 | 10.2 |
| 250 X 410 | 1.3 | 2.6 | 6.2 | 13.1 | 13.1 | 8.9 |
| 250 X 510 | 1.0 | 2.6 | 5.9 | 12.5 | 12.1 | 8.5 |
| 250 X 760 | 1.0 | 2.3 | 5.6 | 11.8 | 10.8 | 7.9 |
| 300 X 300 | 1.3 | 2.6 | 6.2 | 13.1 | 13.5 | 9.2 |
| 300 X 460 | 1.0 | 2.3 | 5.6 | 12.1 | 11.5 | 8.2 |
| 300 X 610 | 1.0 | 2.0 | 5.6 | 11.5 | 10.5 | 7.5 |
| 300 X 910 | 1.0 | 2.0 | 5.2 | 10.8 | 9.5 | 7.2 |
| 380 X 380 | 1.0 | 2.3 | 5.6 | 11.8 | 10.8 | 7.9 |
| 380 X 560 | 1.0 | 2.0 | 5.2 | 10.8 | 9.5 | 7.2 |
| 380 X 760 | 1.0 | 1.6 | 4.9 | 10.2 | 8.5 | 6.6 |
| 380 X 1140 | 0.7 | 1.6 | 4.6 | 9.5 | 7.9 | 6.2 |
| 460 X 460 | 1.0 | 2.0 | 5.2 | 10.8 | 9.5 | 7.2 |
| 460 X 710 | 0.7 | 1.6 | 4.6 | 9.8 | 7.9 | 6.2 |
| 460 X 910 | 0.7 | 1.6 | 4.7 | 9.2 | 7.2 | 5.9 |
| 460 X 1370 | 0.7 | 1.3 | 4.3 | 8.9 | 6.6 | 5.6 |
| 610 X 610 | 0.7 | 1.6 | 4.6 | 9.2 | 7.2 | 5.9 |
| 610 X 910 | 0.7 | 1.3 | 3.9 | 8.5 | 6.2 | 5.2 |
| 610 X 1220 | 0.7 | 1.3 | 3.9 | 7.9 | 5.6 | 4.9 |
| 610 X 1830 | 0.7 | 1.0 | 3.6 | 7.5 | 5.2 | 4.6 |
| 760 X 760 | 0.7 | 1.3 | 3.9 | 8.2 | 5.9 | 5.2 |
| 760 X 1140 | 0.7 | 1.0 | 3.6 | 7.5 | 5.2 | 4.6 |
| 760 X 1520 | 0.7 | 1.0 | 3.6 | 7.2 | 4.6 | 4.3 |
| 760 X 2290 | 0.3 | 1.0 | 3.3 | 6.9 | 4.3 | 3.9 |
| 910 X 910 | 0.7 | 1.0 | 3.6 | 7.5 | 5.2 | 4.6 |
| 910 X 1370 | 0.3 | 1.0 | 3.3 | 6.9 | 4.3 | 3.9 |
| 910 X 1830 | 0.3 | 1.0 | 3.3 | 6.6 | 3.9 | 3.9 |
| 910 X 1830 | 0.3 | 0.7 | 3.0 | 6.2 | 3.6 | 3.6 |
| 1070 X 1070 | 0.7 | 1.0 | 3.3 | 6.9 | 4.6 | 4.3 |
| 1070 X 1630 | 0.3 | 1.0 | 3.0 | 6.2 | 3.9 | 3.6 |
| 1070 X 2130 | 0.3 | 1.7 | 3.0 | 5.9 | 3.6 | 3.6 |
| 1070 X 3200 | 0.3 | 1.7 | 3.0 | 5.6 | 3.3 | 3.3 |
| 1220 X 1220 | 0.3 | 1.0 | 3.3 | 6.6 | 3.9 | 3.9 |
| 1220 X 1830 | 0.3 | 0.7 | 3.0 | 5.9 | 3.3 | 3.3 |
| 1220 X 2440 | 0.3 | 0.7 | 2.6 | 5.6 | 3.3 | 3.3 |
| 1220 X 3660 | 0.3 | 0.7 | 2.6 | 5.2 | 3.0 | 3.0 |

IS Industrial silencer



■ Features

When high-pressure fluid is released from the safety valve, the pressure control valve and relief valve release into the atmosphere, and the speed of running fluid changes into the speed of sound and produces friction with the surrounding air and swirl, which results in the generating of loud noise. In general, high-frequency noise is generated from the outlet and low-frequency noise is generated from a short distance away, and the result is noise which frequency components show the mixed form of high frequency and low frequency. In order to reduce such noise, it is required to find the frequency that has the lowest noise level.

■ Specification

It is effective in attenuating the sound of the audible frequency and noise generated when high-pressure gas or steam is released into the atmosphere. It consists of the diffuser that directs low-frequency sound toward high-frequency sound, the expansion chamber is for low-frequency noise control, the acoustic tube is for high frequency noise control and shell.

■ Model denotation method



- ① Sound Attenuator Type : I/IN-LINE TYPE, V/VENT TYPE
- ② Sound Attenuator Form : H/HORIZONTAL, V/VERTICAL
- ③ Diameter of the connecting hole(mm) A
- ④ Sound Attenuator Diameter(mm) B
- ⑤ Sound Attenuator Length(mm) C

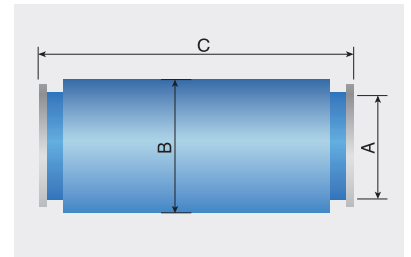

■ Model denotation method

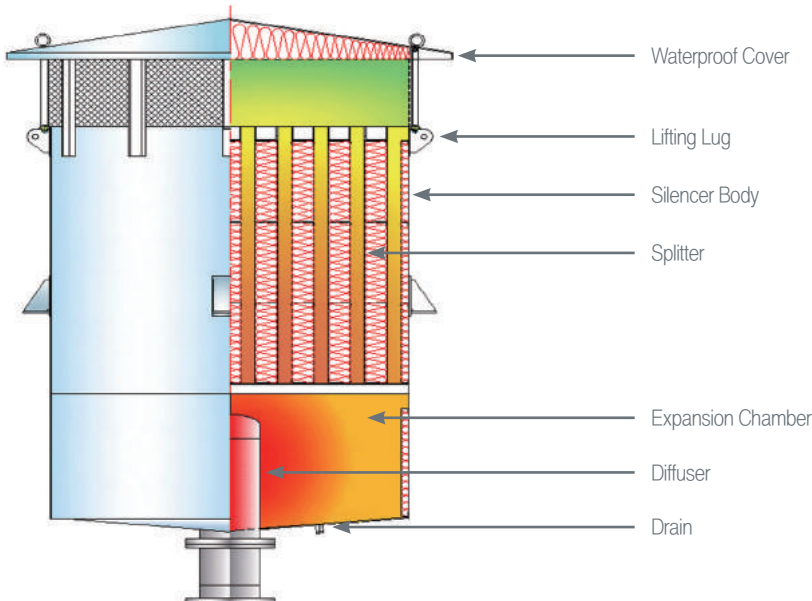

■ VENT SILENCER



SPR Soundproof Room



■ Soundproof Room

It is to make the noise-generating industrial facility into a room using sound absorbing/insulation panels in whole or in part. NSV plans the sound attenuation target in light of installation and surrounding conditions and designs, makes and installs the room to ensure performance.

■ Considerations in soundproof design

- Data of noise generated per frequency from the target facilities
- Location of the sound pick-up point and allowable noise level
- Ventilation and open-part soundproof depending on increase in indoor temperature
- Opening/closing plan and installation structure for maintenance
- Installation of door/window with the flow of human traffic in mind
- Location of electrical units, enclosing of penetration and drain

■ A Soundproof Room Structure Drawing

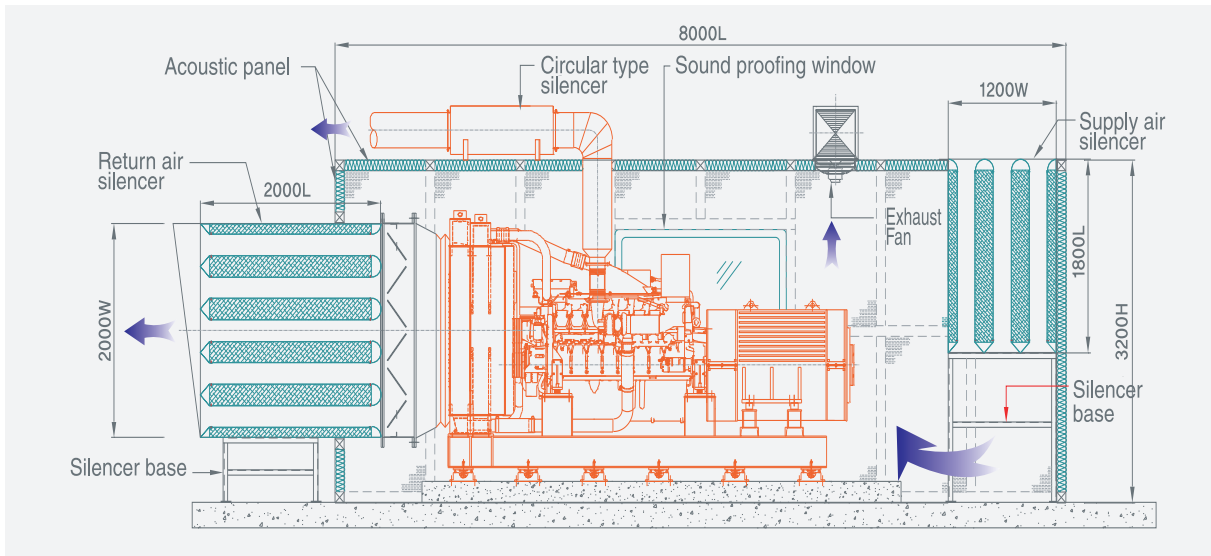

SPD Soundproof Door

■ Features

A soundproof door is made up of several heavy materials that have a relatively high aerial density stacked up. The door itself has a high transmission loss and is designed to have as little a gap with the frame as possible. It is always provided in a pair consisting of the doorframe and door. Plus, a robust door lock is used to make sure that the room is enclosed.



NSD-A STAINLESS soundproof door (single door)

Used for air conditioning rooms, machine rooms, soundproof rooms and audiovisual rooms



NBL-A BRONZE LEATHER soundproof door (double door)

Used for auditoriums, theaters, meeting rooms and schools



NSL-A STEEL LEATHER soundproof door (double door)

Used for recording rooms, studios and meeting rooms

■ Detailed drawing for soundproof door installation

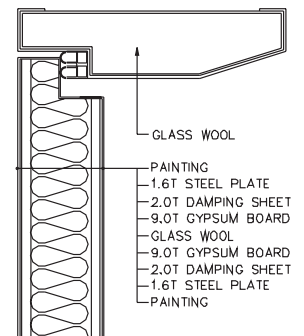
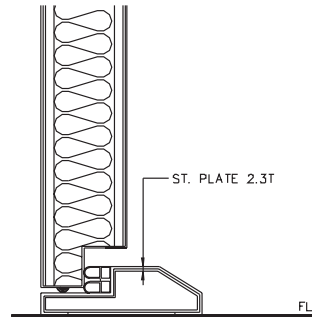
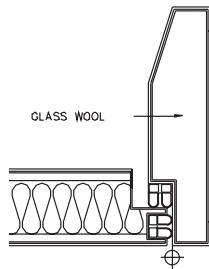
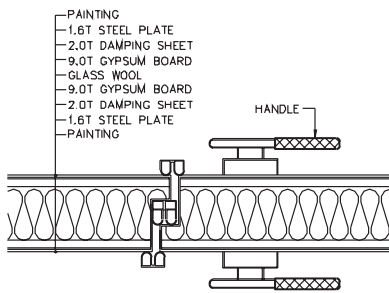

SW Soundproof Window

It is installed in a place where soundproofing is required, in a way that people outside can see inside. It is usually double/triple/quadruple glazed. Sound attenuation: 30~45dB



NAW-3P ACOUSTIC WINDOW (triple glazed)

Used for studios, theaters, soundproof rooms and audiovisual rooms

FRAME finishing material is optional.



NAW-4P ACOUSTIC WINDOW (quad-glazed)

Used for special industries and TEST CELL

NDP Damping Sheets



■ Features

It is a viscoelastic material having a relatively high damping loss. It converts vibrational energy into thermal energy through internal viscous damping and friction. It is used to reduce the sound energy generated when a panel shakes due to vibration, resonance amplitude and vibration on joint parts.

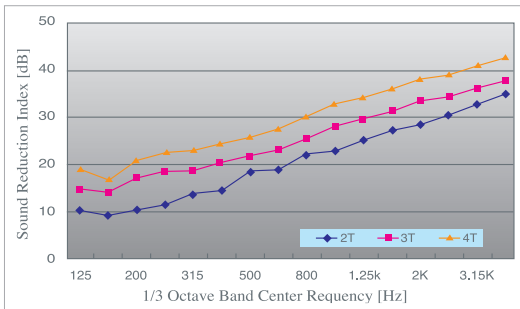

■ Dimension(size 1000x1000mm)

| Type | Material | Thickness | Usage | Features |
|-------|---------------------------------|-----------|---------------------------|---|
| NDP-F | EVA+Film+Asphalt+Other Compound | 2.0~4.0mm | AHU Room, Mechanical Room | Good for Sound Insulation and Dust Proofing |

(NOTE) The mentioned size and scale can be altered to improve the quality performance and capacity of the product without any notice.

NDT Damping Tape

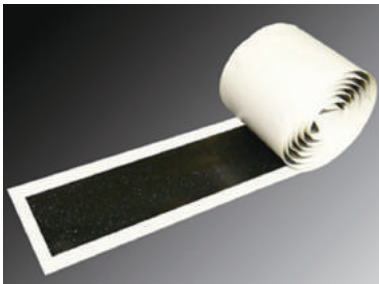

■ Features

The main material is butyl synthetic rubber, which is a tape-shaped material excellent in vibration control. It improves the loss factor from noise and vibration sources to reduce problematic vibration. With the mix of highly-functional additives and high molecules having excellent weather-resistance and viscosity, it offers excellent soundproof effects.

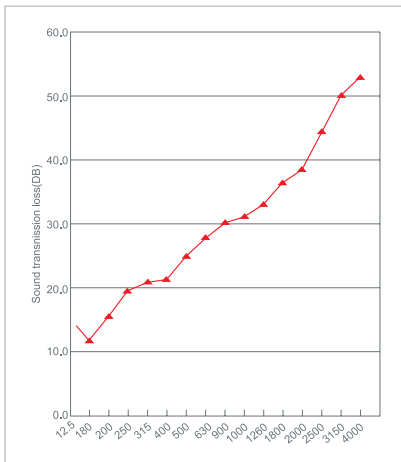

■ Specification

| | |
|-----------|---------|
| Type | NDT |
| Material | BUTYL |
| Thickness | 3.2mm |
| Width | 20~80mm |
| Length | 10m |

(NOTE) The mentioned size and scale can be altered to improve the quality performance and capacity of the product without any notice.

AR Anechoic Room



It is a room designed to absorb most of the noise because it has great sound absorbing power. It has the feature of reducing 6dB noise level when the distance is doubled in free space (like sound attenuation in distance).

$$SPL = PWL + 10 \log \left(\frac{1}{4\pi r^2} \right)$$

Floors, ceilings and walls are all soundproofed, but wires on the floor are connected both lengthwise and breadthwise to reduce the acoustic reflex. In addition, a soundproof revolving room, or door that opens inward is used as the entrance door.

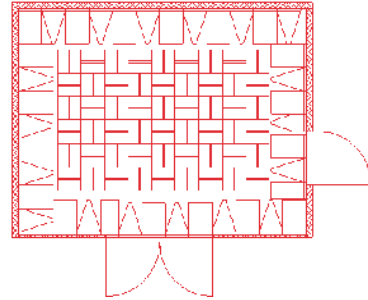

■ Purpose and application

1. Identification of the noise level distribution of sound source
2. Measurement of PWL (acoustic power level) of sound source
3. Research of the acoustic properties of equipment, machines and parts
4. Sound-proofing feature
5. Acoustic facilities calibration

ER Reverberation Room



Because it has very little sound attenuation power, it is designed in a non-rectangular form to obtain diffuse sound fielded through acoustic reflex. In this room, almost the same level of sound is absorbed from anywhere around the room regardless of the distance from source of the sound.

$$SPL = PWL + 10 \log \left(\frac{4}{R} \right)$$

In some cases, two eco rooms are arranged to form an opening, and either construction material or a wall is attached to the opening for the transmission loss of sound. Sometimes, two eco rooms are stacked up to form an opening in between and the floor material is attached to test crashing sound.



■ Purpose and application

1. Transmission loss of construction material
2. Measurement and analysis of crashing sound on the floor
3. Measurement of sound absorbing coefficient

PO-MAT[®] Polyurethane Mat



■ Features

Microcellular Polyurethane Mat is elastic and capable of supporting a wide range of dynamic loads owing to micro-sized air gap inside. In particular, the thickness of the Floating Slab can be reduced as the load is distributed evenly over the surface. Because Mat itself maintains elasticity and isolates noise, extra Floating Slab lifting is not required. It comes in different colors depending on its density, which makes it easier to select, handle and install.

■ Specification

| Model | A25 | B25 | C25 | D25 | E25 | F25 | G25 | H25 |
|--------------------------------|-------------------|----------|----------|----------|----------|----------|----------|----------|
| Color | Green | Yellow | Blue | Pink | Brown | Red | Gray | Black |
| Thickness | 25T | | | | | | | |
| Density(kg/m ³) | 150±20% | 220±20% | 300±20% | 400±20% | 500±20% | 600±20% | 800±20% | 1000±20% |
| Rated Load(N/mm ²) | 0.01±20% | 0.03±20% | 0.05±20% | 0.10±20% | 0.15±20% | 0.40±20% | 1.50±20% | 5.00±20% |
| Rated Def. (mm) | 6.0 | | | | | | 3.0 | 1.5 |
| Size | 1000mmX1000mmX25T | | | | | | | |

(NOTE) The mentioned size and scale can be altered to improve the quality performance and capacity of the product without any notice.

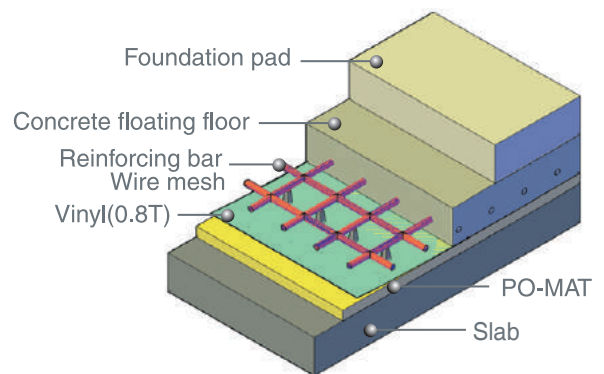

■ PO-MAT Durability Test Data

| PO-MAT Model | Density (kg/m ³) | Lifetime (room temperature:20°C) | Activation Energy (kJ/mol) |
|--------------|------------------------------|----------------------------------|----------------------------|
| A-25 | 150 | 612Year | 200 |
| B-25 | 220 | 630Year | 207 |
| C-25 | 300 | 644Year | 206 |
| D-25 | 400 | 652Year | 185 |
| E-25 | 500 | 660Year | 219 |
| F-25 | 600 | 675Year | 193 |

■ Test Equipment(DMA 2980, TA Instrument)



- The data above is the result of the test performed upon request by the Department of Chemical Engineering at Hanyang University. The test was conducted to predict durability using Time Temperature Superposition (TTS) and observe stress-relaxation under constant compression strain.

★ TTS : The higher the temperature, the less time is required for stress-relaxation; this principle is used to predict changes in mechanical behavior over time at a given temperature when temperature is changed within a measurable time range.

PO-MAT[®] Polyurethane Mat

■ The PO-MAT Durability Test Resulting Graph

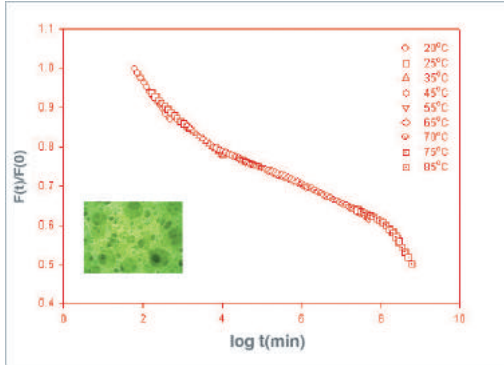

- Sample A : Green
- Density : 150Kg/m³
- Durability : Durability 612yrs(20)

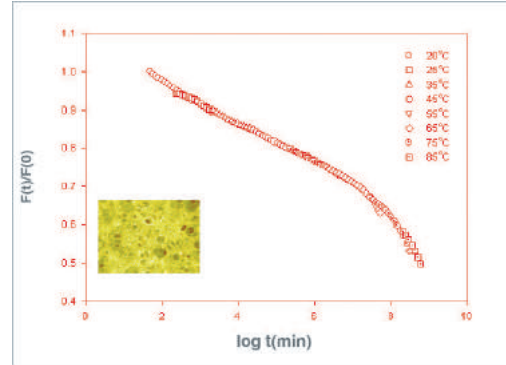

- Sample B : Yellow
- Density : 220Kg/m³
- Durability : Durability 630yrs(20)

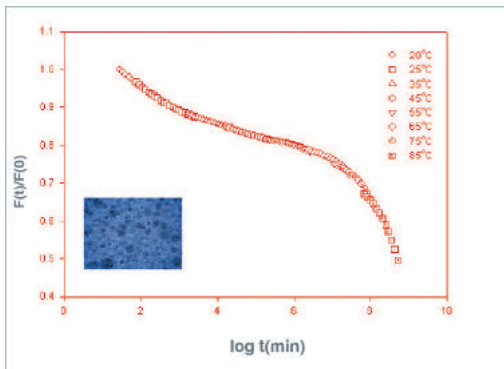

- Sample C : Blue
- Density : 300Kg/m³
- Durability : Durability 644yrs(20)

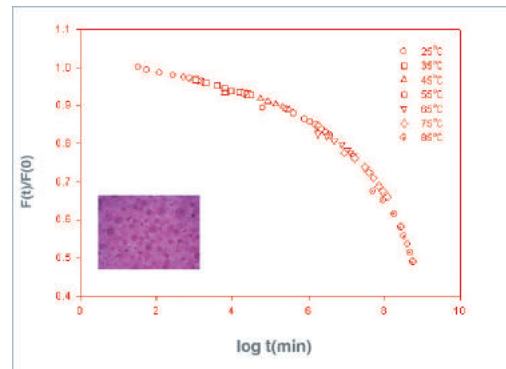

- Sample D : Pink
- Density : 400Kg/m³
- Durability : Durability 652yrs(20)

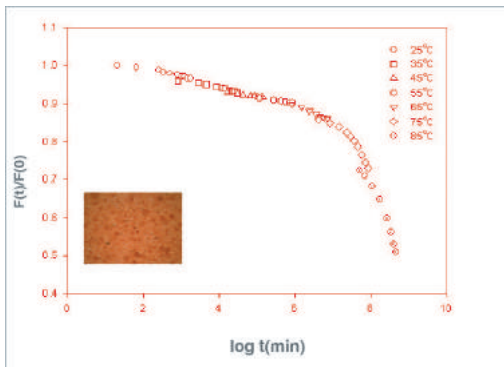

- Sample E : Brown
- Density : 500Kg/m³
- Durability : Durability 660yrs(20)

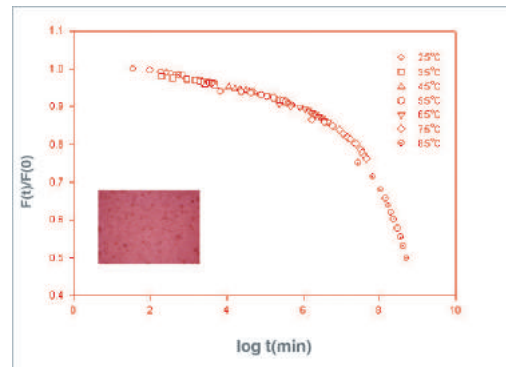

- Sample F : Red
- Density : 600Kg/m³
- Durability : Durability 675yrs(20)

PO-MAT[®] Polyurethane Mat

PO-MAT Installation Order

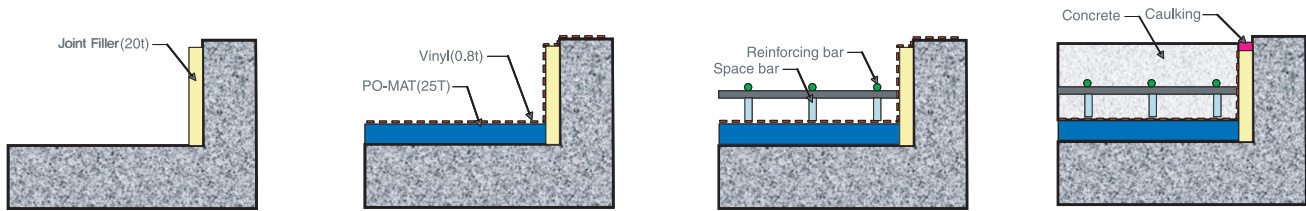

1. Clean the floor where the PO MAT is to be installed, keep level and install the MAT when the floor is dried.
2. Cover drain, vertical pipes, ducts and electric line-passing parts with joint filler and/or heat insulating materials.
3. Attach joint filler on surrounding walls and pillars that come in contact with double-bottomed slab.
4. Install the PO-MAT according to the approved drawing, in a way that manufacturer's name and model comes on top.
5. Install 2 layers of 0.08 mm-thick polyethylene (PE) plastic on top of the PO-MAT and attach using the OPP adhesive tape.
6. Install a wire mesh or steel reinforcement as shown in the approved drawing. Be cautious not to damage the plastic.
7. Place concrete and then leave it for curing. (According to the construction specification standard)
8. Then, do the caulking with 10mm-thick sealant.

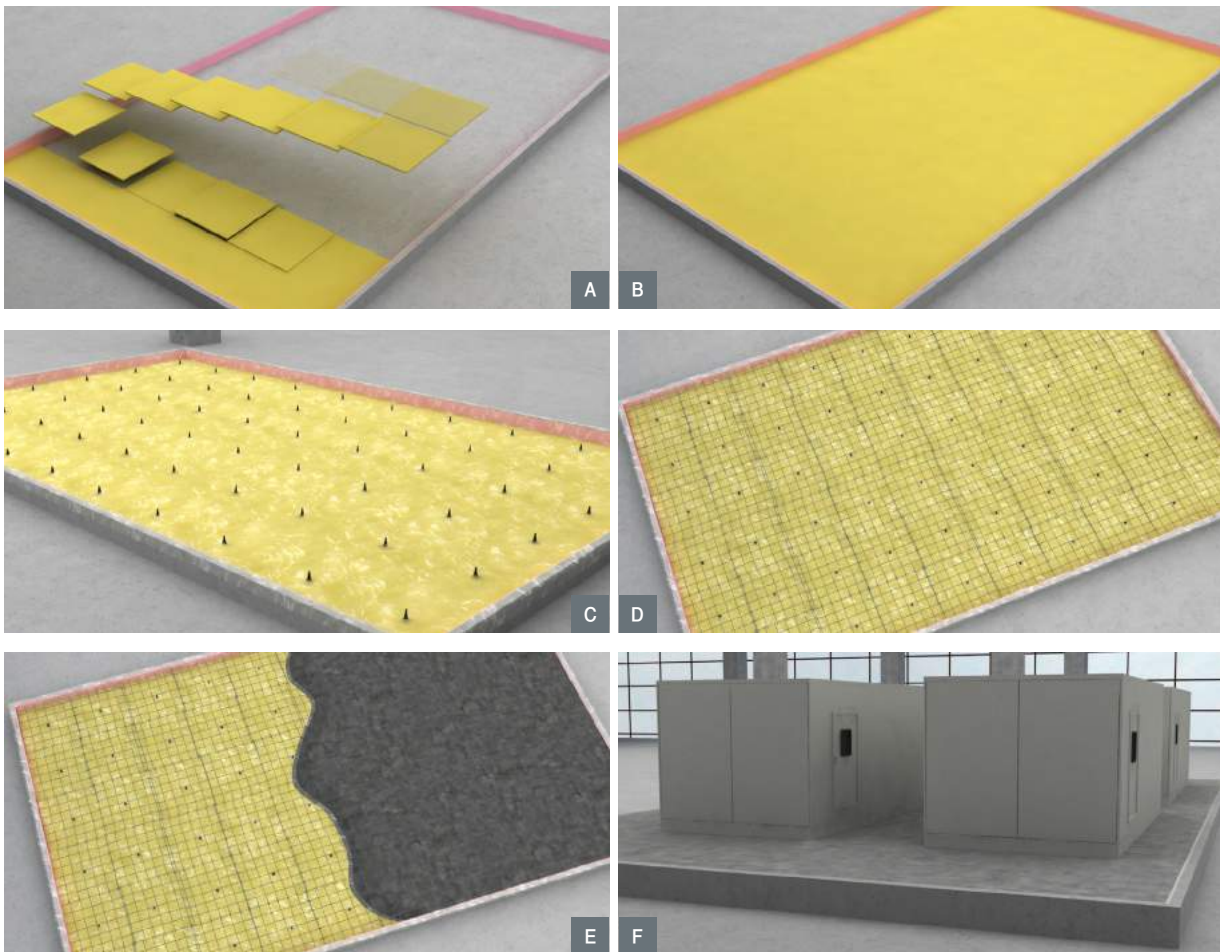

PO-MAT[®] Polyurethane Mat

PO-MAT Construction Method

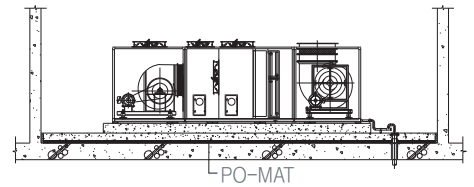
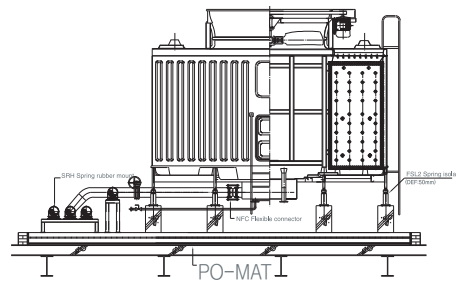
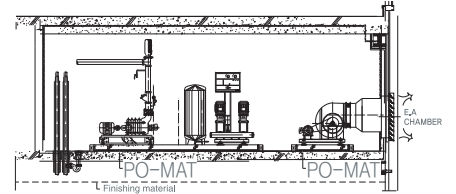
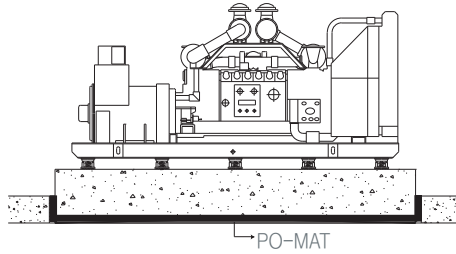
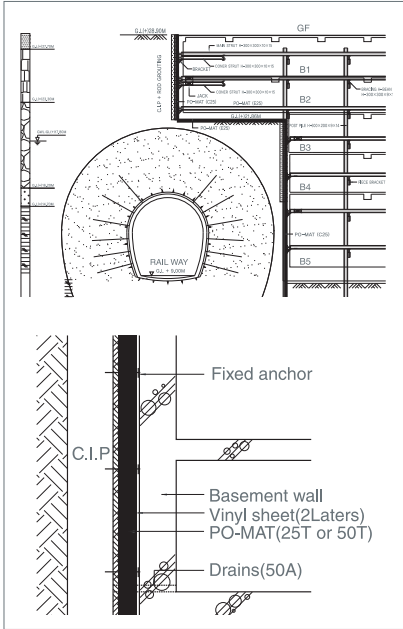

25T Test Data

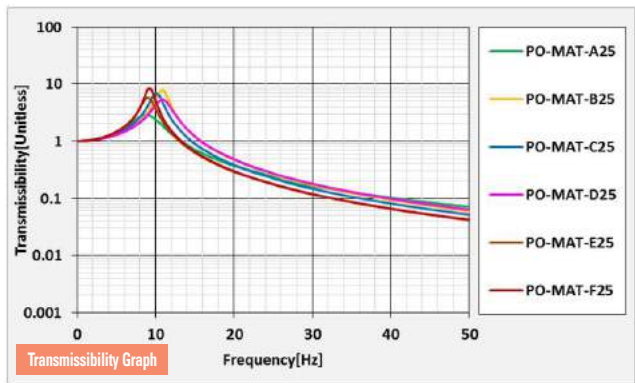
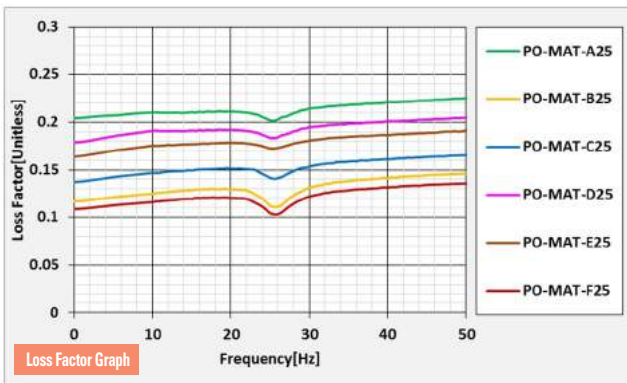
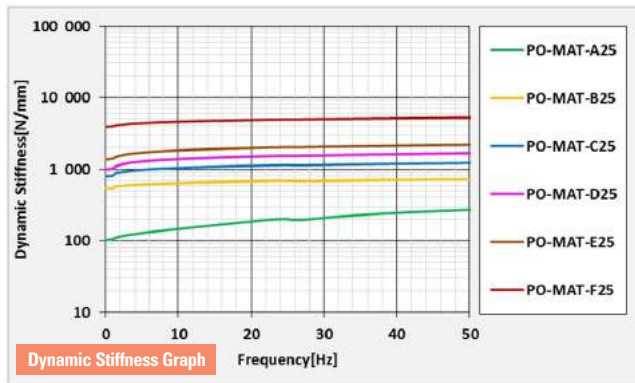
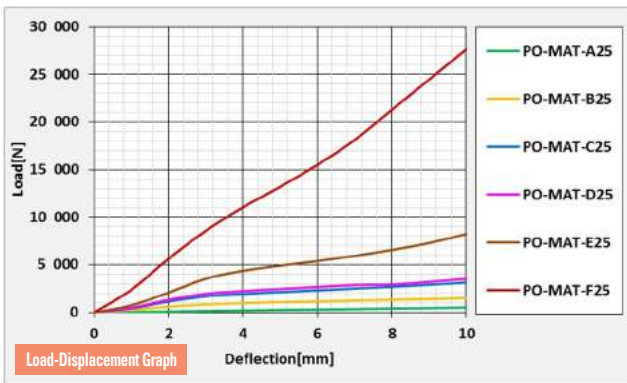

PO-MAT[®] Polyurethane Mat

■ 50T Test Data

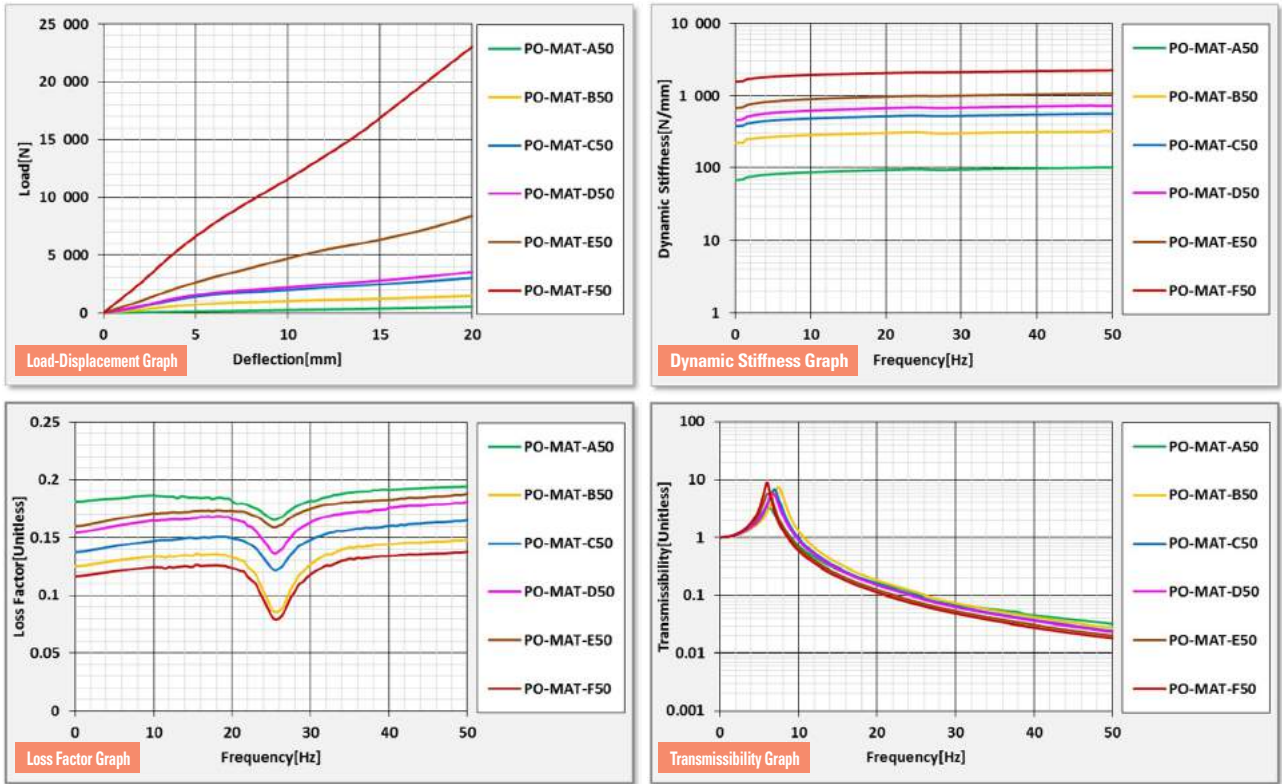

■ Explanation(Commonness)

1. Vibration Transmissibility(T_r)

Vibration Transmissibility is the amplitude ratio of Output to Input.

$$T_r = \frac{\text{Output Amplitude}}{\text{Input Amplitude}} = \frac{1}{\sqrt{(1-\eta^2)^2}} \cdot \eta = \frac{\text{Disturbing Frequency of the equipment}}{\text{Natural Frequency of the Isolator (Damping}(c) = 0)}$$

2. Natural Frequency(F_n) of Vibration Isolation System

The mass and spring stiffness dictate a natural frequency of the system.

$$F_n = \frac{1}{2\pi} \sqrt{\frac{k}{m}}$$

3. Isolation Efficiency(E)

Isolation Efficiency in percent transmission is related to Vibration Transmissibility $E = 100(1 - T_r)$

ex) Disturbing Frequency of the equipment=100 Hz,

Natural Frequency of the isolator=10Hz

$$T_r = \sqrt{\left(\frac{1}{1-\eta^2}\right)^2} = \sqrt{\left(\frac{1}{1-\left(\frac{100}{10}\right)^2}\right)^2} = 0.101 \quad E = 100(1 - T_r) = 100(1-0.101)=99(\%)$$

4. Loss Factor(ζ)

① Loss Factor is the double damping ratio on natural frequency of Vibration Isolation System $\eta = 2 \times \zeta$ (Damping Ratio)

② The damping ratio is a dimensionless measure describing how oscillations in a system decay after a disturbance.

$$\zeta = \frac{\text{Actual Damping}}{\text{Critical Damping}}$$

5. Dynamic Stiffness(k_d)

The dynamic stiffness is the frequency dependant ratio between a dynamic force and the resulting dynamic displacement.

$$k_d = \frac{\text{Force(Frequency)}}{\text{Vibration Response}}$$

HD-MAT High-Damping Mat



■ Features

It is a highly-molecular copolymer formed through the foaming of HSBR (Hydrogenated SBR) blended with EVA (Ethylene Vinyl Acetate). Because it has adequate elasticity compared to the conventional foam and excellent damping properties against external exciting force and impulsive load, it can be converted into a static state in a short space of time.

■ Specification

| Model | A25 | A50 | B25 | B50 | C25 | C50 |
|---|--|-----------|-------------|-----------|-------------|-----------|
| Color | Orange | | Sky Blue | | Purple | |
| Thickness | 25 | 50 | 25 | 50 | 25 | 50 |
| Density(kg/m ³) | 100±20% | | 150±20% | | 200±20% | |
| Tensile Strength(MPa) | Over 1.3 | | Over 1.8 | | Over 2.0 | |
| Coefficient of Extension(%) | Over 220 | | Over 220 | | Over 220 | |
| Rated Load(N/mm ²) | 0.08±20% | | 0.17±20% | | 0.20±20% | |
| Rated Def.(mm) | 8 | 16 | 8 | 16 | 8 | 16 |
| Natural Freq.(Hz) | Under 12 | Under 8 | Under 12 | Under 8 | Under 12 | Under 8 |
| Rebound Resilience(%) | Under 25 | | Under 25 | | Under 25 | |
| Loss Factor(tanδ) | Over 0.3 | Over 0.27 | Over 0.3 | Over 0.27 | Over 0.3 | Over 0.27 |
| Dynamic Modulus of Elasticity(N/mm ²) | Under 1.6 | Under 2.0 | Under 1.6 | Under 2.0 | Under 1.6 | Under 2.0 |
| Compression Set ((23±2)°C, 22h) | Under 5.0 | | Under 5.0 | | Under 5.0 | |
| Water Absorption Ratio (g/cm ²) | Under 0.005 | | Under 0.005 | | Under 0.005 | |
| Size(W x H x T) | 1000mmX1000mmX25mm, 1000mmX1000mmX50mm | | | | | |

(NOTE) The mentioned size and scale can be altered to improve the quality performance and capacity of the product without any notice.

■ Installation features

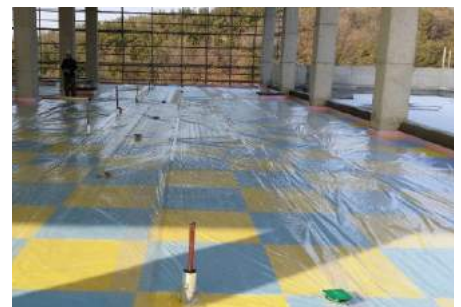
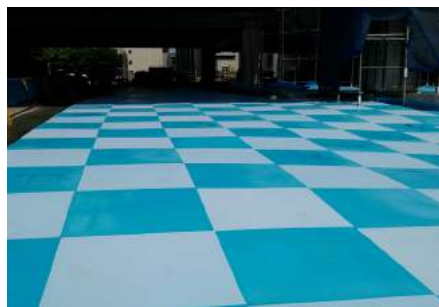

HD-MAT High-Damping Mat

■ 25T Test Data

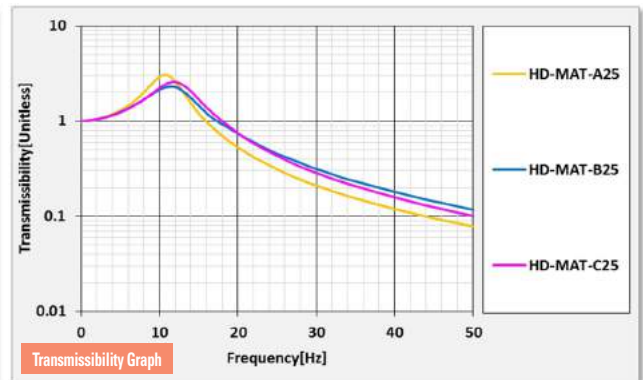
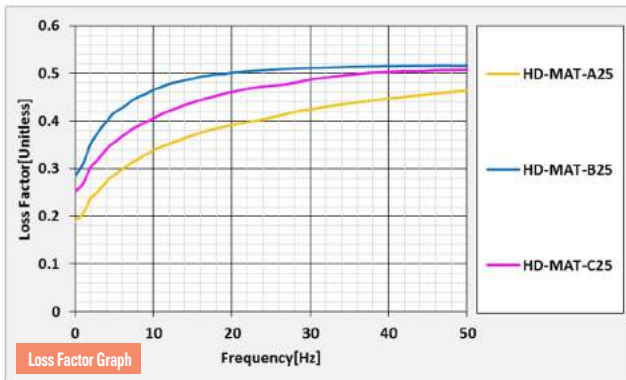
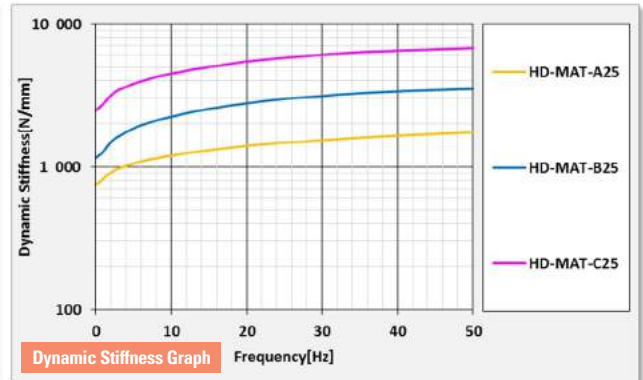
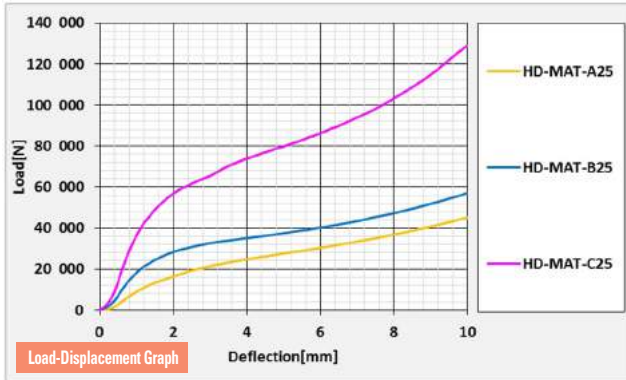

■ 50T Test Data

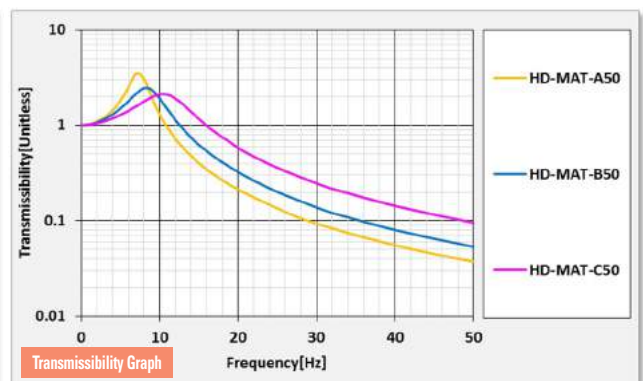
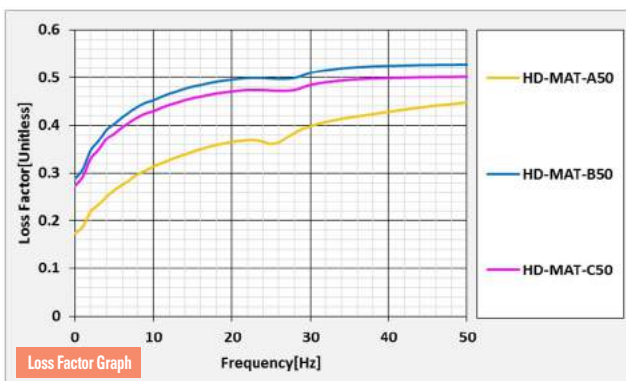
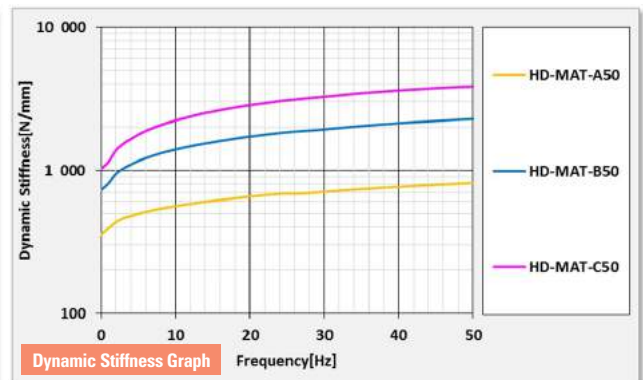
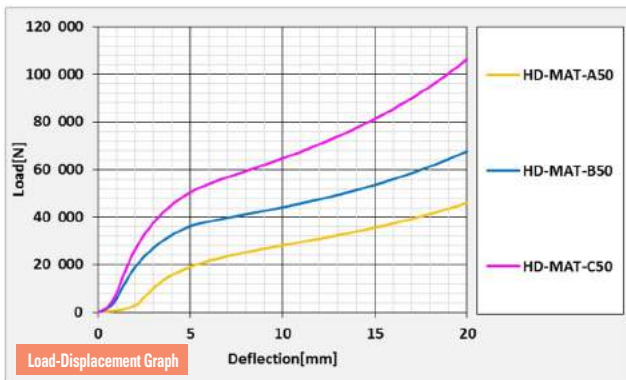

HE-MAT High-Elasticity Mat

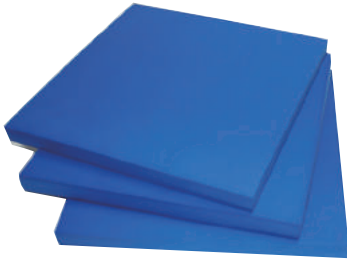

■ Features

It is a highly-molecular copolymer formed through the foaming of high-elastic ethylene olefin blended with styrene copolymer. It has a higher elasticity than that of common foam and outstanding glutinous properties. Plus, it can be used as an alternative to the anti-vibration system for the floating floor of structure under concentrated load/distributed load and anti-vibration rubber material used for construction facilities as it can control the dynamic range of compressive load depending on the specific gravity and has a good resistance to compressive deformation.

■ Specification

| Model | HE-MAT 25 | HE-MAT 50 |
|---|-----------------------|-----------|
| Color | Blue | |
| Thickness | 25 | 50 |
| Density(kg/m ³) | 270±20% | |
| Tensile Strength(MPa) | Over 1.3 | |
| Coefficient of Extension(%) | Over 200 | |
| Rated Load(N/mm ²) | 0.11±20% | |
| Rated Def.(mm) | 6 | 12 |
| Natural Freq.(Hz) | Under 10 | Under 8 |
| Rebound Resilience(%) | Over 80 | |
| Dynamic Modulus of Elasticity(N/mm ²) | Over 5 | Over 5 |
| Compression Set ((23±2)°C, 22h) | Under 3 | |
| Water Absorption Ratio(g/cm ³) | Under 0.003 | |
| Size(WxHxT) | 1000mm X 1000mm X 25T | |

(NOTE) The mentioned size and scale can be altered to improve the quality performance and capacity of the product without any notice.

■ HE-MAT Test Data

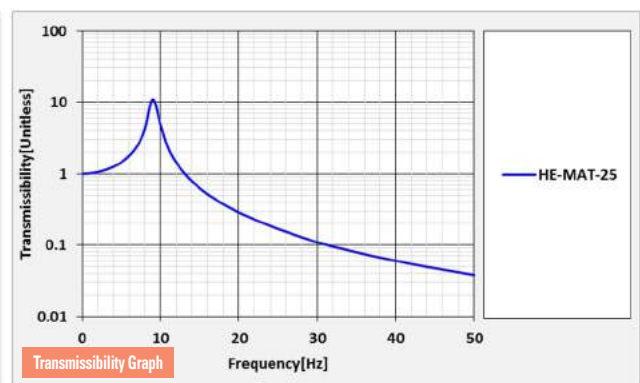
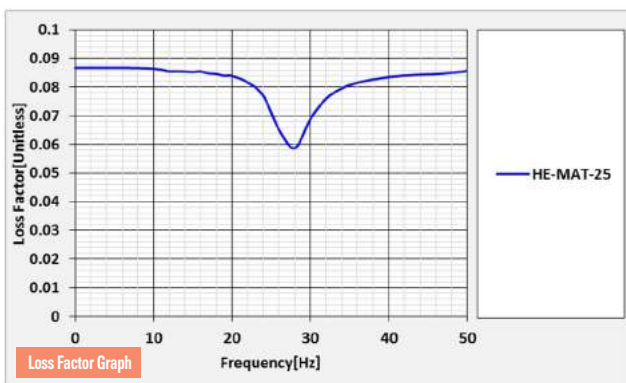
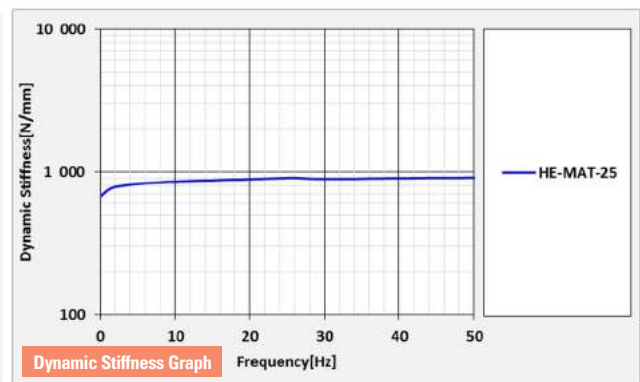

NP-MAT Neoprene Mat



■ Features

The NP-MAT is made of neoprene rubber (CR:Chloroprene Rubber) with excellent durability and relatively stable oil, heat and chemical resistance that is foamed and shaped with high density. The close-cell structure inside the mat helps absorb shock, vibration and noise without volumetric displacement.

■ Intended use

- Double bottom of air conditioning rooms and machine rooms
- Shock-absorbing material for machines
- For the isolation of buildings from a vibration-generating subway
- Base vibration and noise control in a special area
- For the floor of sports facilities

■ Physical properties

- Damp proof property (absorption rate : less than 0.5g/cm²)
- Insulation : Thermal conductivity (0.036W/m.Kat20°C)
- No environment pollutant contained and harmless to human
- Non-combustible

■ Dimension & Selection Guide

| Model | Color | Density(kg/m ³) | Rated Def.(mm) | Coefficient of Extension(%) | Size(mm) |
|--------|-------|-----------------------------|----------------|-----------------------------|--------------|
| NP-B25 | Black | 200±20% | 8 | Over 250 | 1000X1000X25 |
| NP-B50 | | | 16 | | 1000X1000X50 |
| NP-C25 | | 300±20% | 8 | | 1000X1000X25 |
| NP-C50 | | | 16 | | 1000X1000X50 |

(NOTE) The mentioned size and scale can be altered to improve the quality performance and capacity of the product without any notice.

EP-MAT EVA Mat



■ Features

EVA (Ethylene Vinyl Acetate) resin is copolymer produced through the polymerization of ethylene monomer and VAM (Vinyl Acetate Monomer) in autoclave reactors, which is used to produce LDPE (Low Density Polyethylene) with as much VAM as VA in content. Because it has excellent elasticity and flexibility, it is suitable as a buffer to alleviate the transfer of structure-borne shock and vibration through neighboring rooms on lower and upper floors. It is mostly used as the base pad for air conditioning rooms and machine rooms.

■ Dimension & Selection Guide

| Model | Measure | EP-10 | EP-20 | EP-25 | EP-30 | EP-50 |
|--------------------------------|-------------------|---|-------|-------|-------|-------|
| Thickness | mm | 10 | 20 | 25 | 30 | 50 |
| Density | Kg/m ³ | 100±20% | | | | |
| Tensile Strength | MPa | Over 1 | | | | |
| Coefficient of Extension | % | Over 85 | | | | |
| Hardness of spring | - | Over 30 | | | | |
| Rebound Resilience | % | Over 25 | | | | |
| Compression Set((23±2)°C, 22h) | % | Under 5 | | | | |
| Size (W x H x t) | mm | 900mm x 1800mm x 10mm, 20mm, 25mm, 30mm, 50mm | | | | |

(NOTE) The mentioned size and scale can be altered to improve the quality performance and capacity of the product without any notice.

JUM-10000/20000/30000/40000 Jack Up Mount

■ Features

The jack-up system absorbs and insulates noise, impulsive vibration, as well as impulsive noise generated in problematic areas, such as air conditioning rooms, machine rooms and bowling alleys. It has at least a 50 mm-deep air layer and a 100mm-thick ferroconcrete slab using the neoprene mount on top of the slab. It increases transmission loss of noise in the double slab (floating floor) and prevents the transfer of vibration and primary structure-borne noise in the neoprene mount. The jack screw bolt should be on the top to lift the slab after installation and the support fixture should be on both sides for the distribution of steel reinforcements. Plus, the neoprene mount must have a steel plate within in order to handle a dynamic load.

JUM-10000 (Deflection : 17mm)

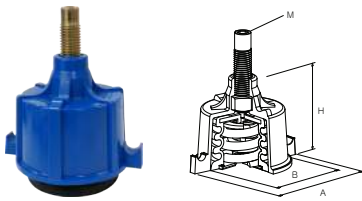

■ Dimension & Selection Guide

| Model | Capacity (kgf) | Deflection (mm) | Hardness (Hs) | Dimension | | | | Others | |
|-----------|----------------|-----------------|---------------|-----------|----|-----|-----|-------------|--------------------|
| | | | | A | B | H | M | Air Gap(mm) | Slab Thickness(mm) |
| JUM-10200 | 200 | 17 | 65±5 | 130 | 94 | 100 | M20 | 50~100 | 100~150 |
| JUM-10300 | 300 | | | | | | | | |
| JUM-10400 | 400 | | | | | | | | |
| JUM-10500 | 500 | | | | | | | | |
| JUM-10600 | 600 | | | | | | | | |
| JUM-10700 | 700 | | | | | | | | |
| JUM-10800 | 800 | | | | | | | | |

(NOTE) The mentioned size and scale can be altered to improve the quality performance and capacity of the product without any notice.

JUM-20000 (Deflection : 8mm)

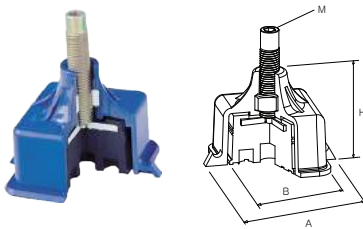

■ Dimension & Selection Guide

| Model | Capacity (kgf) | Deflection (mm) | Hardness (Hs) | Dimension | | | | Others | |
|-----------|----------------|-----------------|---------------|-----------|----|-----|-----|-------------|--------------------|
| | | | | A | B | H | M | Air Gap(mm) | Slab Thickness(mm) |
| JUM-20200 | 200 | 8 | 65±5 | 136 | 86 | 100 | M20 | 50~100 | 100~150 |
| JUM-20300 | 300 | | | | | | | | |
| JUM-20400 | 400 | | | | | | | | |
| JUM-20500 | 500 | | | | | | | | |
| JUM-20650 | 650 | | | | | | | | |
| JUM-20800 | 800 | | | | | | | | |

(NOTE) The mentioned size and scale can be altered to improve the quality performance and capacity of the product without any notice.

JUM-30000 (Deflection : 8mm)

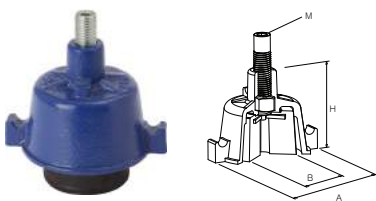

■ Dimension & Selection Guide

| Model | Capacity (kgf) | Deflection (mm) | Hardness (Hs) | Dimension | | | | Others | |
|-----------|----------------|-----------------|---------------|-----------|-----|-----|-----|-------------|--------------------|
| | | | | A | B | H | M | Air Gap(mm) | Slab Thickness(mm) |
| JUM-30200 | 200 | 8 | 65±5 | 154 | 116 | 100 | M20 | 50~100 | 100~150 |
| JUM-30300 | 300 | | | | | | | | |
| JUM-30500 | 500 | | | | | | | | |
| JUM-30650 | 650 | | | | | | | | |
| JUM-30800 | 800 | | | | | | | | |

(NOTE) The mentioned size and scale can be altered to improve the quality performance and capacity of the product without any notice.

JUM-40000 (Deflection : 50mm)

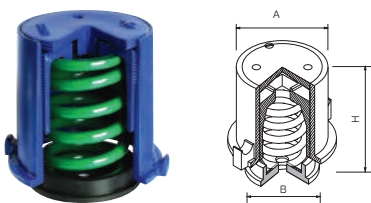

■ Features

It is mostly applied when vibration is a bigger problem than the noise (for example, air conditioning rooms and machine rooms where the vibration frequency is less than 20Hz or the vibration is less than 30Hz with broad amplitude is generated). When the spring jack up system is used to form the double bottom, it is best to maintain the natural frequency of the whole system between 3.6Hz and 4.0Hz using an anti-vibration spring mount with a static deflection of 20~50mm. At this point, the diameter of the spring should be about 80% of the spring height under static loading. (With a reserve more than 50% of the static load)

■ Dimension & Selection Guide

| Model | Color | Capacity(kgf) | Deflection(mm) | Dimension | | | Others | |
|-----------|--------|---------------|----------------|-----------|----|-----|-------------|--------------------|
| | | | | A | B | H | Air Gap(mm) | Slab Thickness(mm) |
| JUM-40200 | White | 200 | 50 | 180 | 95 | 100 | 50 | 150 |
| JUM-40300 | Orange | 300 | | | | | | |
| JUM-40400 | Pink | 400 | | | | | | |
| JUM-40500 | Green | 500 | | | | | | |
| JUM-40600 | Blue | 600 | | | | | | |
| JUM-40750 | Black | 750 | | | | | | |

(NOTE) The mentioned size and scale can be altered to improve the quality performance and capacity of the product without any notice.

JUM-10000/20000/30000/40000 Jack Up Mount

Jack-up system before/after lifting

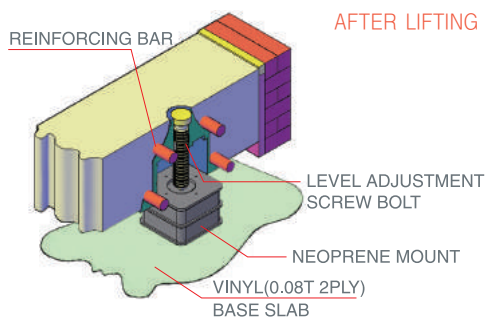
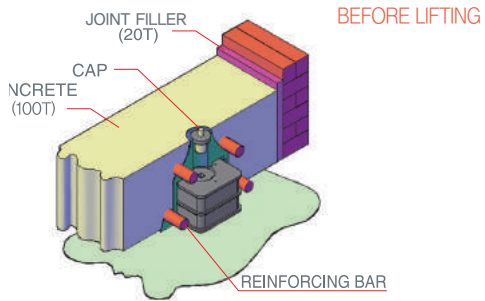

Jack-up system Installation Order

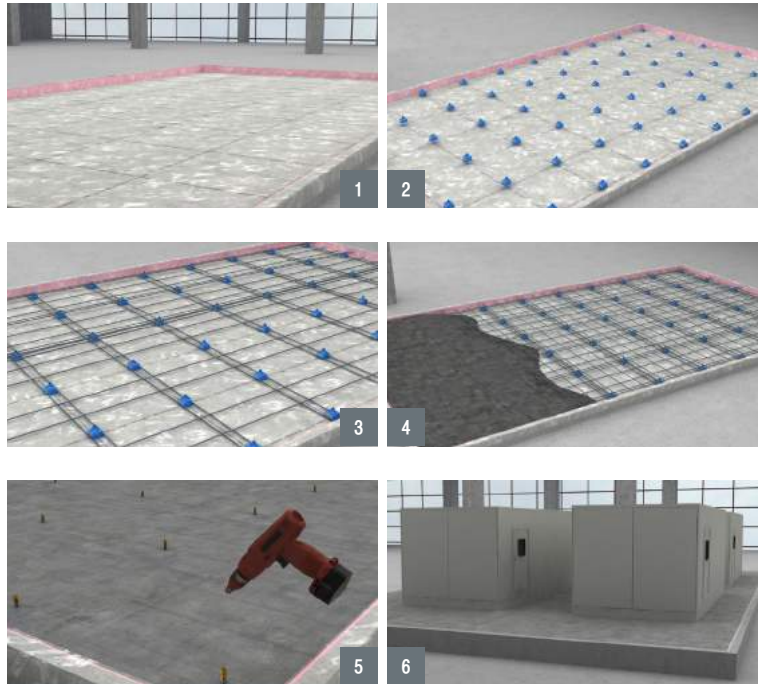

JUM-10000 Test Data

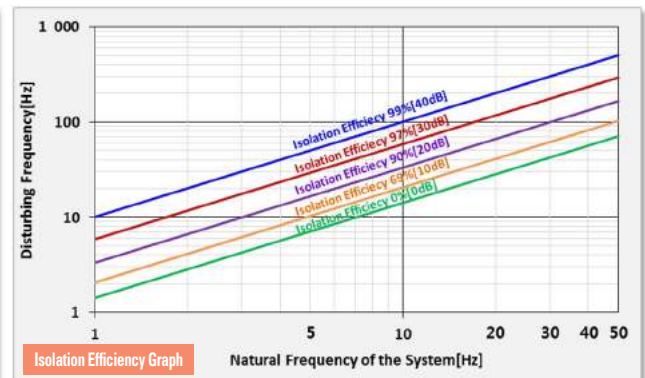
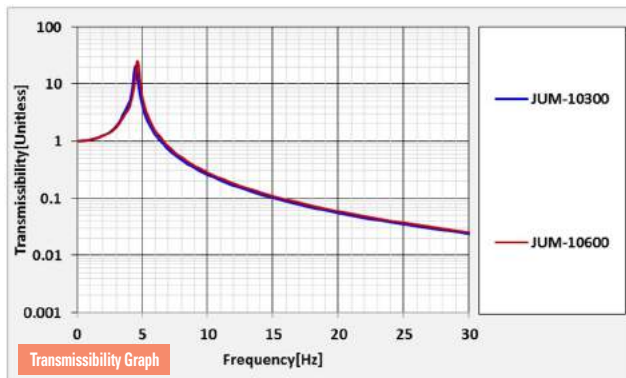
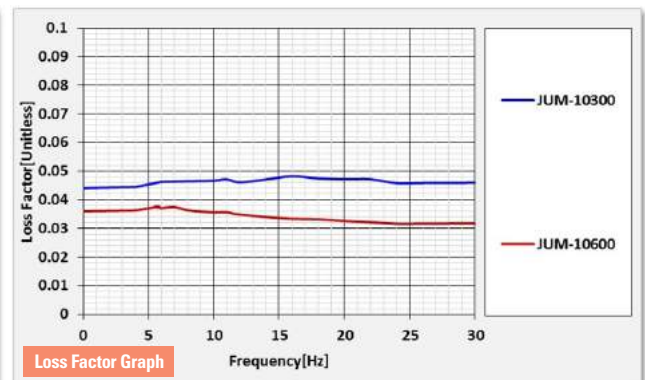
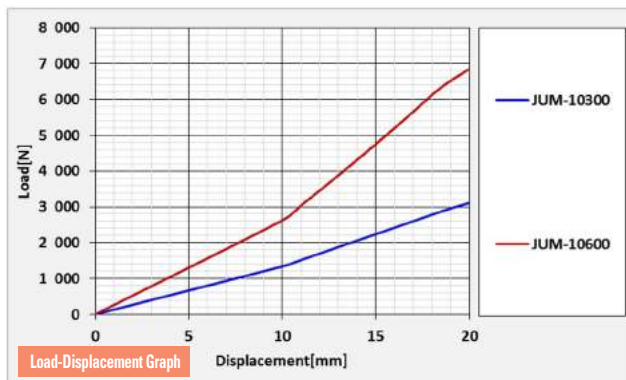

JUM-10000/20000/30000/40000 Jack Up Mount

■ JUM-20000 Test Data

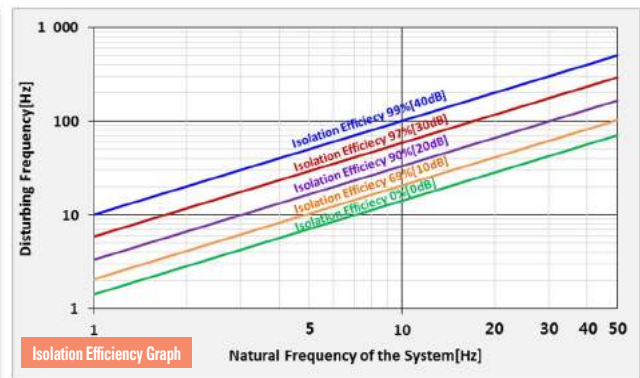
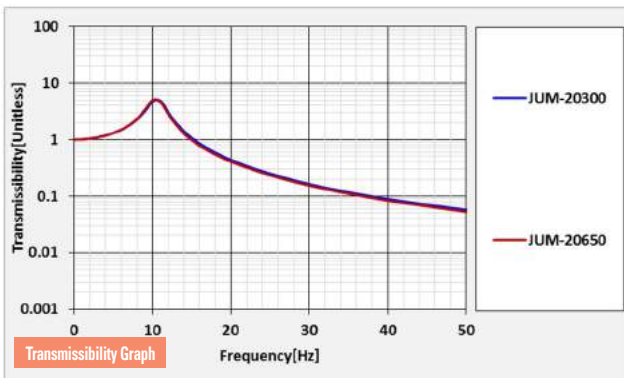
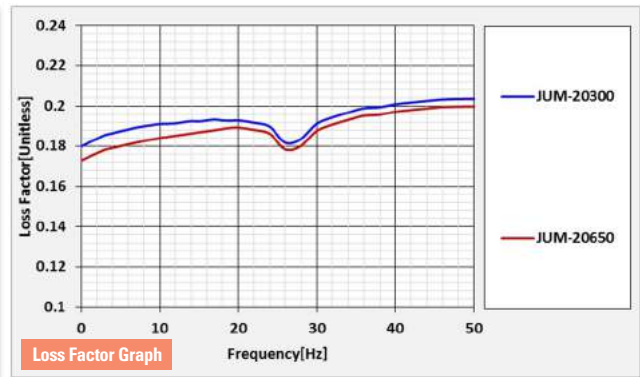
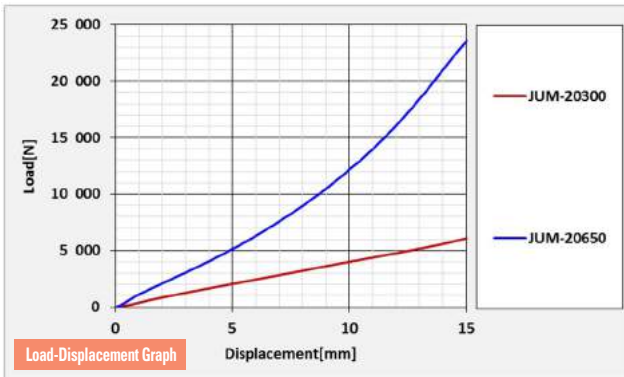

■ JUM-30000 Test Data

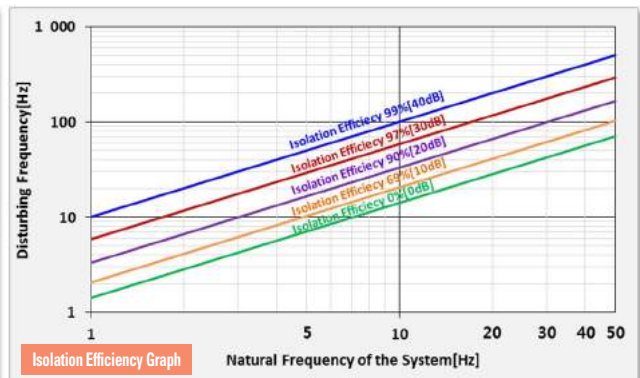
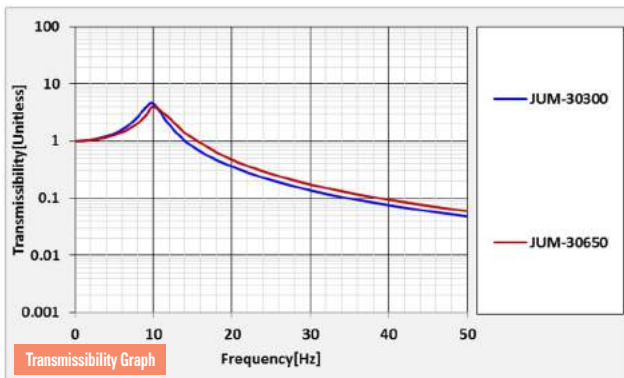
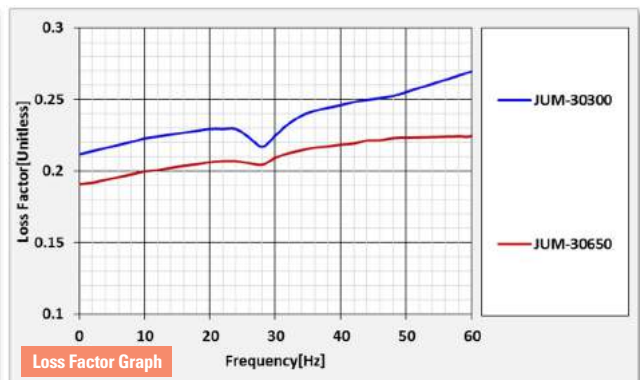
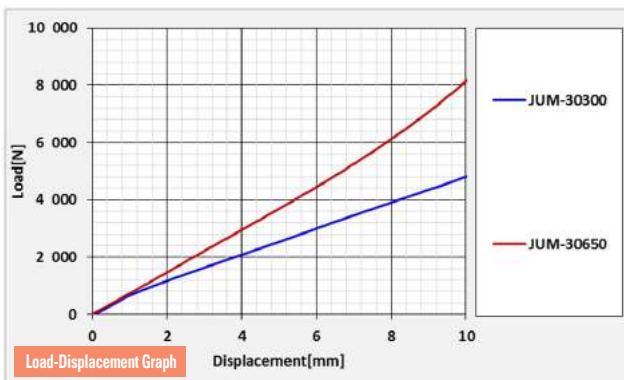

JUM-10000/20000/30000/40000 Jack Up Mount

JUM-40000 Test Data

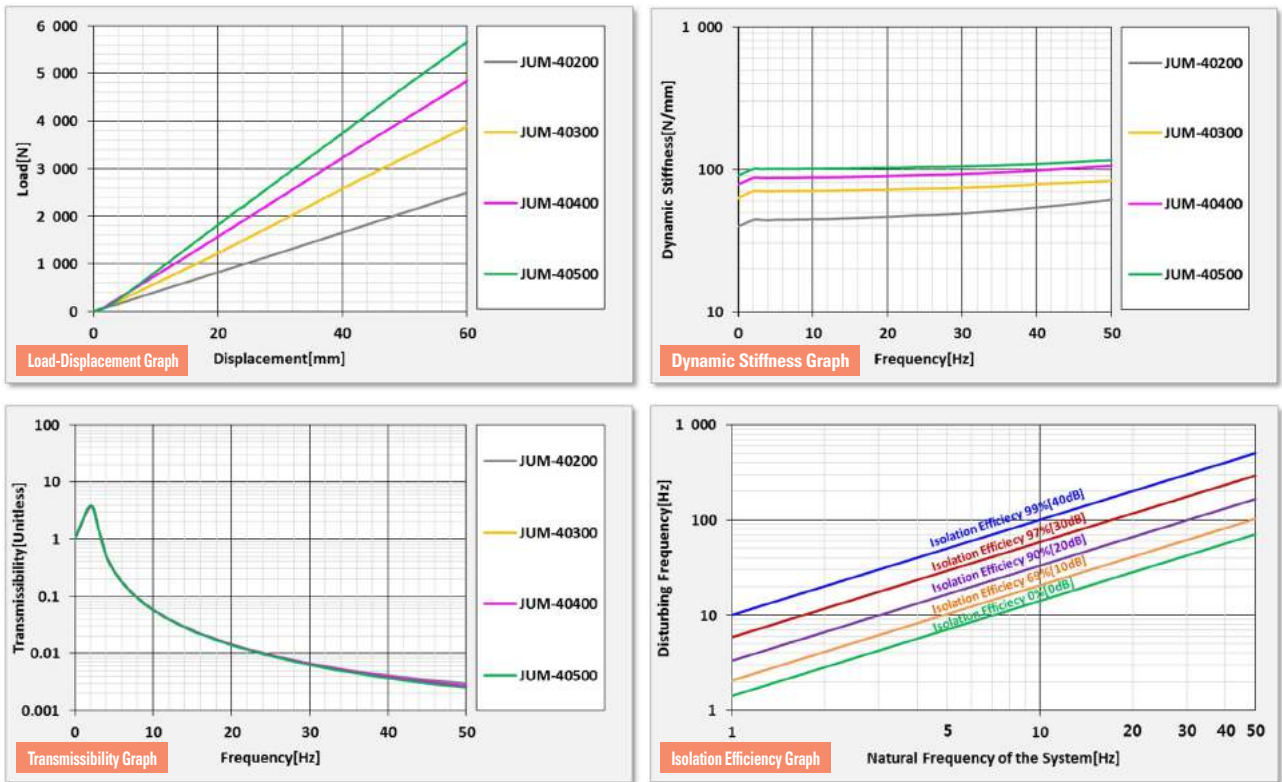

Explanation(Commonness)

1. Vibration Transmissibility(T_r)

Vibration Transmissibility is the amplitude ratio of Output to Input.

$$T_r = \frac{\text{Output Amplitude}}{\text{Input Amplitude}} = \sqrt{\left(\frac{1}{1-\eta^2}\right)^2}, \eta = \frac{\text{Disturbing Frequency of the equipment}}{\text{Natural Frequency of the Isolator (Damping}(c) = 0)}$$

2. Natural Frequency(F_n) of Vibration Isolation System

The mass and spring stiffness dictate a natural frequency of the system.

$$F_n = \frac{1}{2\pi} \sqrt{\frac{k}{m}}$$

3. Isolation Efficiency(E)

Isolation Efficiency in percent transmission is related to Vibration Transmissibility $E = 100(1 - T_r)$

ex) Disturbing Frequency of the equipment=100 Hz,

Natural Frequency of the isolator=10Hz

$$T_r = \sqrt{\left(\frac{1}{1-\eta^2}\right)^2} = \sqrt{\left(\frac{1}{1-\left(\frac{100}{10}\right)^2}\right)^2} = 0.101 \quad E = 100(1 - T_r) = 100(1-0.101)=99(\%)$$

4. Loss Factor(ζ)

① Loss Factor is the double damping ratio on natural frequency of Vibration Isolation System $\eta = 2 \times \zeta$ (Damping Ratio)

② The damping ratio is a dimensionless measure describing how oscillations in a system decay after a disturbance.

$$\zeta = \frac{\text{Actual Damping}}{\text{Critical Damping}}$$

5. Dynamic Stiffness(k_d)

The dynamic stiffness is the frequency dependant ratio between a dynamic force and the resulting dynamic displacement.

$$k_d = \frac{\text{Force(Frequency)}}{\text{Vibration Response}}$$

NFM Plywood Floating Floor System

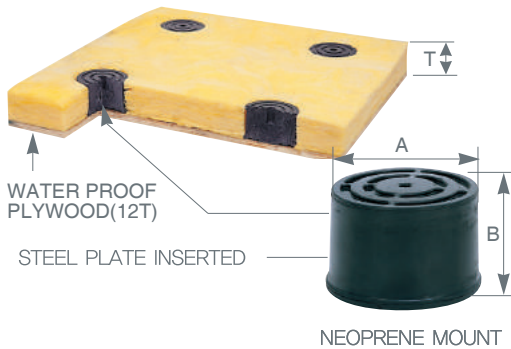

■ Features

As a kind of form work floor system, it absorbs noise, shock and vibration generated in air conditioning rooms, machine rooms and other special facilities like the jack-up system does. But, unlike the jack-up system, it is easier to install as it requires no floating floor to be lifted. In particular, the high-density glass wool inside the product helps work better than the jack-up system in all ranges of frequency. It is designed according to the waterproof plywood standards to keep the mounts at regular intervals when installed next to each other in a horizontal position.

■ Dimension & Selection Guide

| Model | Capacity (kgf) | Deflection (mm) | Hardness (Hs) | Dimension(mm) | | Others | |
|----------|----------------|-----------------|---------------|---------------|-------|---------------------------|--------------------|
| | | | | A(mm) | B(mm) | Absorption material T(mm) | SLAB Thickness(mm) |
| NFM-250 | 250 | 8 | 55±5 | 60 | 50 | 50 | 100~150 |
| NFM-500 | 500 | 8 | 55±5 | 80 | 50 | 50 | 100~150 |
| NFM-1000 | 1000 | 8 | 55±5 | 80 | 50 | 50 | 100~150 |

(NOTE) The mentioned size and scale can be altered to improve the quality performance and capacity of the product without any notice.

■ NFM Plywood Panel Configuration

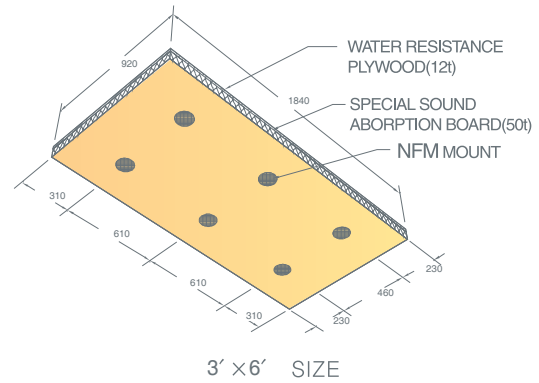
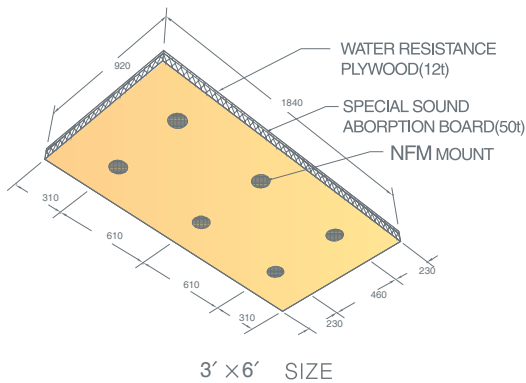

■ NFM Plywood Panel Installation features



NFM Plywood Floating Floor System

■ NFM plywood panel Installation Order

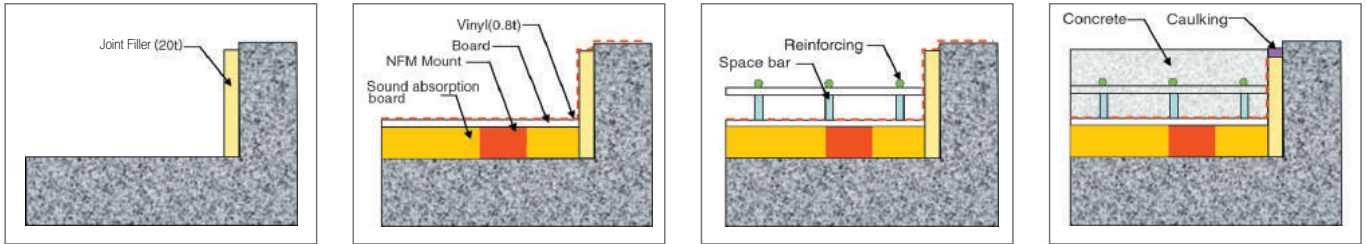

1. Clear the surface of the floor where nfm mount is to be installed, maintain a level surface and keep it dry.
2. Fix the drain, vertical pipes and ducts.
3. Insert the spool pipe seal on the general pipe or electric pipe.
4. Attach the joint filler on the wall or pillar that will come in contact with the slab of plywood panel system.
5. Install nfm plywood panel according to the approved drawing.
6. Spread two layers of 0.08Mm-thick plastic sheet (polyethylene film) over the panel and then attach it using the waterproof tape. The plastic sheet should be large enough to cover the top of the iso pink.
7. Install the steel reinforcement as shown in the approved drawing. At this point, be cautious not to damage the plastic sheet.
8. Pour the concrete at once, so that it can have the strength of 3000 psi.
9. Leave it for curing.
10. Once the floor is completely cured, remove the plastic sheet and then do the caulking with 10mm-thick sealant.

■ NFM Plywood Panel System Transmission Loss DATA

| Frequency(Hz) | 63 | 125 | 250 | 500 | 1000 | 2000 | 4000 |
|-----------------------|----|-----|-----|-----|------|------|------|
| Transmission Loss(dB) | 54 | 59 | 73 | 83 | 89 | 97 | 106 |

■ Performance Test Data

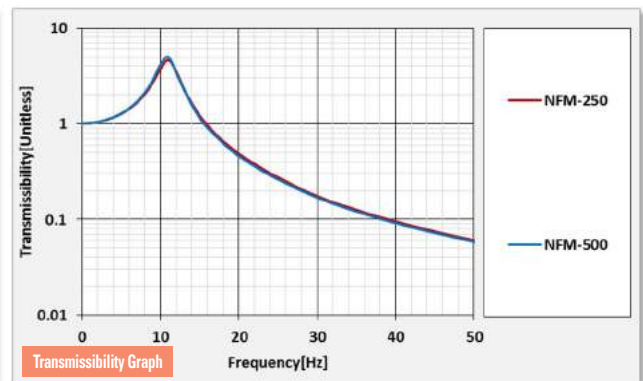
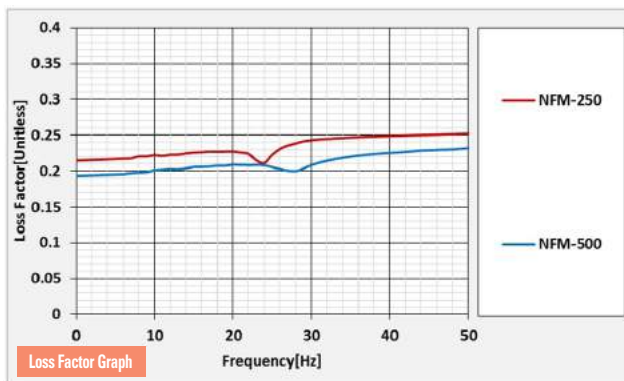
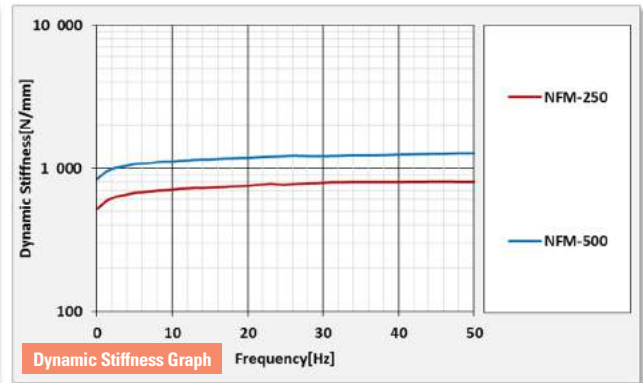
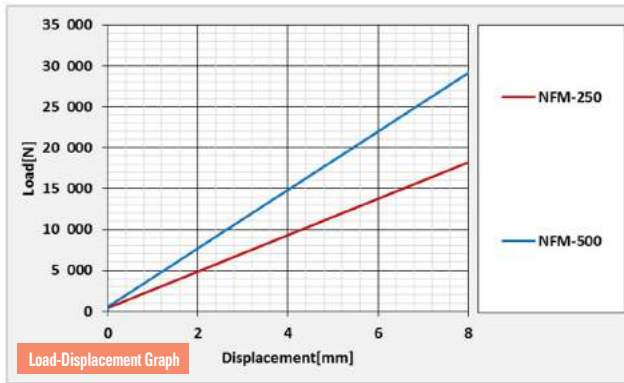

NFA Fiber Glass Sound Absorbing Board

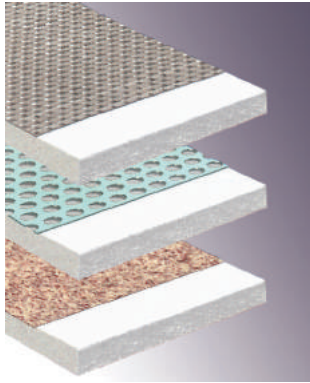

■ Features

The NFA board is the perfect non-combustible sound-absorbing material treated with GlassCloth and Fabric using an E-glass fiber needle mat. It offers higher sound-absorbing power compared with other products of the same thickness. Plus, it is the first sound-absorbing material in Korea that is treated with the Roving Cloth, which made it last longer and look beautiful outside.

■ Sound Absorbing Coefficient (Reverberation Method)

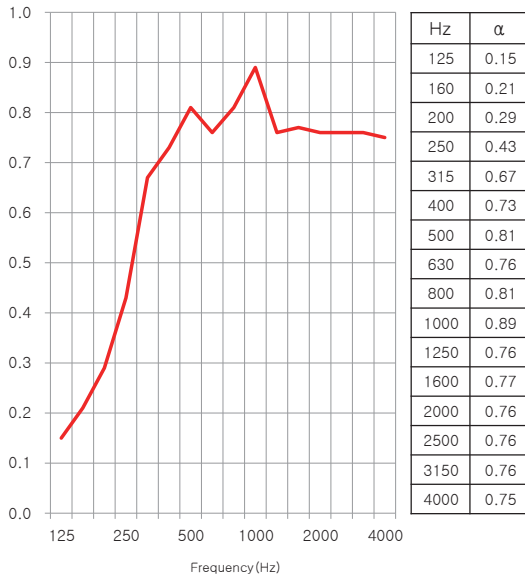

■ NFA-GC TYPE

As the sound-absorbing material for construction and industrial fields, NFA-GC is made of an E-glass fiber needle mat covered with Glass Cloth. It is the most efficient sound-absorbing material that copes with medium/high frequency range.

■ Usage

Used for sound absorption in power generator rooms, air conditioning rooms and industrial facilities

■ Size 1000X1000X20mm, 25mm/THK

■ NFA Merit

1. Excellent noise attenuation
The NFA sound-absorbing board with a density higher than 160Kg/m³ has higher sound absorbing coefficient compared to other products of the same thickness. Because three different medium are stacked up, it copes better with physical properties of sound. Plus, it has a high transmission loss, which provides excellent noise attenuation when installed.
2. Made up of perfect non-combustible natural mineral material, it lasted 2 hours in the level-1 fireproof construction test.
3. It is light, economical, easy to handle and install and moreover, generates less dust.
4. Because it is made up of E-glass fiber, which is natural mineral having excellent durability and safety, it has a chemical resistance with a high durability. And it has a low thermal expansion coefficient, which means it is unlikely to contract and expand as it is almost never affected by temperature and humidity.

■ Transmission Loss (NFA Sound Absorbing Board25T)

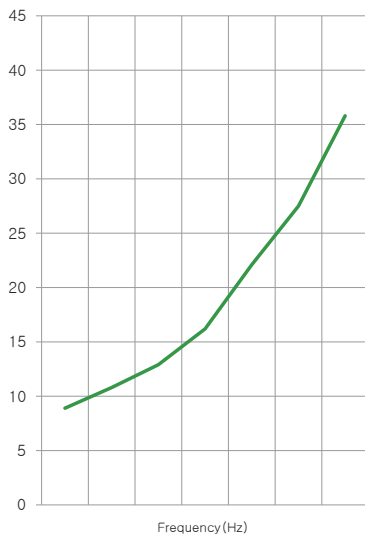

| Frequency(Hz) | 63 | 125 | 250 | 500 | 1000 | 2000 | 4000 |
|---------------|-----|------|------|------|------|------|------|
| 25T board | 8.9 | 10.8 | 12.9 | 16.2 | 22.1 | 27.5 | 35.8 |

■ NFA sound-absorbing board installation

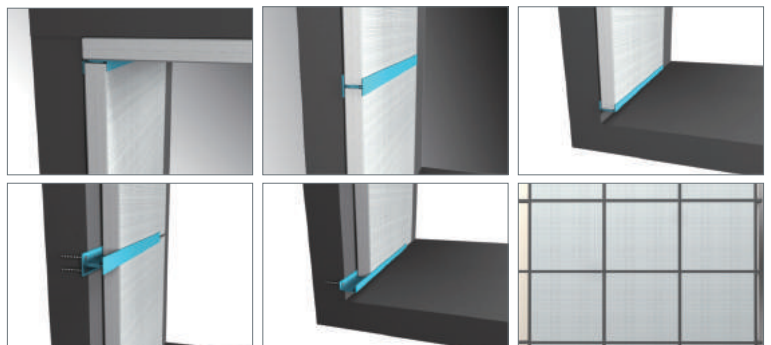

WM1 / WM2 / WM3 Isolated Stud Neoprene Mount

■ Suspended ceiling

The aerial density of a suspended ceiling is much lower than the hardness of the floor SLAB and in this regard, noise is absorbed by in-between space (usually 30mm deep) rather than the ceiling itself. To block the transfer of vibration to the ROADBAR through the structure and control resonance of the ceiling, a rubber or hybrid spring hanger is used.

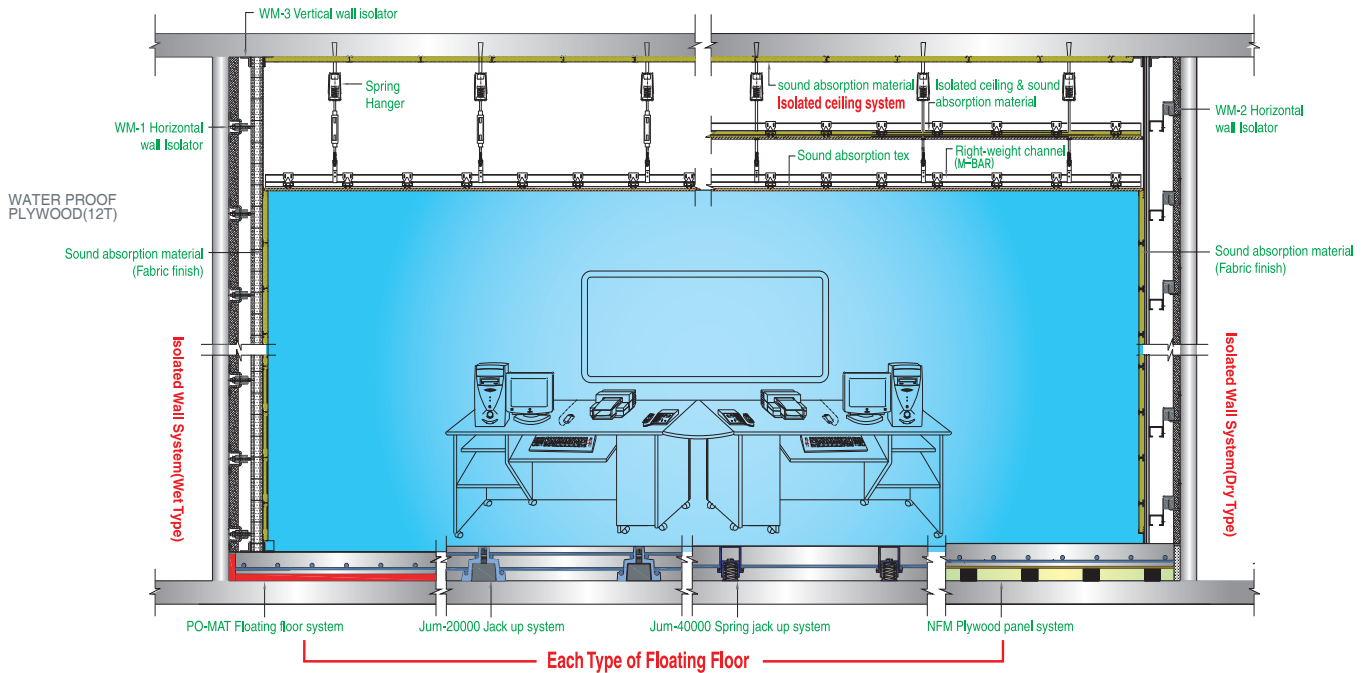

■ Double-wall

To maintain quiet indoors, architectural soundproofing structures are as important as soundproofing using building equipment. The double-wall works as a vibration insulator to prevent the vibration of the wall by sound pressure from passing through the building structure. This double-wall system can be applied on both wet and dry walls. The transmission loss of the double wall is determined based on the structure of the air layer and its aerial density.

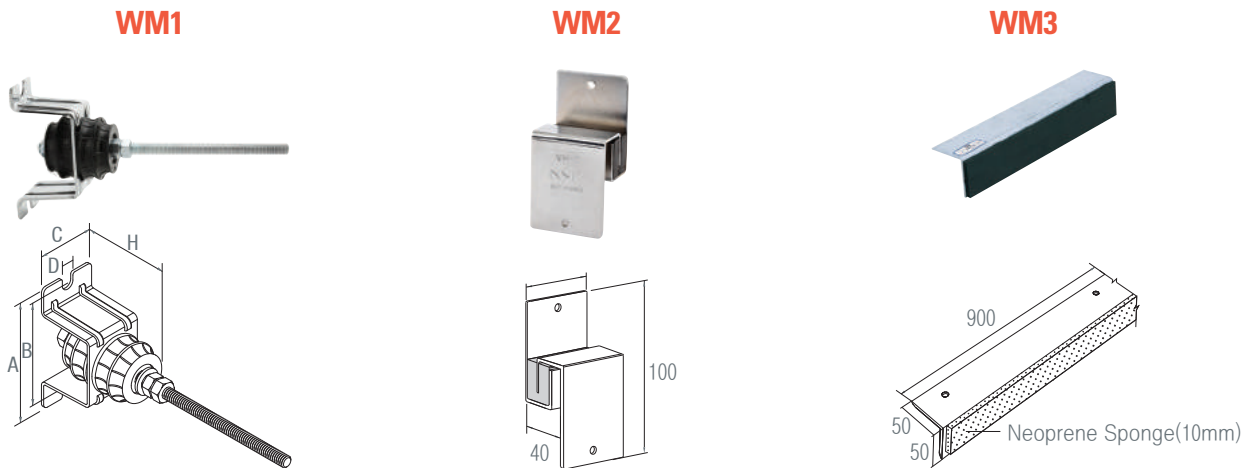

■ Dimension & Selection Guide

| Model/Capacity | Dimension | | | | |
|----------------|-----------|-------|-------|-------|--------|
| | A(mm) | B(mm) | C(mm) | D(mm) | AH(mm) |
| WM1-50 | 108 | 95 | 50 | 11 | 86 |
| WM1-150 | 148 | 124 | 70 | 13 | 114 |

(NOTE) The mentioned size and scale can be altered to improve the quality performance and capacity of the product without any notice.

Shock
Control



ISO 9001/ISO 14001
OHSAS 18001
MADE IN KOREA



SHOCK CONTROL

Water Hammer Arrester Principle

1. Introduction

Water hammer phenomenon means the explosive power occurring when the incompressible fluid flowing within a piping system suddenly changes its flow velocity, and the accompanying impulsive tone and vibration.

When water hammer occurs, an extremely strong shock wave reciprocates back and forth along the pipe system, and its energy remains until it is extinguished by the viscosity of the piping material and the viscous power of the fluid.

The shock wave occurs when the valve inside the piping is suddenly closed causing the speed of fluid to change suddenly. As recent valves are automatically operated by electricity, air pressure or spring, with even manual system operated by one-touch system in many cases, leading to the quick opening/closing of valves, the phenomenon of water hammer occurs more frequently while its strength is getting stronger.

2. Occurrence of water hammer phenomenon

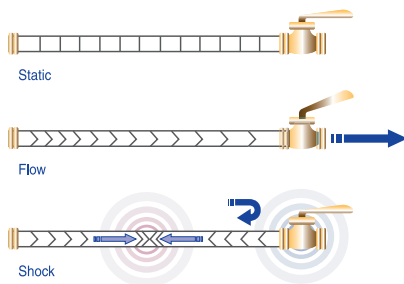

[Figure 1] Generation of water Hammer

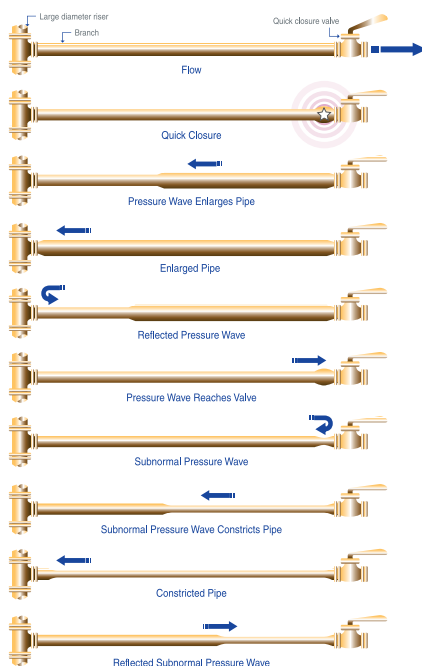

[Figure 2] Illustrations of a Shock Wave

As shown in [Figure 1], shock wave occurs and is transmitted in the opposite direction if the end valve is quickly closed while fluid is moving inside the piping. The transmission speed of this shock wave is same as the speed of sound, and is 1200~1500m/s in case the fluid is water. [Figure 2] shows the movement of shock wave and changes occurring at that time. As shown in this Figure, when the shock wave reciprocates for 1 cycle, the affected piping repeats the process of expansion -> recovery -> contraction -> recovery. An explosive power at this time reacts to the pipe wall, creating impulsive tone and vibration like when the piping is hammered. Components including valves and fittings or even the piping itself may be damaged by the pressure of the shock wave, or joints may be loosened leading to water leakage.

3. Impact strength

Shock wave occurs when valves are quickly opened or closed. Quick opening or closing means a case where the valve opening or closing speed is $2L/a$ second or less. If the valve opening or closing speed is longer than $2L/a$ second, no shock wave occurs. In such case, the dynamic pressure of the fluid changes to static pressure causing pressure to rise only to the level of static pressure.

This is called surging. When water hammer occurs, the maximum pressure of shock wave is calculated as follows in Joukowsky's formula:

$$Pr = \rho \alpha \nu \text{ (pa)}$$

$$= \rho \alpha \nu / 98000 \text{ (kgf/cm}^2\text{)}$$

Where : Pr : Pressure rise above flow pressure

ρ : Specific weight of liquid (kg/m³;
1000 in case of water)

α : Velocity of pressure wave (m/s;
1200~1500 average for water)

ν : Change in flow velocity, initial flow
velocity(m/s) when totally closed

L : Length of pipe(m) from point of
valve closure to point of relief

4. Shock Wave

- ▶ Ruptured Piping
- ▶ Leaking Connections
- ▶ Weakened Connections
- ▶ Pipe Vibration and Noise
- ▶ Damaged Check Valves
- ▶ Damaged Water Meters
- ▶ Damaged Pressure Regulators and Gauges
- ▶ Damaged Recording Apparatus
- ▶ Loosened Pipe Hangers and supports
- ▶ Ruptured Tanks and Water Heaters
- ▶ Premature Failures of Other Equipment and Devices

5. Water hammer arrester test system

[Figure 3] and [Figure 4] show a water hammer arrester test system owned by NSV Co., Ltd, which was designed based on KS B 2375 standard.

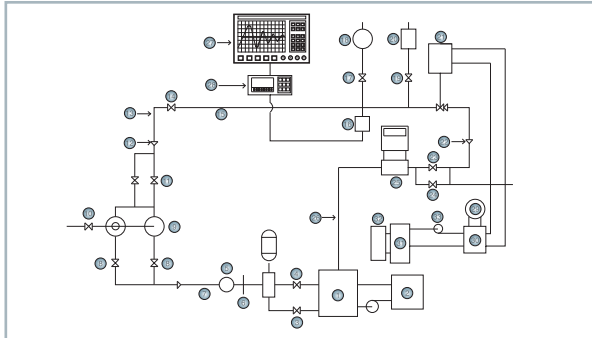

[Figure 3] KS B 2375 Water hammer arrester test system

| No. | TYPE | No. | TYPE | No. | TYPE |
|-----|------------------------------|-----|-----------------------|-----|------------------------------|
| 1 | Water Tank | 12 | Return Bend | 23 | 50A Meter Valve |
| 2 | Heater | 13 | Valve | 24 | 15A Meter Valve |
| 3 | 50A Gate Valve | 14 | 50A Gate Valve | 25 | Flow Meter |
| 4 | 40A Gate Valve | 15 | Steel Pipe | 26 | Steel Pipe |
| 5 | Centrifugal Pump | 16 | Pressure Transducer | 27 | Oscilloscope |
| 6 | Water Return TEE, Elbow | 17 | Ball Valve | 28 | Digital Pressure Gage |
| 7 | Steel Pipe | 18 | Pressure Gage | 29 | Booster Pump |
| 8 | 50A Gate Valve | 19 | Ball Valve | 30 | Water Pressure Solenoid Pump |
| 9 | Pneumatic Water Tank(113.5L) | 20 | Water Hammer Arrester | 31 | Oil Tank |
| 10 | 15A Globe Valve | 21 | Serge Valve | 32 | Oil Cooler |
| 11 | 80A Gate Valve | 22 | 250A Return Bend | 33 | Cycle Meter |

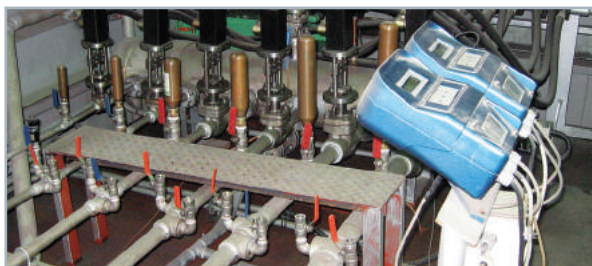

[Figure 4] Water hammer arrester test system

6. Water hammer arrester

To prevent water hammer, a gas chamber (air in general) capable of absorbing fluid pressure may be installed on the pipeline having quick opening/closing valves. The result of test conducted by the PDI (Plumbing & Drainage Institute), U.S.A. by types and uses of the water supply systems, pipe length, and pipe diameter are generally used by related industries. [Figure 4] shows the air chamber installed in early stage. In this case, air inside the chamber makes direct contact with the fluid and is dissolved in the fluid or lost in the form of bubbles, preventing the occurrence of water hammer. Recent water hammer arresters are equipped with air bladders and pistons inside the air chamber to isolate water from air in order to prevent loss of air.

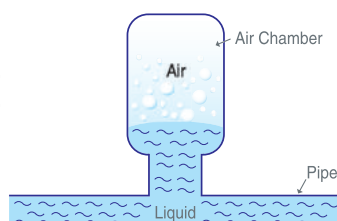

7. Principle and features of water hammer arresters

When incompressible fluid moves and creates shock wave, shock cannot be absorbed; however, gas with strong compressibility, particularly air and nitrogen featuring high stability may be injected separately in the flow of fluid, and shock energy can be absorbed because the initial volume is contracted when impact power is generated.

The features of the water hammer arresters, which allow normal flow of current by reducing the high shock energy created by the water hammer phenomenon occurring within the piping system, can be summarize as follows:

- ▶ Prevents pulsation during pump operation
- ▶ Absorbs noise and vibration generated by the water hammer phenomenon.
- ▶ Prevents impulsive pressure of fire-fighting piping facilities.
- ▶ Maintains silent environment on highways adjacent to people.
- ▶ Attenuates and absorbs noise and vibration when shock occurs by the opening or closing of check valves when the cooling or heating circulating pump is started or shut off by automatic control.

| TYPE | Built-in rubber membrane | Built-in bellows | Built-in piston |
|----------|--|--------------------------|--|
| Features | | | |
| Use | Prevents water hammer and pulsation phenomenon of the piping system. Protects flush valves of sanitary facilities. | Prevents oil pipe shock. | Controls the hydraulic equipment pressure. Sanitary. |

8. Calculation of the water hammer arrester capacity

The internal volume of the water hammer arresters air bladder can be used to calculate capacity as follows based on Greer Mercier's test formula:

$$V = \frac{4.0 \times 10^{-3} \times QP_1(0.016L - tc)}{P_1 - P_2} \text{ [Liter]}$$

Where Q: flow prior to shutting off valve (liter/min)

P₁: In general, the allowable impact pressure (kgf/cm²) is 1.5 times P₂ or 1.2 times in case value is more than 250A, and 2 times in the case of sprinklers.

P₂: Pressure prior to shutting off valve (kgf/cm²)

tc: Reciprocating time of pressure wave after closing valve.

(0.3~0.5 sec) = 2 L/C

L: Overall pipe length (m)

Water Hammer Arrester Technical Data

1. Major fixture unit

| Fixtuer | Supply control | Common use | | | Private use | | |
|-----------------|----------------------------|------------|-----------|-------|-------------|----|-----|
| | | Total | WS | HWS | Total | WS | HWS |
| Closet | Flush valve | 10 | 10 | | 6 | | |
| | Flush tank | 5 | 5 | | 3 | | |
| Urinal | Large stool | 10 | 10 | | | | |
| | Medium stool, wall-mounted | 5 | 5 | | | | |
| | Small stool, wall-mounted | 3 | 3 | | | | |
| Wash basin | Faucet | 2 | 1 1/2 (2) | 1 1/2 | 1 | 1 | 1 |
| Shower head | Mixed faucets | 4 | 2(4) | 3 | 2 | 1 | 2 |
| Bath room | Flush valve | | | | 8 | 8 | 3 |
| | Flush tank | | | | 6 | 6 | 3 |
| Separate shower | Mixed faucets | | | | 2 | 1 | 2 |
| Service tank | Faucets | 3 | 3 | 3 | | | |
| Laundry tank | Faucets | | | | 3 | 3 | 3 |
| Mixed fixture | Faucets | | | | 3 | 3 | 3 |

※ WS:Water supply, HWS:Hot-Water supply

※ What is fixture unit?

This is the data obtained by PDI through long research and tests. It is a figure derived by dividing the water supply load fixture unit of a variety of water supply fixtures into the pre-determined basic flow, which in turn means the figure which represents how many times the value is if the wash basin is used when water pressure is 1kgf/cm².

2. Standard pipe pressure

Ideal pressure applied to pipe connected to sanitary fixtures is 4.0kgf/cm² or less.

If water pressure is too high, reducing valves should be used to protect fixtures.

Water hammer arresters can be selected as follows based on pressure within pipe.

| | |
|---|---|
| If water pressure is 4.5kgf/cm ² or less | Use FU standard specifications (standard specifications) |
| If water pressure exceeds 4.5kgf/cm ² | Use fixtures with specifications 1 step higher than the standard specifications. Standards of selecting water hammer arresters based on pipe pressure |

3. Standard of pipe length

Specifications of the fixtures to be installed on the supply pipe connected to a single sanitary fixture or equipment located far away are as follows.

(A) In case of pipe with water pressure 4.5kgf/cm² or less

| Pipe diameter (B) | Pipe length | | | | | |
|-------------------|-------------|------|-----|--------|--------|---------|
| | 1/2" | 3/4" | 1" | 1 1/4" | 1 1/2" | 2" |
| 25ft(8m) | B | B | C | D | E | F |
| 50 (15) | B | C | D | E | F | C,F |
| 75 (20) | C | D | E | F | C,F | F,F |
| 100 (30) | D | E | F | C,F | F,F | E,F,F |
| 125 (40) | D | E | C,F | D,F | F,F | B,F,F,F |
| 150 (50) | E | F | C,F | F,F | D,F,F | F,F,F,F |

(B) In case of pipe with water pressure exceeding 4.5kgf/cm² but less than 6kgf/cm²

| Pipe diameter (B) | Pipe length | | | | | |
|-------------------|-------------|------|----|--------|--------|-------|
| | 1/2" | 3/4" | 1" | 1 1/4" | 1 1/2" | 2" |
| 25ft(8m) | A | A | B | C | D | E |
| 50 (15) | A | B | C | D | E | F |
| 75 (20) | B | C | D | A,E | F | E,F |
| 100 (30) | C | D | E | F | C,F | F,F |
| 125 (40) | C | D | F | A,F | E,F | E,F,F |
| 150 (50) | D | E | F | D,F | F,F | F,F,F |

(A) is applied to an ideal piping system where the water pressure of its branch pipe connecting to sanitary fixtures is 4.0kgf/cm² or less; and in case pipe water pressure exceeds 4.5kgf/cm² but is less than 6kgf/cm², as shown in (B), it is recommendable to select fixtures with specifications higher by 1 step than those of other fixtures used on piping system with water pressure 4.5kgf/cm² or less.

4. Standard method of installation

Method 1) In case the length of branch pipe is less than 6m.

Install arresters at the center of the branch pipe connected to the last 2 sanitary fixtures.

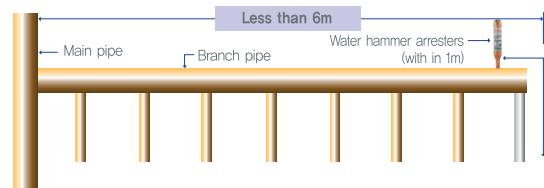

[Figure 6] Installation position based on method 1

Example] Select the specifications of the water hammer arresters required for water supply and hot-water supply system, as shown in [Figure 6].

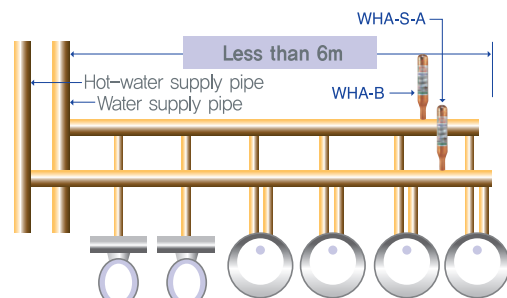

[Figure 7] Installation position based on method 1

| Fixture | For water supply | For hot-water supply |
|--------------|------------------------------------|-------------------------------------|
| Closet (F.V) | $10 \times 2 = 20$ | - |
| Wash basin | $1.5 \times 4 = 6$ | $1.5 \times 4 = 6$ |
| Total | 26 | 6 |
| Select | WHA-B \times 1EA (FU : 12~32) | WHA-S-A \times 1EA (FU : 4~11) |

(Illustration) Results of FU and model selection

Method 1) If the length of branch pipe exceeds 6m

Divide the entire number of FU covering overall section into a half, and install 2 water hammer arresters.

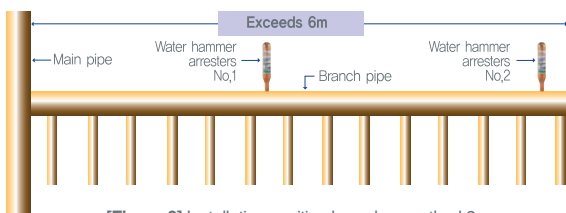

[Figure 8] Installation position based on method 2

Example] Select the specifications of the water hammer arresters required for water supply and hot-water supply system, as shown in [Figure 8].

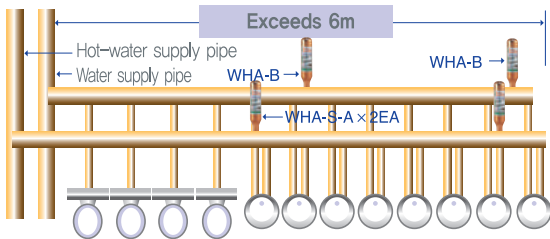

[Figure 9] Installation position based on method 2

| Fixture | For water supply | For hot-water supply |
|--------------|------------------------------------|-------------------------------------|
| Closet (F.V) | $10 \times 4 = 40$ | - |
| Wash basin | $1.5 \times 8 = 12$ | $1.5 \times 8 = 12$ |
| Total | 52 | 12 |
| Select | WHA-B \times 2EA (FU : 12~32) | WHA-S-A \times 2EA (FU : 1~11) |

(Illustration) Results of FU and model selection

Method 3] In case the length of pipe to the fixture is long, install arresters as near to the quick opening or closing point as possible.

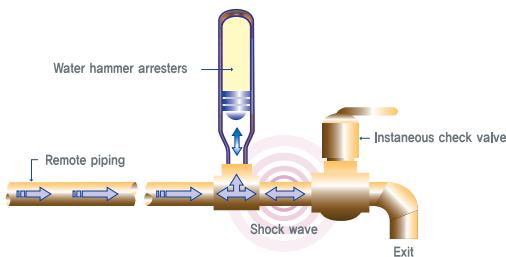

[Figure 10] Installing water hammer arresters on remote piping of individual sanitary fixtures.

Example] In case the length of pipe to the fixture is long, install arresters as near to the quick opening or closing point as possible.

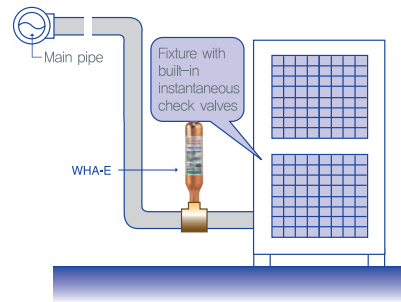

[Figure 11] Equipment with built-in instantaneous check valves

| Item | | For water supply |
|--|---------------------------------------|------------------------------|
| Conditions | Pipe diameter (B) | 1 " |
| | Pipe length (m) | 28 |
| | Water pressure (kgf/cm ²) | 3.74 |
| | Flow velocity (m/s) | 2.44 |
| Selection Refer to (A) of <Pipe length-based selection table> | | WHA-E X 1EA (FU:114 ~154) |

(Illustration) Results of selecting models based on pipe length.

Example] Select appropriate type of water hammer arresters to fit the single fixture or pressure tank connected to the piping system (equipped with instantaneous check valves) as shown in [Figure 12].

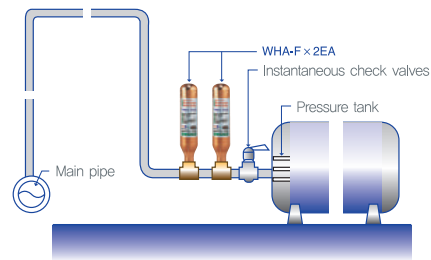

[Figure 12] Pressure tank equipped with instantaneous check valves

| Item | | For water supply |
|--|---------------------------------------|------------------------------|
| Conditions | Pipe diameter (B) | 2 " |
| | Pipe length (m) | 30 |
| | Water pressure (kgf/cm ²) | 4.08 |
| | Flow velocity (m/s) | 3.05 |
| Selection Refer to (A) of <Pipe length-based selection table> | | WHA-E X 2EA (FU:155 ~330) |

(Illustration) Results of selecting models based on pipe length.

Water Hammer Arrester Technical Data

Example] Select appropriate type of water hammer arresters to fit the single fixture(service sink) connected to the water supply and hot-water piping system as shown in [Figure 13].

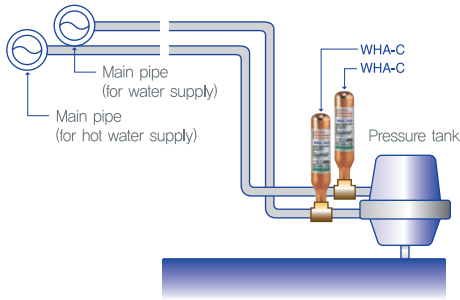

[Figure 12] Single fixture (service sink)

| Item | | For water supply |
|--|---------------------------------------|----------------------------|
| Conditions | Pipe diameter (B) | 3/4 " |
| | Pipe length (m) | 20 |
| | Water pressure (kgf/cm ²) | 3.4 |
| | Flow velocity (m/s) | 1.8 |
| Selection Refer to (A) of <Pipe length-based selection table> | | WHA-C X 2EA (FU:33 ~60) |

(Illustration) Results of selecting models based on pipe length.

Example] Select appropriate type of water hammer arresters to fit the single fixture or open tank connected to the piping system (equipped with instantaneous check valves) as shown in [Figure 14].

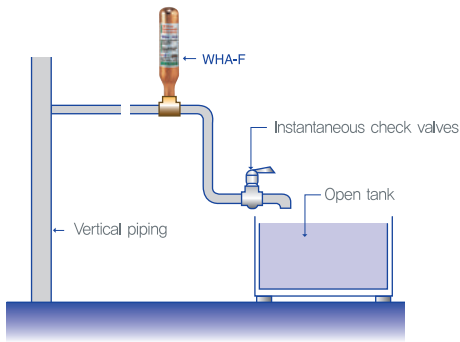

| Item | | For water supply |
|--|---------------------------------------|------------------------------|
| Conditions | Pipe diameter (B) | 1 1/4 " |
| | Pipe length (m) | 30 |
| | Water pressure (kgf/cm ²) | 3.6 |
| | Flow velocity (m/s) | 2.44 |
| Selection Refer to (A) of <Pipe length-based selection table> | | WHA-F X 1EA (FU:155 ~330) |

(Illustration) Results of selecting models based on pipe length.

Example] Select appropriate type of water hammer arresters to fit the single fixture (processing tank) connected to the water supply and hot-water piping system as shown in [figure 15]

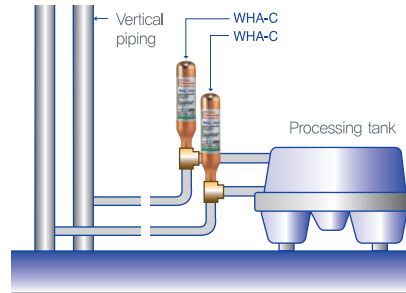

[Figure 15] Processing tank equipped with instantaneous check valves

| Item | | For water supply |
|--|---------------------------------------|----------------------------|
| Conditions | Pipe diameter (B) | 1 " |
| | Pipe length (m) | 15 |
| | Water pressure (kgf/cm ²) | 3.1 |
| | Flow velocity (m/s) | 2.44 |
| Selection Refer to (A) of <Pipe length-based selection table> | | WHA-C X 1EA (FU:33 ~60) |

(Illustration) Results of selecting models based on pipe length.

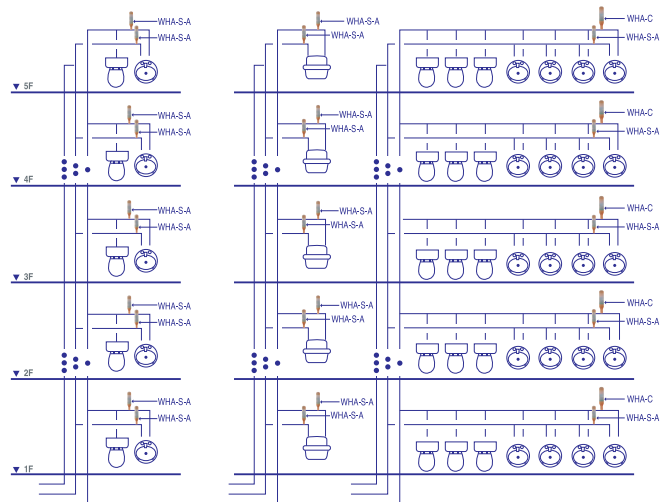

[Figure 9] Plumbing system diagram with water hammer arresters selected

5. Maximum impact pressure measurement data

▶ WHA-S-AA Water hammer arrester test result
(Designed pressure in pipe: 4.0kgf/cm²)

▶ WHA-S-A Water hammer arrester test result

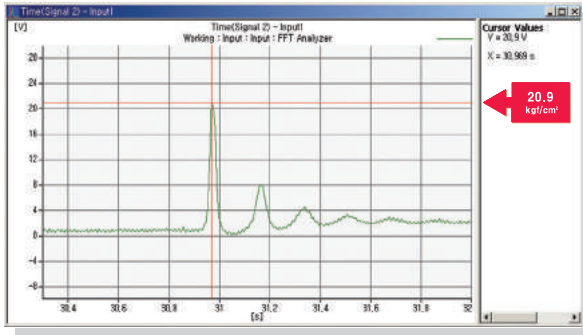

• Water hammer arrester off[20.9 kgf/cm²] •

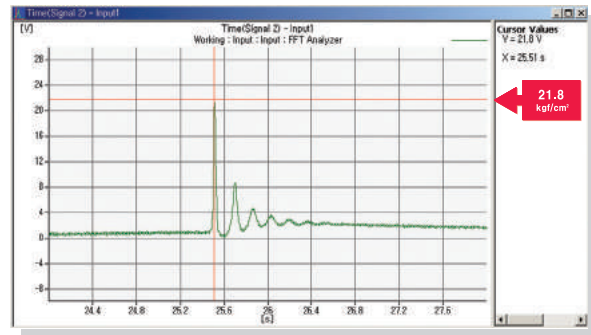

• Water hammer arrester off[21.8 kgf/cm²] •

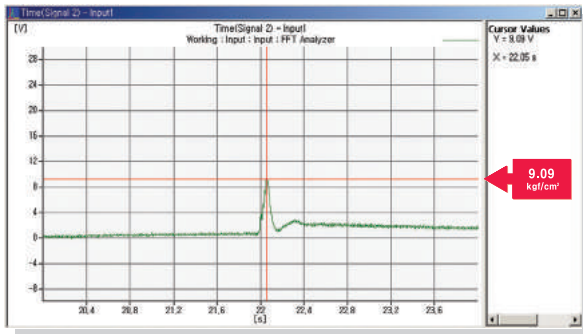

• Water hammer arrester on[9.09 kgf/cm²] •
100,000cycles

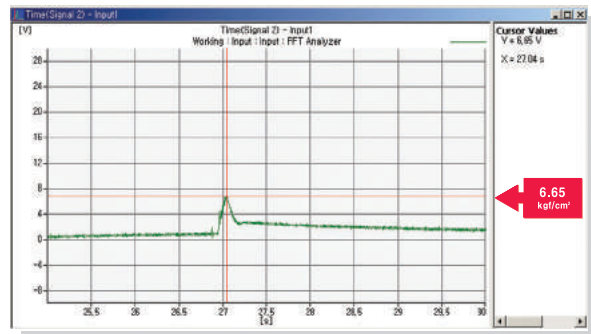

• Water hammer arrester on[6.65 kgf/cm²] •
100,000cycles

6. Example of application, and the installation position of water hammer arresters

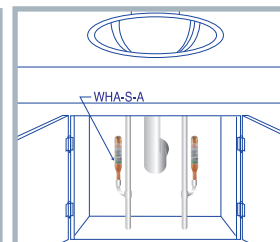
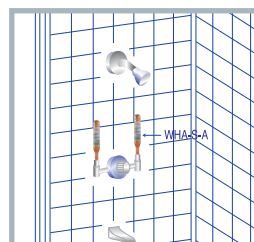
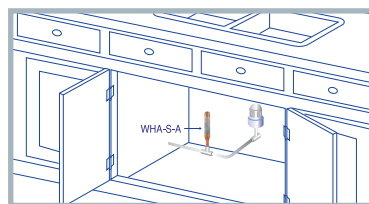
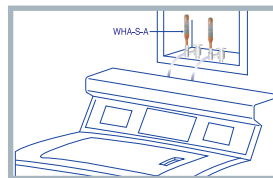
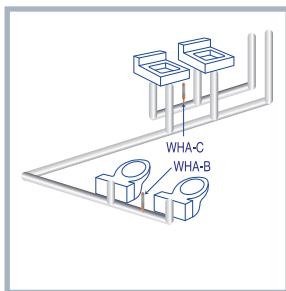
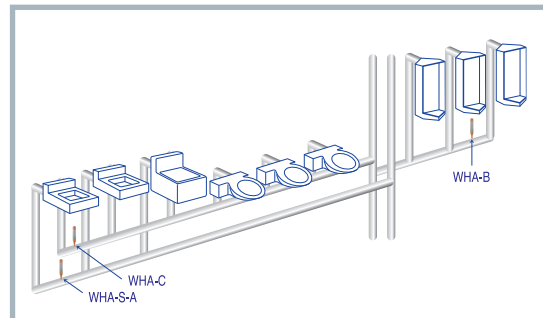
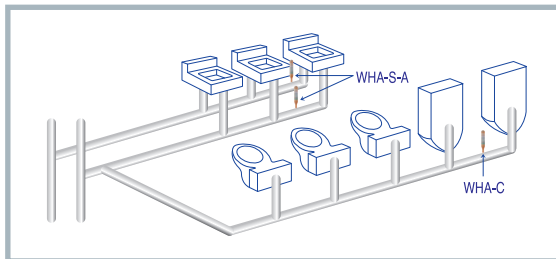

WHA Water Hammer Arrester (CM Adapter/PB Coupling Type)



CM Adapter Type

PB Coupling Type

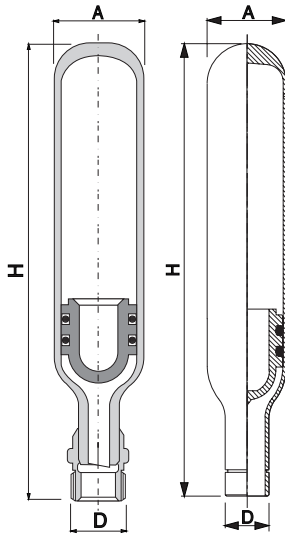

■ Features

This product is made up of materials that are harmless to humans, including pistons, an O-ring and copper pipe. Because the air layer is completely separated from the water with the presence of O-ring, it guarantees a semi-permanent life span. It is made in compliance with PDI (Plumbing and Drainage Institute) standard, that is FU (Fixture Unit) definition and each model is proven to have a volume appropriateness and reliability through 200,000 cycle tests.

- Working pressure(PV) : 10Kgf/cm²
- Maximum impulsive pressure(P) : 38Kgf/cm²
- Maximum working temperature : 120°C

■ Specification

| No. | Name of Components | Material | Remark |
|-----|--------------------|----------|---|
| 1 | Body | Copper | (KS D 5310,L-type), Molding |
| 2 | Piston | P.P | Pressure-lubricated Dow-Coming 111 silicon compound, FDA approved (Uses the FDA-approved lubricant) |
| 3 | O-ring | EPDM | |
| 4 | CM Adapter | Brass | KS B 1544 |
| 5 | Air Chamber | - | 4.0kgf/cm ² Air Charge |
| 6 | Soldering | Sn & Ag | Tin 96% & Silver 4%, is Harmless to humans (Uses items that are certified by the national institute) |

■ Dimension & Selection Guide

PDI certificate for WHA-S-A & S-AA model

| Type | Dimension (mm) | | | Weight (kg) | Air Volume (cc) | Fixture Capacity Unit |
|--------------|----------------|-----|-----|-------------|-----------------|-----------------------|
| | A | ØD | H | | | |
| WHA-S-AA(CM) | 20A(22.22) | 15A | 150 | 0.2 | 31 | ~3 |
| WHA-I-AA(PB) | | | 153 | 0.1 | | |
| WHA-S-A(CM) | 25A(28.58) | 15A | 210 | 0.2 | 80 | 4~11 |
| WHA-I-A(PB) | | | 215 | 0.2 | | |
| WHA-S-B(CM) | 32A(34.92) | 20A | 210 | 0.3 | 110 | 12~32 |
| WHA-S-C(CM) | 50A(53.98) | 25A | 226 | 0.4 | 180 | 33~60 |
| WHA-S-D(CM) | 50A(53.98) | 25A | 265 | 0.7 | 320 | 61~113 |
| WHA-S-E(CM) | 50A(53.98) | 25A | 338 | 0.8 | 470 | 114~154 |
| WHA-S-F(CM) | 50A(53.98) | 25A | 400 | 0.9 | 590 | 155~330 |

(NOTE) The mentioned size and scale can be altered to improve the quality performance and capacity of the product without any notice.

WHA-3000 STS Sanitary Water Hammer Arrester (CM Adapter)

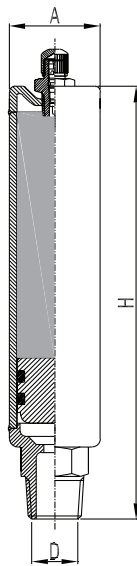

■ Features

It is made up of special materials like Piston and O-ring with stainless steel tube having excellent corrosion resistance and because air layer is completely separated from water thanks to O-ring, it guarantees semi-permanent life span. It is made in compliance with PDI (Plumbing and Drainage Institute Standard), that is FU (Fixture Unit) definition and each model is proved to have volume appropriateness and reliability through 200,000 cycle tests.

- Working pressure(PV) : 10kgf/cm²
- Maximum impulsive pressure(P) : 32Kg/cm²
- Maximum working temperature : 90°C

■ Specification

| No. | Name of Components | Material | Remark |
|-----|--------------------|----------|---|
| 1 | Body | STS | (Type 304SS), Molding |
| 2 | Piston | P.P | Pressure-lubricated Dow-Corning 111silicon compound, FDA approved (Used the FDA-approved lubricant) |
| 3 | O-ring | EPDM | |
| 4 | Adapter | STS | CM Type |
| 5 | Air Chamber | - | 4.0kgf/cm ² Air Charge |
| 6 | Air Valve | Brass | Cr Plated |

■ Dimension & Selection Guide

| Type | Dimension(mm) | | | Air Volume (cc) | Fixture Capacity Unit |
|-----------|---------------|-----|-----|-----------------|-----------------------|
| | A | ØD | H | | |
| WHA-3015A | 34 | 15A | 163 | 70 | 1~11 |
| WHA-3020B | 38 | 20A | 180 | 110 | 12~32 |
| WHA-3025C | 38 | 25A | 226 | 150 | 33~60 |
| WHA-3025D | 60 | 25A | 224 | 320 | 61~113 |
| WHA-3025E | 60 | 25A | 252 | 390 | 114~154 |
| WHA-3025F | 60 | 25A | 294 | 470 | 155~330 |

(NOTE) The mentioned size and scale can be altered to improve the quality performance and capacity of the product without any notice.

WHA-4000 Water Hammer Arrester (Flange Type)

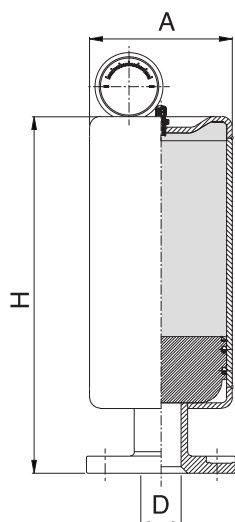

■ Features

It is a semi-permanent water hammer arrester made up of a stainless steel tube having excellent corrosion resistance with a built-in piston moving up and down to prevent the loss of air. Because it is an all-in-one type, it does not cause the leakage of water. Plus, it has a wide range of applications, including the pipe for drinking water. It is for pressures higher than 10kgf/cm² with the pressure gauge on top to check the pressure applied. In general, it is installed on top of the special-purposed pump. Its volume appropriateness and reliability have been proved through 200,000 cycle tests.

The above special order-made model is a hybrid water hammer arrester, which can be installed in the same direction in which fluid moves through a vertical/horizontal pipe.

- Working pressure : 10kgf/cm²/ 20kgf/cm²
- Maximum impulsive pressure : 32Kgf/cm²
- Maximum working temperature : 90°C

■ Specification

| No. | Name of Components | Material | Remark |
|-----|--------------------|--------------------|--|
| 1 | Body | STS | (Type 304SS), Molding |
| 2 | Piston | P.P, ABS | Pressure-lubricated Dow-Coming 111 Silicon Compound, FDA approved (Used the FDA-approved lubricant) |
| 3 | O-ring | EPDM | |
| 4 | Flange | STS | - |
| 5 | Air Chamber | - | 7.5kgf/cm ² |
| 6 | Air Valve | Brass | Cr Plated |
| 7 | Pressure Guage | - | 20, 30, 40kgf/cm ² |
| 8 | Filter Cap | ABS + Wire Netting | |

■ Dimension & Selection Guide

| Type | Dimension(mm) | | | Air Volume(ℓ) | Flange Connection Diameter |
|----------|---------------|-------|-----|---------------|----------------------------|
| | A | ∅D | H | | |
| WHA-4040 | 139.8 | 49.1 | 320 | 1.6 | 40A |
| WHA-4050 | 139.8 | 61.1 | 320 | 1.7 | 50A |
| WHA-4065 | 139.8 | 77.1 | 340 | 2.1 | 65A |
| WHA-4080 | 165.2 | 90.0 | 360 | 3.3 | 80A |
| WHA-4100 | 165.2 | 115.4 | 360 | 3.7 | 100A |
| WHA-4125 | 165.2 | 115.4 | 390 | 4.2 | 125A |
| WHA-4150 | 165.2 | 115.4 | 390 | 4.2 | 150A |
| WHA-4200 | 216.3 | 158.0 | 440 | 9.7 | 200A |
| WHA-4250 | 216.3 | 158.0 | 460 | 9.7 | 250A |

(NOTE) The mentioned size and scale can be altered to improve the quality performance and capacity of the product without any notice.

WHA-5000 Water Hammer Arrester (Line Type)

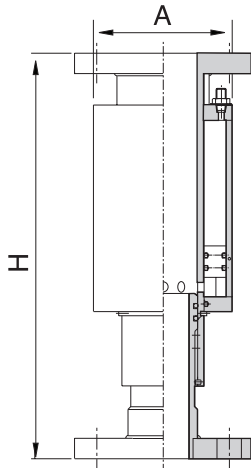

■ Features

It is made up of stainless steel having excellent corrosion resistance with a piston and air layer inside to ease the water hammer. The conventional water hammer arrestors need extra space because they are installed perpendicular to the end of the pipe or valve in the direction of the pipe line, but this product can be installed in a narrow space as it is installed in the middle along the direction of the pipe line.

- Working pressure(Pv) : 10kgf/cm², 20kgf/cm²
- Maximum impulsive pressure(P) : 32kgf/cm²
- Maximum working temperature : 90°C

■ Specification

| No. | Name of Components | Material | Remark |
|-----|--------------------|----------|---------------------|
| 1 | Flange | STS | (TYPE304),Molding |
| 2 | Inner-Body | | (TYPE304),Molding |
| 3 | Outer-Body | | Honing |
| 4 | Air Inlet | Brass | Cr Plated |
| 5 | O-Ring | EPDM | - |
| 6 | Piston | Plastic | Engineering Plastic |

■ Dimension & Selection Guide

| Type | Dimension(mm) | | Air Volume (ℓ) | Flange Connection Diameter |
|----------|---------------|-----|----------------|----------------------------|
| | A | H | | |
| WHA-5050 | 114.3 | 280 | 0.5 | 50A |
| WHA-5065 | 114.3 | 300 | 0.7 | 65A |
| WHA-5080 | 165.2 | 340 | 0.9 | 80A |
| WHA-5100 | 165.2 | 390 | 1.2 | 100A |
| WHA-5125 | 216.3 | 440 | 1.6 | 125A |
| WHA-5150 | 216.3 | 500 | 2.0 | 150A |
| WHA-5200 | 267.4 | 550 | 2.2 | 200A |
| WHA-5250 | 355.6 | 600 | 3.2 | 250A |
| WHA-5300 | 355.6 | 680 | 3.8 | 300A |

(NOTE) The mentioned size and scale can be altered to improve the quality performance and capacity of the product without any notice.

WHA-6000 Water Hammer Arrester (Flange Type)

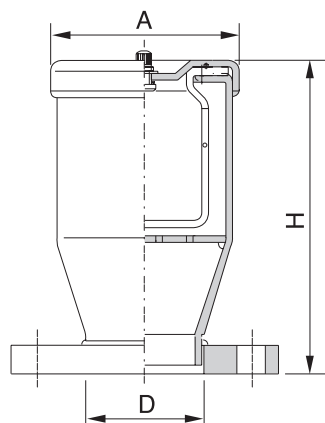

■ Features

It is a semi-permanent water hammer arrester made up of steel with an EPDM air bag inside to prevent the leakage of air. Plus, it absorbs sudden pressure when the shut-off valve is closed. It is usually installed on top of the pump and/or the end of the fire pipe in parking space. Its volume appropriateness and reliability have been proved through 200,000 cycle tests.

- Working pressure : 10kgf/cm², 20kgf/cm²
- Maximum impulsive pressure(P) : 32kgf/cm²
- Maximum working temperature : 90°C

■ Specification

| No. | Name of Components | Material | Remark |
|-----|--------------------|--------------|-----------|
| 1 | Flange | SS400 | Cr Plated |
| 2 | Middle Plate | SS400 | - |
| 3 | Body | SPP | - |
| 4 | Air Bag | EPDM65 | - |
| 5 | Cap | SS400 | - |
| 6 | Air Inlet | BS Cr Plated | KS B 1503 |

■ Dimension & Selection Guide

| Type | Dimension(mm) | | | Air Volume (ℓ) | Flange Connection Diameter |
|----------|---------------|-------|-----|----------------|----------------------------|
| | A | ∅D | H | | |
| WHA-6040 | 124 | 61.1 | 202 | 0.4 | 40A |
| WHA-6050 | 124 | 61.1 | 202 | 0.4 | 50A |
| WHA-6065 | 124 | 77.1 | 202 | 0.4 | 65A |
| WHA-6080 | 150 | 90.0 | 232 | 0.8 | 80A |
| WHA-6100 | 150 | 115.0 | 232 | 0.8 | 100A |
| WHA-6125 | 176 | 141.0 | 265 | 1.4 | 125A |
| WHA-6150 | 176 | 141.0 | 265 | 1.4 | 150A |
| WHA-6200 | 226 | 166.6 | 315 | 3.6 | 200A |
| WHA-6250 | 226 | 166.6 | 340 | 3.6 | 250A |

(NOTE) The mentioned size and scale can be altered to improve the quality performance and capacity of the product without any notice.

VD10 Friction & Wire Damper

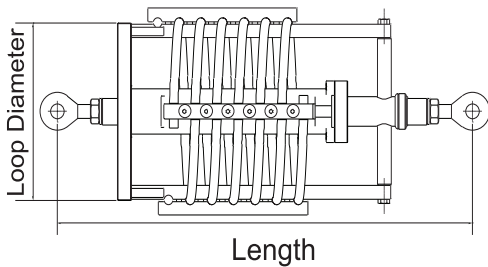
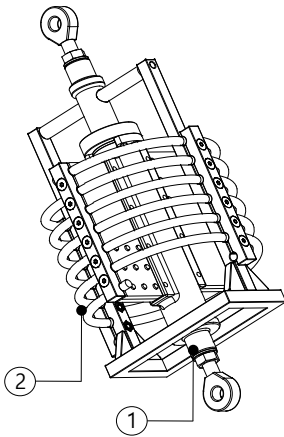

■ Features

VD10, a parallel combination of a friction damper and a wire damper (using elasticity and damping characteristic of wire rope), is an effective damping device with high elasticity and damping characteristic to seek stability and vibration isolation simultaneously. You can save money because there is no risk of oil leakage, no limit to service life, and no maintenance, unlike existing hydraulic or mechanical dampers.

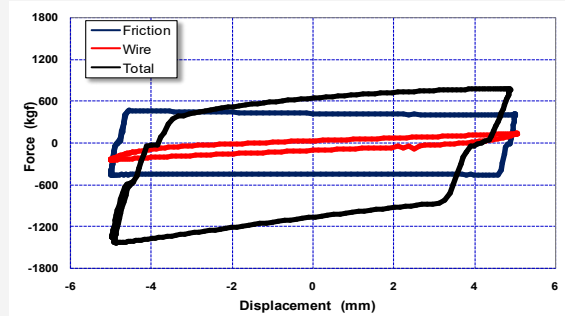

■ Specification

| No. | Name of Components | Material |
|-----|--------------------|----------|
| 1 | Friction Damper | STS304 |
| 2 | Wire Damper | STS304 |

■ Specification

VD10 aims to isolate vibration. A fluid flow inside the pipe produced a vibration frequency, which comes close to the natural frequency of the pipe itself and then resonance occurs. Absorbing the energy from the resonance, this product stabilizes dynamic behavior of the piping system and prevents the vibration from being transmitted to the support structure.

■ Dimension & Selection Guide

| Type | Rated Load (kgf) | Stroke (mm) | Spring Rate | | Dimension | | | |
|-----------|------------------|-------------|-------------|------------|-----------|--------|------|------|
| | | | Mid-Stroke | Max-Stroke | Loop Dia. | Length | Wire | Loop |
| VD10-1000 | 1000 | ±25 | 66 | 186 | 180 | 1000 | Φ16 | 6 |
| VD10-2000 | 2000 | ±40 | 27 | 75 | 250 | | | |
| VD10-2500 | 2500 | ±50 | 23 | 65 | 300 | | | |
| VD10-3000 | 3000 | ±50 | 18 | 50 | 300 | | | |

(NOTE) The mentioned size and scale can be altered to improve the quality performance and capacity of the product without any notice.

VD20 Vibration Friction Damper

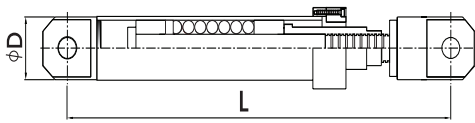

■ Features

VD20 (Vibration Friction Damper) is a pipe-type vibration and shock control device usually installed in a power generator, petrochemical plant and semi-conductor manufacturing facilities to reduce vibration in pipes by external pressure such as earthquakes and water-shock. It protects parts of the pipe line without interfering in the thermal expansion and ensures safety against external shock like an earthquake. With a special ceiling, lining and a compressed coil spring inside, it controls the dynamic load.

■ Specification

| No. | Name of Components | No. | Name of Components |
|-----|--------------------|-----|--------------------|
| 1 | Damper Body | 4 | Coil Spring |
| 2 | Clevis | 5 | Adjust Rod |
| 3 | Lining Shoe | 6 | Clevis Nut |

■ Installation example

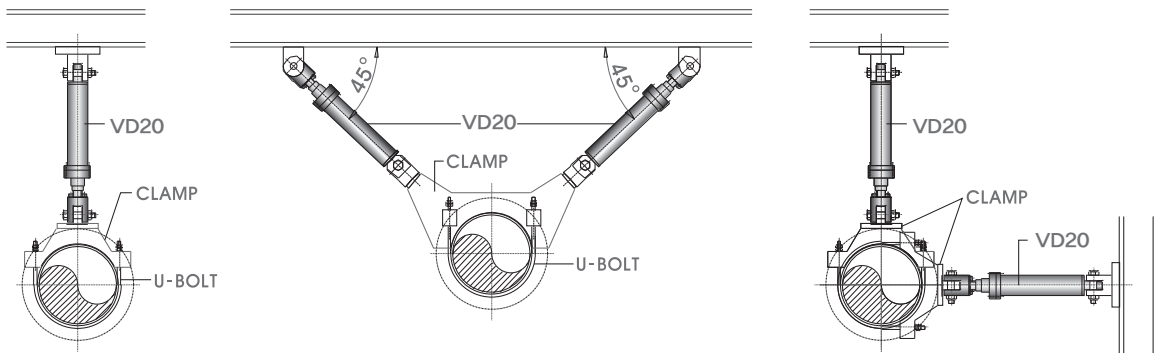

■ Dimension & Selection Guide

| Type | Outer Diameter (φD) | Stroke (mm) | Length (L) | Rod (φD) | Clevis Hole (φD) | Remark |
|-----------|---------------------|-------------|------------|----------|------------------|--|
| VD20-500 | 76.3 | 85.0 | 513 | 30 | 24 | The outer material is based on SCH #40 steel pipes for pressure service. It can be made to order |
| VD20-1000 | | | | | | |
| VD20-1500 | 90.6 | 49.3 | 644 | 40 | 30 | |
| VD20-2000 | | | | | | |

(NOTE) The mentioned size and scale can be altered to improve the quality performance and capacity of the product without any notice.

VD30 Seismic Total Damper

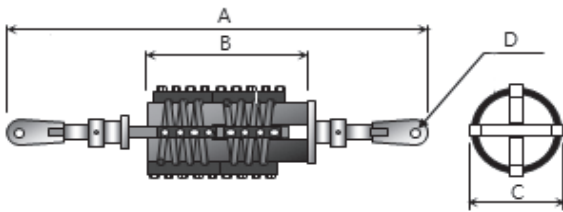
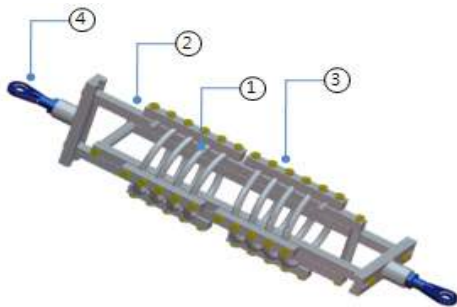
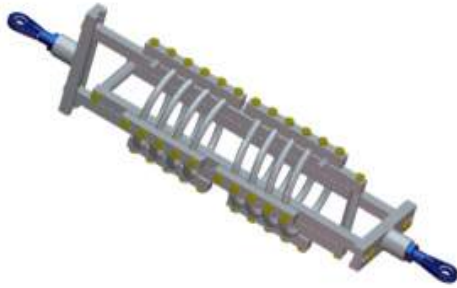

■ Features

VD30 is an effective damping device to earn stability and vibration isolation simultaneously. You can save money because there is no risk of oil leakage, no limitation mechanical service life, and no maintenance, unlike existing hydraulic or mechanical damper.

■ Specification

| No. | Name of Components | Material |
|-----|--------------------|----------|
| 1 | Wire Rope | STS304 |
| 2 | Mount Block | STS304 |
| 3 | Bolt | STS304 |
| 4 | Clevis | S45C |

■ Application

VD30 aims to isolate vibration. A fluid flow inside the pipe produced a vibration frequency, which comes close to the natural frequency of the pipe itself and then resonance occurs. Absorbing the energy from the resonance, this product stabilizes dynamic behavior of the piping system and prevents the vibration from being transmitted to the support structure.



■ Dimension & Selection Guide

| Type | Stroke(mm) | Max-Stroke Spring rate(kgf/mm) | A MIN.(mm) | B(mm) | C(mm) | D(mm) |
|------------|------------|--------------------------------|------------|-------|-------|-------|
| VD30-750 | ± 25 | 30 | 584 | 258 | 202 | 12.7 |
| | ± 12 | 63 | 559 | 232 | 121 | 12.7 |
| VD30-1500 | ± 40 | 37.5 | 762 | 357 | 294 | 12.7 |
| | ± 25 | 60 | 711 | 317 | 210 | 12.7 |
| | ± 12 | 125 | 686 | 299 | 133 | 12.7 |
| VD30-3000 | ± 50 | 60 | 914 | 459 | 399 | 19.1 |
| | ± 40 | 75 | 914 | 459 | 310 | 19.1 |
| | ± 25 | 120 | 787 | 346 | 218 | 19.1 |
| VD30-6000 | ± 50 | 120 | 1067 | 544 | 420 | 19.1 |
| | ± 40 | 150 | 1016 | 489 | 331 | 19.1 |
| | ± 25 | 240 | 1016 | 485 | 252 | 19.1 |
| VD30-12000 | ± 50 | 240 | 1270 | 660 | 466 | 25.4 |
| | ± 40 | 300 | 1194 | 577 | 375 | 25.4 |
| | ± 25 | 480 | 1168 | 572 | 305 | 25.4 |

(NOTE) The mentioned size and scale can be altered to improve the quality performance and capacity of the product without any notice.

SC Swivel Connector

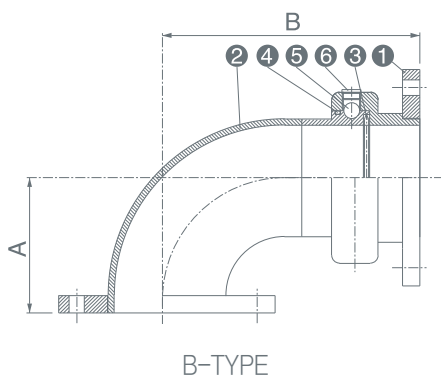
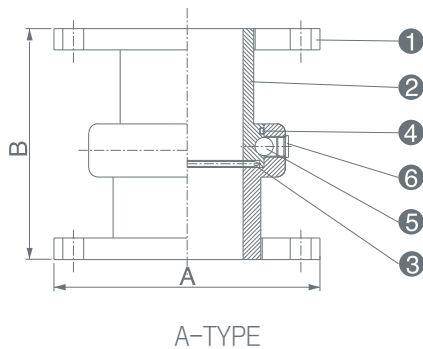
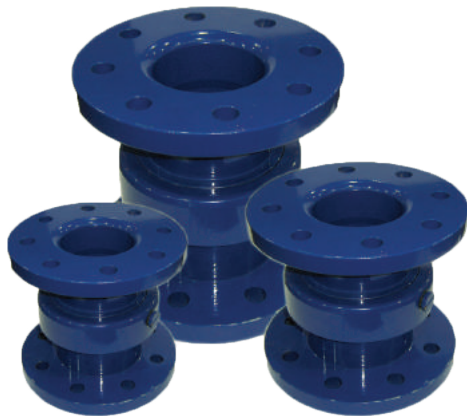

■ Features

It is called swing joint, or swivel connector, which is usually used to branch off a pipe for steam and hot-water heating systems. A low-pressure branch point is connected to more than two elbows. When one elbow is inflated, the connection gets twisted and absorbs the inflation. Type SJ-A and type SJ-B can be used to connect a turning region, minimizing moment loaded on the piping when it expands and contracts. Structural features include: 360-degree rotation due to ball bearing inside, high mechanical strength, workable under high temperature/high pressure condition.

■ Application

- ◆ Rotatable pneumatic tubing
- ◆ Hydraulic tubing
- ◆ Where rotatable motion is required in the piping system

■ Specification

| No. | Name of Components | Material | Remark |
|-----|--------------------|-------------|--|
| 1 | Flange | SS41, SS400 | Powder Coating |
| 2 | Body | S45C, SM45C | Powder Coating |
| 3 | Inner Sealing | - | (U-Type Seal Jacket + SUS Spring) Special Seal |
| 4 | External Sealing | | |
| 5 | Ball Bearing | STB, SUJ | - |
| 6 | Plug | - | - |

■ SC-A Type Dimension & Selection Guide

| Type | Dimension(mm) | | Remark |
|-----------|---------------|-----|--|
| | A | B | |
| SC-A 50A | 155 | 180 | KS B 1503-99, 10,20kgf/cm ² Flange |
| SC-A 65A | 175 | 180 | |
| SC-A 80A | 185 | 194 | |
| SC-A 100A | 210 | 194 | |
| SC-A 125A | 250 | 194 | |
| SC-A 150A | 280 | 220 | |
| SC-A 200A | 330 | 220 | |
| SC-A 250A | 400 | 260 | |
| SC-A 300A | 445 | 260 | |

(NOTE) The mentioned size and scale can be altered to improve the quality performance and capacity of the product without any notice.

■ SC-B Type Dimension & Selection Guide

| Type | Dimension(mm) | | Remark |
|-----------|---------------|-----|--|
| | A | B | |
| SC-B 50A | 70 | 133 | KS B 1503-99, 10,20kgf/cm ² Flange |
| SC-B 60A | 88 | 167 | |
| SC-B 80A | 132 | 195 | |
| SC-B 100A | 132 | 250 | |
| SC-B 125A | 161 | 306 | |
| SC-B 150A | 190 | 362 | |
| SC-B 200A | 249 | 474 | |
| SC-B 250A | 307 | 585 | |
| SC-B 300A | 366 | 697 | |

(NOTE) The mentioned size and scale can be altered to improve the quality performance and capacity of the product without any notice.

SC Swivel Connector

■ Example of application

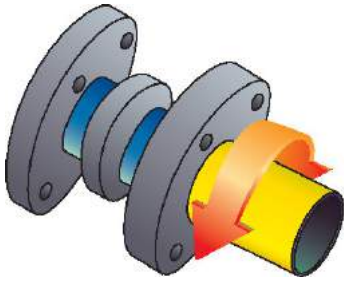

STYLE 1

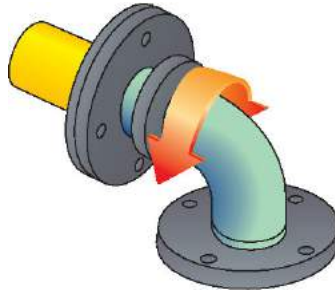

STYLE 2

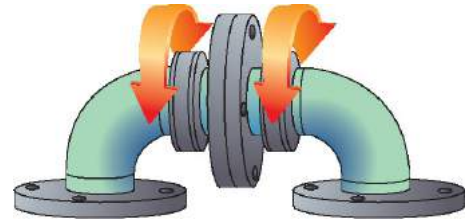

STYLE 3

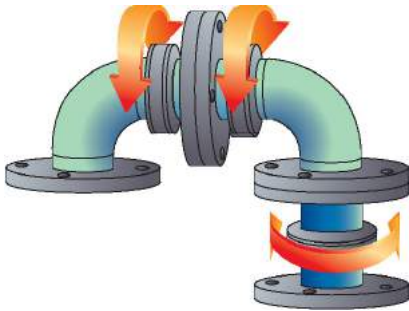

STYLE 4

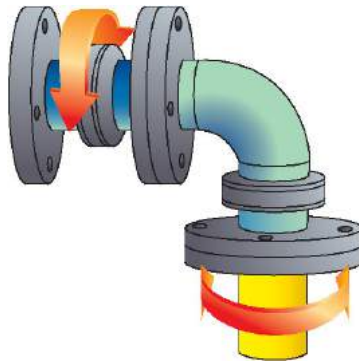

STYLE 5

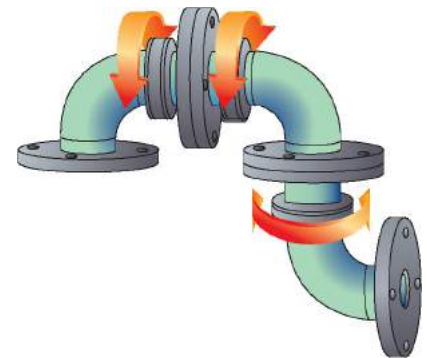

STYLE 6

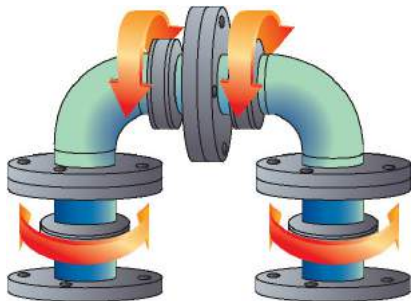

STYLE 7

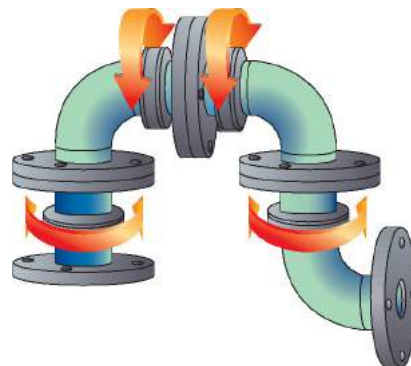

STYLE 8

WHA Water Hammer Arrester

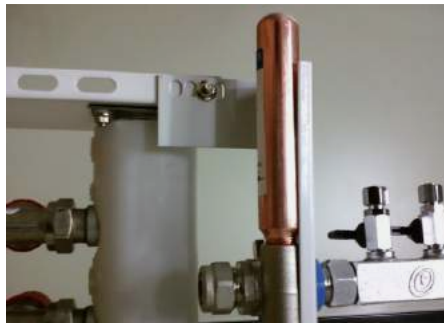

Waterhammer Analysis

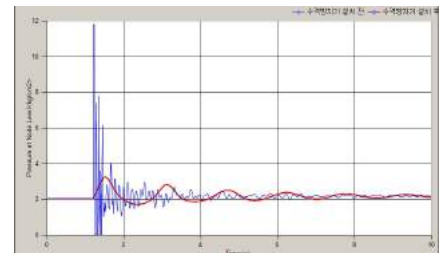
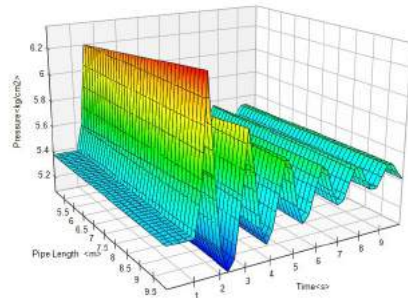
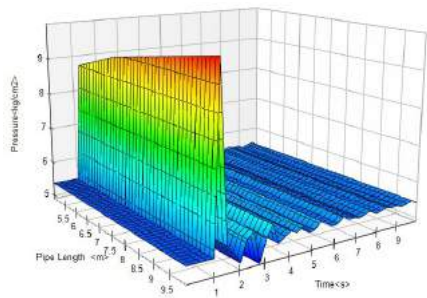

Vibration
Control



ISO 9001/ISO 14001
OHSAS 18001
MADE IN KOREA

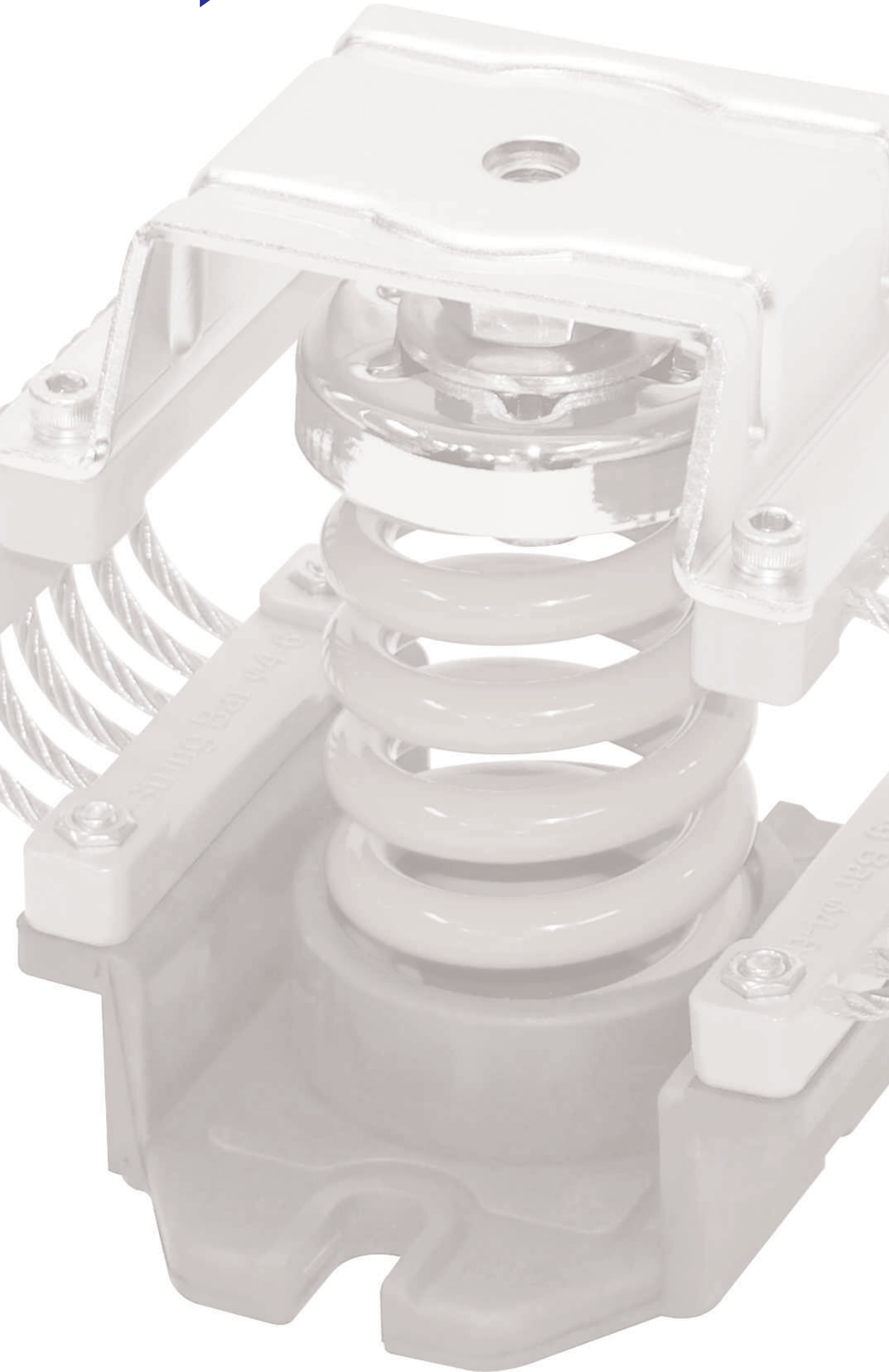

VIBRATION CONTROL

Vibration Isolation Data

Influence of Vibration

Vibration is a periodic motion when machine operates. It shortens the life of the machine itself and makes lower its performance. It also provokes psychological discomfort as well as physiological disorders. In the environmental point of view, Vibration range from 1 to 90Hz at level from 60 to 80dB is harmful.

Vibration-proof Design of Equipment

► Exciting Force

When equipment executes a rotary or reciprocating motion, vibration force is generated. This force is called by, "the exciting force". The strength and frequency of the exciting force is decided by kind, shape and capacity of the equipment.

| Features of Exciting Forces | Vibration Source | Vibration-proof Support Method |
|--------------------------------------|---|---|
| Steady vibration with High frequency | centrifugal water chiller, high-pressure pumps, high-pressure transformer, etc. | ① Vibration-proof rubber mount common bed if necessary ② Vibration-proof rubber pad, Glass wool, rock wool |
| Steady vibration with low frequency | Blowers, Pumps, water chillers, cooling towers, reciprocating equipment, etc. | ① Common bed with sufficient mass and strength, Vibration-proof rubber pads, Air-spring side support if necessary ② Vibration-proof rubber mount ③ Vibration-proof rubber pad, Glass wool, rock wool. |
| Random continuous vibration | elevators, gondolas, ducts | Vibration-proof rubber support |
| Shock | feed & waste water pipes | For low shock, a band with glass wool and rock wool |

Exciting Forces of rotating equipment is calculated by following.

$$F = mr\omega^2 = mr(2\pi f)^2$$

F: Exciting Force, r: Concentricity distance m: Mass of the machine, ω Rotational speed(rad/s) of the machine f: Rotation cycle

► Transmission Ratio

When the equipments are installed in lower stories or basements, the floor is considered to be a completely rigid body so that we can assume that 1-degree of freedom vibration system.

$$M\ddot{x} + C\dot{x} + Kx = F_0 \sin 2\pi f_d t$$

M: Mass of the machine C: damping coefficient

K: Spring constant x: Particle displacement

F₀: Amplitude of exciting force

f_d: Operating or forcing frequency of the machine. t: Time

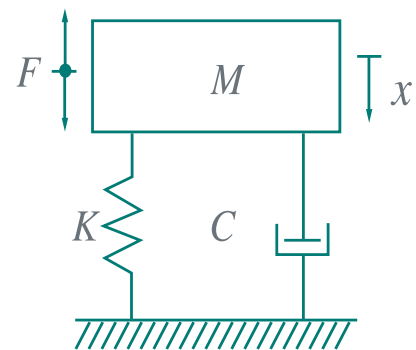

The term transmission ratio is force ratio transmitted to floor to the equipment generating exciting forces.

$$Tr = \frac{\sqrt{1 + 4\zeta^2 \times \left(\frac{f_d}{f_n}\right)^2}}{\sqrt{\left(1 - \left(\frac{f_d}{f_n}\right)^2\right)^2 + 4\zeta^2 \times \left(\frac{f_d}{f_n}\right)^2}}$$

also practically, $\zeta \approx 0$,

Tr: Vibration transmission ratio

f_n: Natural frequency

f_d: Operating or forcing frequency of the machine.

ζ: Damping ratio

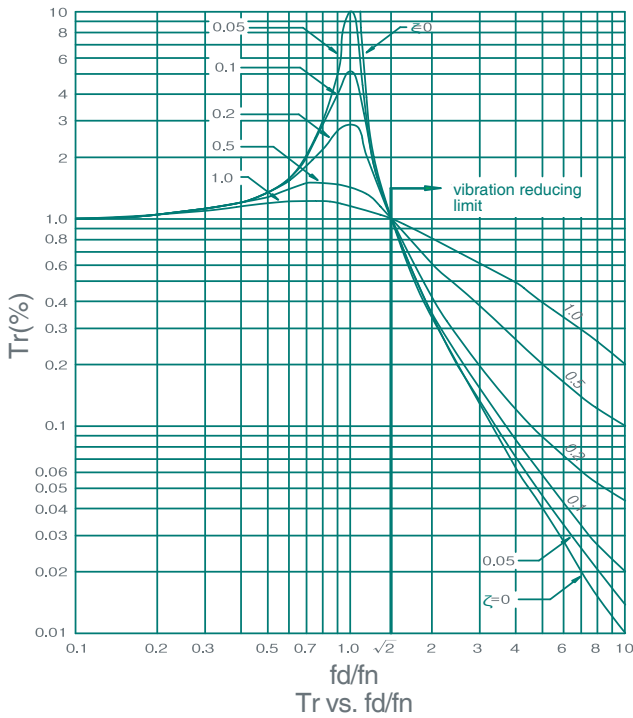

$$Tr = \frac{1}{\left| 1 - \left(\frac{fd}{fn} \right)^2 \right|}$$

frequency ratio of Tr and fd/fn is if

- fd/fn = 1, Tr = ∞ Resonance
- fd/fn < √2, Tr > 1 Transmission Force > Generating Force
- fd/fn = √2, Tr = 1 Transmission Force = Generating Force
- fd/fn > √2, Tr < 1 Transmission Force < Generating Force

► Spring constant of vibration-proofing material

Natural frequency of vibration-proofing system
 'fn' and static deflection 'δ' is expressed by following equation.

$$fn = \frac{1}{2\pi} \sqrt{\frac{K}{M}} = \frac{1}{2\pi} \sqrt{\frac{W/\delta}{W/g}} [Hz] = \sqrt{\frac{4.98}{\delta}} \therefore K = \frac{W}{\delta}$$

- K: Spring constant(kgf/mm)
- δ: static deflection(cm)
- fn: Natural frequency of vibration-proofing system(Hz)
- g: gravity acceleration 980(C m/s²)
- W: weight which each vibration-proofing material support(N)

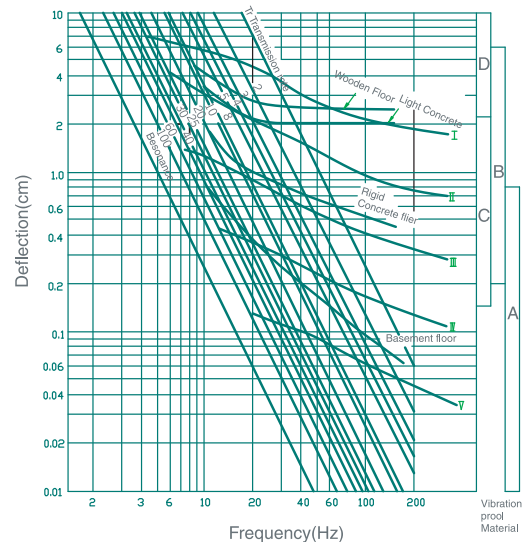

Selection Table by various floor structure

(NOTE) A: Vibration proof Rubber C: Air Spring
 B: Metal Coil Spring D: Closed Air Spring



► Allowable vibration criteria for Building [ISO]

| Area | Time | Continuous vibration acceleration amplitude | Shock acceleration amplitude |
|---|--------|---|------------------------------|
| Hospital operating room, etc Important area | Day | 0.0036(51dB) | 0.005(54dB) |
| | Night | 0.0036(51dB) | 0.005(54dB) |
| Resident area | Day | 0.072/√t (57dB) | 0.1/√n (60dB) |
| | Night | 0.005(54dB) | 0.01(60dB) |
| office | Always | 0.14/√t (63dB) | 0.2/√n (66dB) |
| Factory, Workplace | Always | 0.28/√t (69dB) | 0.4/√n (72dB) |

In this table, 't' is vibration exposure time(second). less than 100 second, vibration exposure time uses real time and if longer than 100 second, use 100 second. Shock number 'n' becomes 100, even though more than 100 and in case of under 100, use real value. The unit of vibration is vibration acceleration(m/s²) and the value in the blank to be calculated to dB unit.

Vibration Isolation Data

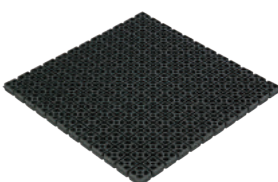
Sort of vibration isolators and characteristics

| Type | general information | performance and characteristic | Cautions | Usage |
|-----------------------|---|---|--|--|
| Steel coil springs | <p>① To isolate vibration using the elasticity of steel coil spring Normally use coil spring for HVAC system.</p> <p>② Normally use coil spring for HVAC system.</p>  | <p>〈Merit〉</p> <p>① Spring constants are clear and free choice is available</p> <p>② It's available to choose small spring constant</p> <p>〈Demerit〉</p> <p>① Resonance can be occurred once machine's on-off</p> <p>② Surging and structure borne noise can be made by spring's natural frequency once high frequency vibration</p> | <p>① Not available for noise control</p> <p>② It's available to make spring constant be small, but it makes vibration be high. Enough room must be required for machine, piping and duct system</p> | Rotary machine such as pump, motor, Fans etc. |
| Rubber pad | <p>① To isolate vibration by special uneven surface of plat-type rubber pad material</p> <p>② This is macroscopically one of the rubber mount</p>  | <p>〈Merit〉</p> <p>Easy installation and cheap price</p> <p>〈Demerit〉</p> <p>Vibration isolation is ineffective for low frequency because it's not available for making spring constant be small. Vibration isolation efficiency is limited</p> | <p>① To use steel plate between rubber pads once using more than 2 layers rubber pads.</p> <p>② To consider it's chemical characteristics</p> | To be effective for high frequency vibration such as, chiller and AHU etc. |
| rubber mounts/rangers | <p>① To be made of NR or CR with reasonable hardness. It's available for forming with steel insert and using elasticity of rubber.</p> <p>② To be assorted as pressed type, sheared type and complex type, based on sort of impact to the mount, circular type, rectangular type, cylinder type and mountain type based on the features.</p> <p>③ Pressed type is widely used because load capacity is high per unit area. Sheared type is used for small load capacity and low frequency machine because it has got small spring constant.</p> <p>④ Complex type is used for the application which is impacted by 3 ways(direction X,Y and Z) loads at once.</p>  <p>Pressed type Sheared type</p> <p>Complex type-1 Complex type-2</p> | <p>〈merit〉</p> <p>① To choose features freely and reasonably select spring constant ratio for X,Y and Z direction</p> <p>② Resonance is reduced by it's viscosity.</p> <p>③ Surging is reduced and noise absorption is available.</p> <p>④ A lot of standard products</p> <p>〈Demerit〉</p> <p>① To pay attention to use at temperature condition between 10~70°C because spring constant can be changeable based on temperature change</p> <p>② Spring constant can be also changeable based on rubber's modify.</p> <p>③ Small spring constant is not available</p> <p>④ Chemical characteristics are flexible for each sort of rubber materials</p> <p>⑤ It's too hard to know exact spring constant because static spring constant and dynamic spring constant are different by viscosity and elasticity</p> | <p>① To pay attention to chemical characteristics of rubber materials</p> <p>② Dynamic spring constant must be used on noise and vibration design by rubber mount.</p> <p>③ Rubber mount must be used under it's load capacity</p> <p>④ Load capacity is limited based on the degree of modification.</p> <p>⑤ Detailed specification must be provided on technical data or catalog served by manufacture.</p> | Normally used for HVAC system such as, piping and duct work etc. |

Selection Guide for Vibration Isolation, ASHRAE HANDBOOK 2011

| Equipment Type | Shaft Power kW and Other | RPM | Equipment Location (Note 1) | | | | | | | | | | Reference Notes | | |
|---|--------------------------|------------|-----------------------------|----------------|--------------------|----------------|--------------------|----------------|--------------------|----------------|------|-----------------------|-----------------|----------|-------------|
| | | | Slab on Grade | | Floor Span | | | | | | | | | | |
| | | | Base Isolator Type | Min. Defl., mm | Up to 6 m | | 6 to 9 m | | 9 to 12 m | | | | | | |
| | | | | | Base Isolator Type | Min. Defl., mm | Base Isolator Type | Min. Defl., mm | Base Isolator Type | Min. Defl., mm | | | | | |
| Refrigeration Machines and Chillers | | | | | | | | | | | | | | | |
| Reciprocating | All | All | A | 2 | 6.4 | A | 4 | 19 | A | 4 | 38 | A | 4 | 64 | 2,3,12 |
| Centrifugal, scroll | All | All | A | 1 | 6.4 | A | 4 | 19 | A | 4 | 38 | A | 4 | 38 | 2,3,4,8, 12 |
| Screw | All | All | A | 1 | 25 | A | 4 | 38 | A | 4 | 64 | A | 4 | 64 | 2,3,4,12 |
| Absorption | All | All | A | 1 | 6.4 | A | 4 | 19 | A | 4 | 38 | A | 4 | 38 | |
| Air-cooled recip., scroll | All | All | A | 1 | 6.4 | A | 4 | 38 | A | 4 | 38 | A | 4 | 64 | 2,4,5,12 |
| Air-cooled screw | All | All | A | 4 | 25 | A | 4 | 38 | B | 4 | 64 | B | 4 | 64 | 2,4,5,8,12 |
| Air Compressors and Vacuum Pumps | | | | | | | | | | | | | | | |
| Tank-mounted horiz. | ≤7.5 | All | A | 3 | 19 | A | 3 | 19 | A | 3 | 38 | A | 3 | 38 | 3,15 |
| | ≥11 | All | C | 3 | 19 | C | 3 | 19 | C | 3 | 38 | C | 3 | 38 | 3,15 |
| Tank-mounted vert. | All | All | C | 3 | 19 | C | 3 | 19 | C | 3 | 38 | C | 3 | 38 | 3,15 |
| Base-mounted | All | All | C | 3 | 19 | C | 3 | 19 | C | 3 | 38 | C | 3 | 38 | 3,14,15 |
| Large reciprocating | All | All | C | 3 | 19 | C | 3 | 19 | C | 3 | 38 | C | 3 | 38 | 3,14,15 |
| Pumps | | | | | | | | | | | | | | | |
| Close-coupled | ≤5.6 | All | B | 2 | 6.4 | C | 3 | 19 | C | 3 | 19 | C | 3 | 19 | 16 |
| | ≥7.5 | All | C | 3 | 19 | C | 3 | 19 | C | 3 | 38 | C | 3 | 38 | 16 |
| Large inline | 3.7 to 19 | All | A | 3 | 19 | A | 3 | 38 | A | 3 | 38 | A | 3 | 38 | |
| | ≥22 | All | A | 3 | 38 | A | 3 | 38 | A | 3 | 38 | A | 3 | 64 | |
| End suction and split case | ≤30 | All | C | 3 | 19 | C | 3 | 19 | C | 3 | 38 | C | 3 | 38 | 16 |
| | 37 to 93 | All | C | 3 | 19 | C | 3 | 19 | C | 3 | 38 | C | 3 | 64 | 10,16 |
| | ≥110 | All | C | 3 | 19 | C | 3 | 38 | C | 3 | 64 | C | 3 | 89 | 10,16 |
| Packaged pump systems | All | All | A | 3 | 19 | A | 3 | 19 | A | 3 | 38 | C | 3 | 64 | |
| Cooling Towers | | | | | | | | | | | | | | | |
| | All | Up to 300 | A | 1 | 6.4 | A | 4 | 89 | A | 4 | 89 | A | 4 | 89 | 5,8,18 |
| | | 301 to 500 | A | 1 | 6.4 | A | 4 | 64 | A | 4 | 64 | A | 4 | 64 | 5,18 |
| | | 501 and up | A | 1 | 6.4 | A | 4 | 19 | A | 4 | 19 | A | 4 | 38 | 5,18 |
| Boilers | | | | | | | | | | | | | | | |
| Fire-tube | All | All | A | 1 | 6.4 | B | 4 | 19 | B | 4 | 38 | B | 4 | 64 | 4 |
| Water-tube, copper fin | All | All | A | 1 | 3 | A | 1 | 3 | A | 1 | 3 | B | 4 | 6.4 | |
| Axial Fans, Plenum Fans, Cabinet Fans, Fan Sections, Centrifugal Inline Fans | | | | | | | | | | | | | | | |
| Up to 560 mm diameter | All | All | A | 2 | 6.4 | A | 3 | 19 | A | 3 | 19 | C | 3 | 19 | 4,9 |
| 610 mm diameter and up | ≤500 Pa SP | Up to 300 | B | 3 | 64 | C | 3 | 89 | C | 3 | 89 | C | 3 | 89 | 9,8 |
| | | 300 to 500 | B | 3 | 19 | B | 3 | 38 | C | 3 | 64 | C | 3 | 64 | 9,8 |
| | | 501 and up | B | 3 | 19 | B | 3 | 38 | B | 3 | 38 | B | 3 | 38 | 9,8 |
| | ≥501 Pa SP | Up to 300 | C | 3 | 64 | C | 3 | 89 | C | 3 | 89 | C | 3 | 89 | 3,8,9 |
| | | 300 to 500 | C | 3 | 38 | C | 3 | 38 | C | 3 | 64 | C | 3 | 64 | 3,8,9 |
| | | 501 and up | C | 3 | 19 | C | 3 | 38 | C | 3 | 38 | C | 3 | 64 | 3,8,9 |
| Centrifugal Fans | | | | | | | | | | | | | | | |
| Up to 560 mm diameter | All | All | B | 2 | 6.4 | B | 3 | 19 | B | 3 | 19 | B | 3 | 38 | 9,19 |
| 610 mm diameter and up | ≤30 | Up to 300 | B | 3 | 64 | B | 3 | 89 | B | 3 | 89 | B | 3 | 89 | 8,19 |
| | | 300 to 500 | B | 3 | 38 | B | 3 | 38 | B | 3 | 64 | B | 3 | 64 | 8,19 |
| | | 501 and up | B | 3 | 19 | B | 3 | 19 | B | 3 | 19 | B | 3 | 38 | 8,19 |
| | ≥37 | Up to 300 | C | 3 | 64 | C | 3 | 89 | C | 3 | 89 | C | 3 | 89 | 2,3,8,9,19 |
| | | 300 to 500 | C | 3 | 38 | C | 3 | 38 | C | 3 | 64 | C | 3 | 64 | 2,3,8,9,19 |
| | | 501 and up | C | 3 | 25.4 | C | 3 | 38 | C | 3 | 38 | C | 3 | 64 | 2,3,8,9,19 |
| Propeller Fans | | | | | | | | | | | | | | | |
| Wall-mounted | All | All | A | 1 | 6.4 | A | 1 | 6.4 | A | 1 | 6.4 | A | 1 | 6.4 | |
| Roof-mounted | All | All | A | 1 | 6.4 | A | 1 | 6.4 | B | 4 | 38 | D | 4 | 38 | |
| Heat Pumps, Fan-Coils, Computer Room Units | | | | | | | | | | | | | | | |
| Condensing Units | All | All | A | 1 | 6.4 | A | 4 | 19 | A | 4 | 38 | A/D | 4 | 38 | |
| Packaged AH, AC, H and V Units | | | | | | | | | | | | | | | |
| All | ≤7.5 | All | A | 3 | 19 | A | 3 | 19 | A | 3 | 19 | A | 3 | 19 | 19 |
| | ≤11 | Up to 300 | A | 3 | 19 | A | 3 | 89 | A | 3 | 89 | C | 3 | 89 | 2,4,8,19 |
| | ≤1 kPa SP | 301 to 500 | A | 3 | 19 | A | 3 | 64 | A | 3 | 64 | A | 3 | 64 | 4,19 |
| | | 501 and up | A | 3 | 19 | A | 3 | 38 | A | 3 | 38 | A | 3 | 38 | 4,19 |
| | >1 kPa SP11, | Up to 300 | B | 3 | 19 | C | 3 | 89 | C | 3 | 89 | C | 3 | 89 | 2,3,4,8,9 |
| | >1 kPa SP | 301 to 500 | B | 3 | 19 | C | 3 | 38 | C | 3 | 64 | C | 3 | 64 | 2,3,4,9 |
| | | 501 and up | B | 3 | 19 | C | 3 | 38 | C | 3 | 38 | C | 3 | 64 | 2,3,4,9 |
| Packaged Rooftop Equipment | | | | | | | | | | | | | | | |
| | All | All | A/D | 1 | 6.4 | D | 3 | 19 | | | | See Reference Note 17 | | 5,6,8,17 | |
| Ducted Rotating Equipment | | | | | | | | | | | | | | | |
| Small fans, fan-powered boxes | ≤300 L/s | All | A | 3 | 12.7 | A | 3 | 12.7 | A | 3 | 12.7 | A | 3 | 12.7 | 7 |
| | ≥301 L/s | All | A | 3 | 19 | A | 3 | 19 | A | 3 | 19 | A | 3 | 19 | 7 |
| Engine-Driven Generators | | | | | | | | | | | | | | | |
| | All | All | A | 3 | 19 | C | 3 | 38 | C | 3 | 64 | C | 3 | 89 | 2,3,4 |

Piping and Ducts (See sections on Isolating Vibration and Noise in Piping Systems and Isolating Duct Vibration for isolator selection.)

► BASE TYPE

- A. No Base B. Structural steel rails or base

isolators attached directly to equipment

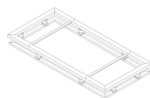

- C. Concrete inertia base D. Curb-mounted base

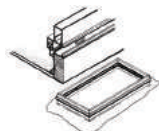
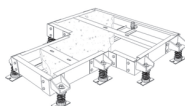

► ISOLATOR TYPE

RUBBER PADS (TYPE 1)

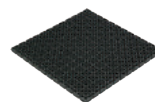

RUBBER MOUNTS (TYPE 2)



SPRING ISOLATOR (TYPE 3)



RESTRAINED SPRING ISOLATOR (TYPE 4)



THRUST RESTRAINT (TYPE 5)



SMA Spring Mount (Deflection : 25mm)

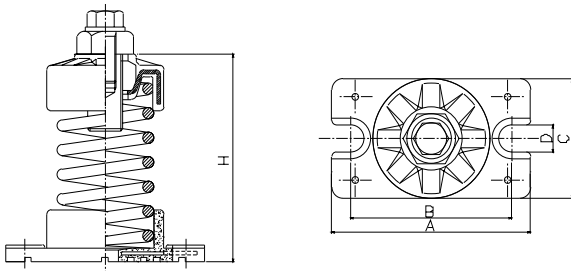
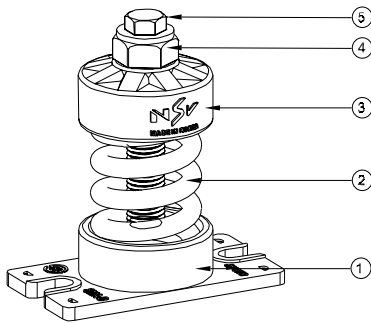

■ Features

An open-spring mount is, in general, used together with the additional load base. It is easy to install and check; also its static deflection is visible to the naked eye. The spring is in between the upper cap and the bottom cap without any guide, and the bottom cap is mounted with the base plate having a hole for the anchor bolt. Plus, the steel plate is inserted inside the cap and at the top of the mount, there is a level-control bolt made up of the control bolt, cap, screw and washer. There is also a drain hole inside the bottom base, which facilitates drainage.

■ Usage

- ◆ For pump vibration isolator stand
- ◆ For ventilator
- ◆ For air conditioning units
- ◆ For equipment having a small horizontal reaction

■ Specification

| No. | Name of Components | Material | Standard |
|-----|-----------------------------|----------|-----------|
| 1 | Lower Spring Cap Base Plate | CR | KS M 6617 |
| | | SS400 | KS D 3503 |
| 2 | Coil Spring | SUP9 | KS B 2402 |
| | | HSW3 | KS B 2403 |
| 3 | Upper Spring Cap | CR | KS M 6617 |
| | | SS400 | KS D 3503 |
| 4 | Level Bolt | SS400 | KS B 1002 |
| 5 | Cap Screw | SS400 | KS B 1002 |

■ Dimension & Selection Guide

| Type | Capacity (kgf) | Spring Constant (kgf/mm) | Weight (kg) | Color | Dimension(mm) | | | | | | |
|------------|----------------|--------------------------|-------------|--------|---------------|-----|----|----|-----|------------|-----------|
| | | | | | A | B | C | D | H | Level Bolt | Cap Screw |
| SMA-A-50 | 50 | 2.0 | 0.35 | Red | 90 | 74 | 53 | 12 | 94 | M16 × 45 | M10 × 25 |
| SMA-A-75 | 75 | 3.0 | 0.39 | Black | | | | | | | |
| SMA-A-100 | 100 | 4.0 | 0.41 | Blue | | | | | | | |
| SMA-B-100 | 100 | 4.0 | 1.10 | Blue | 130 | 100 | 70 | 13 | 128 | M20 × 90 | M12 × 25 |
| SMA-B-150 | 150 | 6.0 | 1.12 | Brown | | | | | | | |
| SMA-B-200 | 200 | 8.0 | 1.18 | White | | | | | | | |
| SMA-B-300 | 300 | 12.0 | 1.34 | Orange | | | | | | | |
| SMA-B-400 | 400 | 16.0 | 1.34 | Pink | | | | | | | |
| SMA-C-400 | 400 | 16.0 | 1.90 | Pink | | | | | | | |
| SMA-C-500 | 500 | 20.0 | 2.00 | Green | 150 | 120 | 84 | 13 | 144 | M20 × 90 | M12 × 25 |
| SMA-C-600 | 600 | 24.0 | 2.08 | Blue | | | | | | | |
| SMA-C-750 | 750 | 30.0 | 2.12 | Black | | | | | | | |
| SMA-C-1000 | 1000 | 40.0 | 2.32 | Yellow | | | | | | | |
| SMA-C-1200 | 1200 | 48.0 | 2.20 | Red | | | | | | | |

(NOTE) The mentioned size and scale can be altered to improve the quality performance and capacity of the product without any notice.

SMA Spring Mount (Deflection : 25mm)

■ SMA Test Data

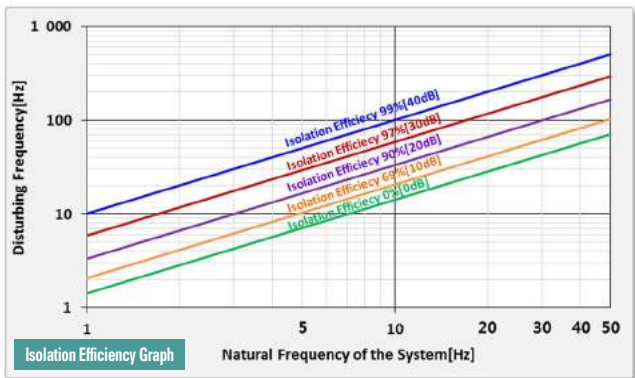
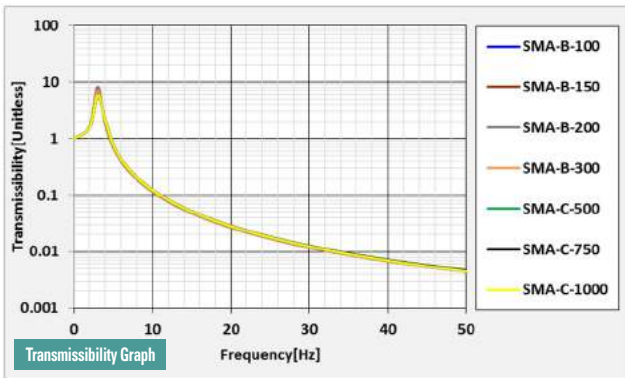
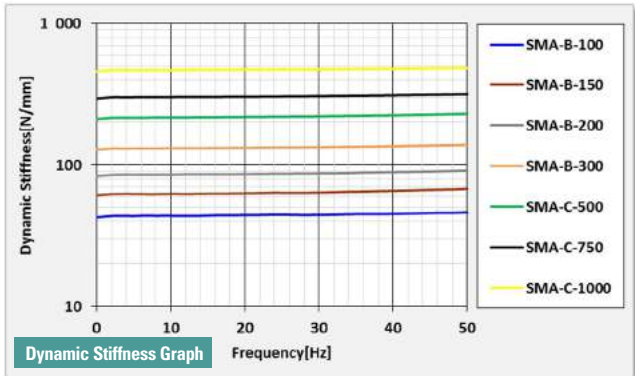
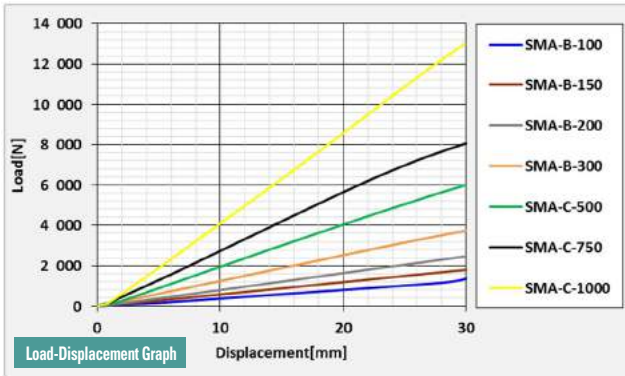

■ Installation Features

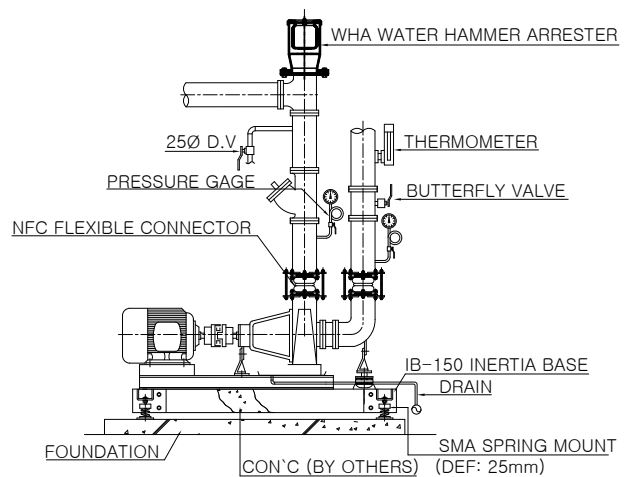
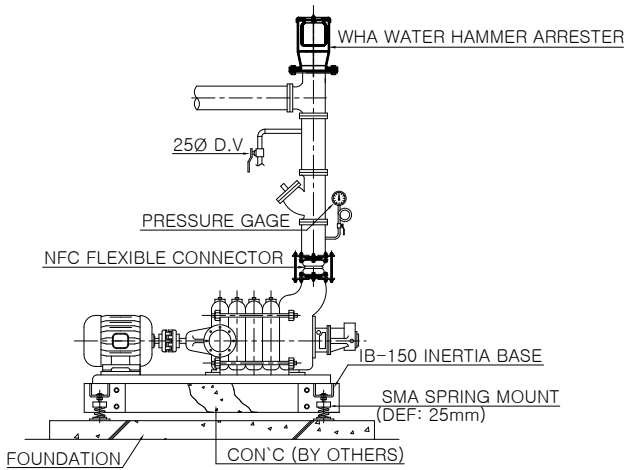

2SMA Spring Mount (Deflection : 25mm)

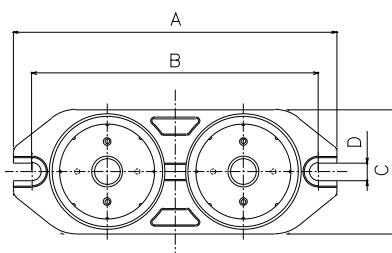
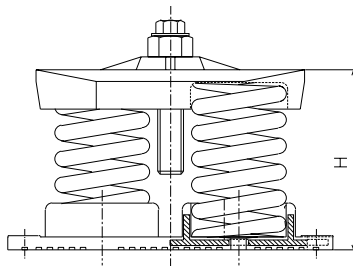
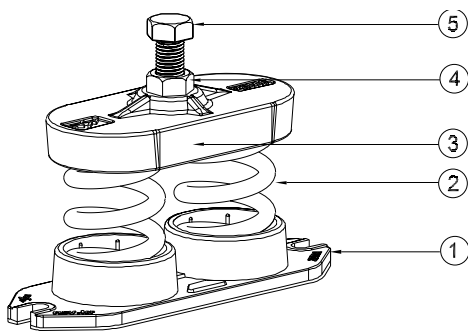

■ Features

Open spring mount is, in general, used together with an additional load base. Not only is it easy to install, but it also it a static deflection visible to the naked eye. It is excellent in reducing vibration with left-right and up-down stability. Its upper/bottom housings are made of castings with 2ea mounted springs. Because it is open-type, it can be used to reduce the vibrations that heavy equipment creates without having to use too many.

■ Usage

- ◆ For pumps (single-stage and multi-stage, turbine, double suction types)
- ◆ For air conditioning units (horizontal, vertical, hybrid, built-in, detachable, etc)
- ◆ For ventilators (sirocco, air-foil, turbo double suction and single suction types, etc)
- ◆ For all kinds of vibrating objects

■ Specification

| No. | Name of Components | Material | Standard |
|-----|--------------------|----------|-----------|
| 1 | Rubber Housing | CR | KS M 6617 |
| 2 | Coil Spring | SUP9 | KS B 2402 |
| | | HSW3 | KS B 2403 |
| 3 | Upper Spring Cap | GC | KS D 4301 |
| 4 | Level Bolt | SS400 | KS B 1002 |
| 5 | Cap Screw | SS400 | KS B 1002 |

■ Dimension & Selection Guide

| Type | Capacity (kgf) | Spring Constant (kgf/mm) | Weight (kg) | Color | Dimension(mm) | | | | | | |
|-----------|----------------|--------------------------|-------------|--------|---------------|-----|----|----|-----|------------|-----------|
| | | | | | A | B | C | D | H | Level Bolt | Cap Screw |
| 2SMA-1000 | 1,000 | 40.0 | 7.36 | Green | 252 | 223 | 97 | 14 | 162 | M20 × 90 | M12 × 25 |
| 2SMA-1200 | 1,200 | 48.0 | 7.52 | Blue | | | | | | | |
| 2SMA-1500 | 1,500 | 60.0 | 7.68 | Black | | | | | | | |
| 2SMA-2000 | 2,000 | 80.0 | 8.04 | Yellow | | | | | | | |
| 2SMA-2400 | 2,400 | 96.0 | 8.12 | Red | | | | | | | |

(NOTE) The mentioned size and scale can be altered to improve the quality performance and capacity of the product without any notice.

2SMA Spring Mount (Deflection : 25mm)

2SMA Test Data

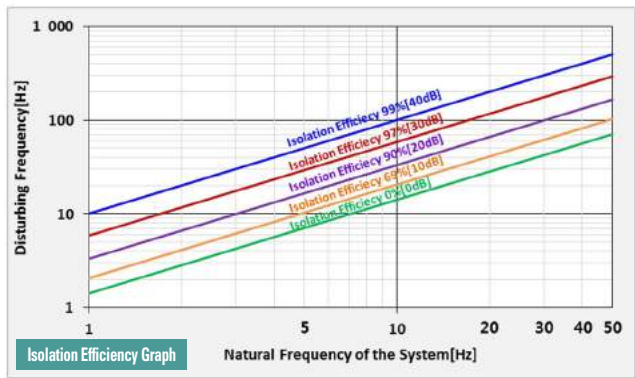
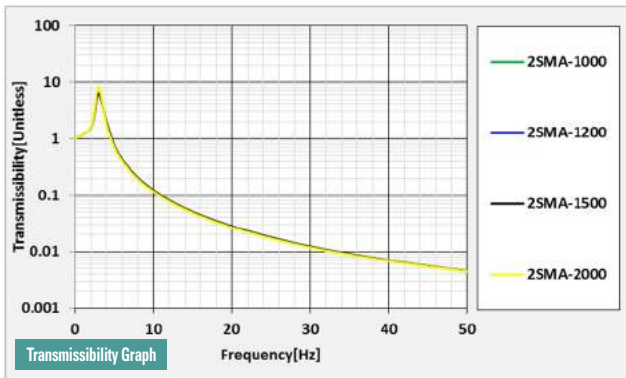
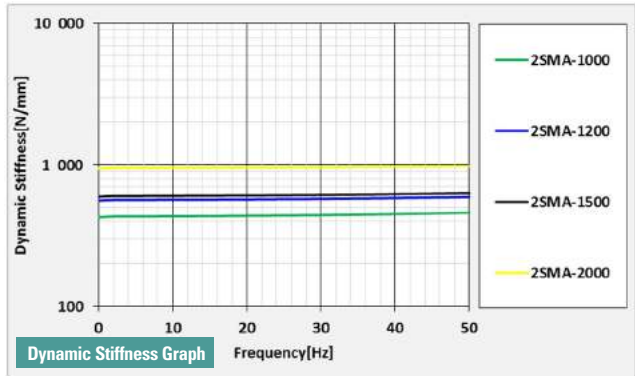
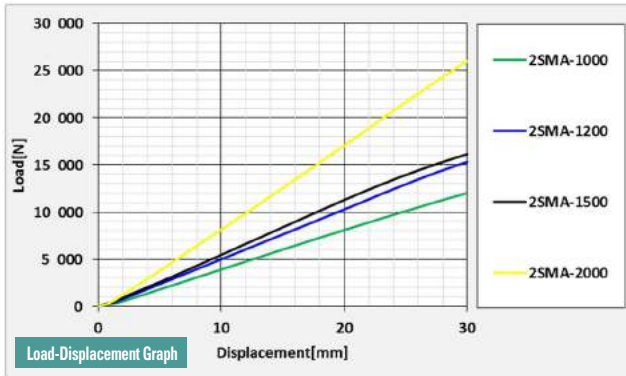

Installation Features

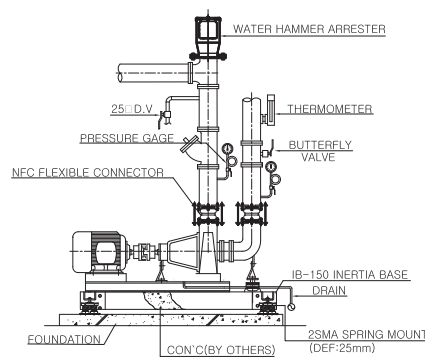

SINGLE VOLUTE PUMP DETAIL

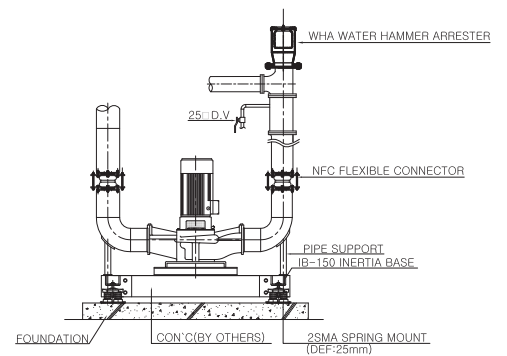

IN-LINE PUMP DETAIL



SMA2 Spring Mount (Deflection : 50mm)

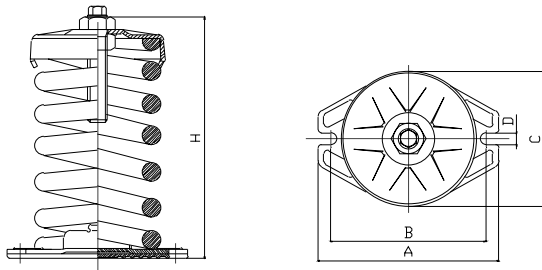
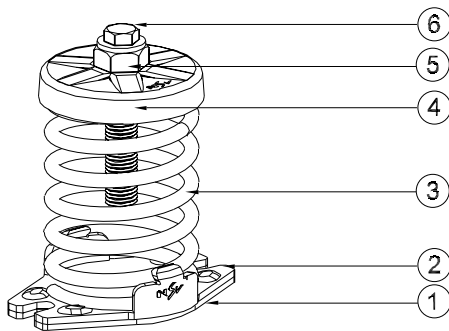

■ Features

As an open-spring mount, it is usually used together with the inertia base. It is easy to install and has a static deflection that is visible to the naked eye, which facilitates inspection after installation. It has the same components as SMA type, but has a static deflection of 50 mm, and therefore, it is used when operation of equipment needs to be quieter, such as when air conditioners and fans are installed on the ground level within the building. The top cap is made of SS400 steel plate, and it can be welded to the bottom structure, when it is made of steel, like the H-beam, without making an extra hole for installation. There is a CR-type pad attached on the base plate for a slip-resistant and high-frequency isolation.

■ Usage

- ◆ For standing pipes
- ◆ For high-efficient vibration control of ventilators (ground level)
- ◆ For high-efficient vibration control of air conditioning units (ground level)
- ◆ For high-efficient vibration control of equipment that needs to be kept quiet

■ Specification

| No. | Name of Components | Material | Standard |
|-----|--------------------|----------|-----------|
| 1 | Non Skid Pad | CR | KS M 6617 |
| 2 | Lower Housing | SS400 | KS D 3503 |
| 3 | Coil Spring | SUP9 | KS B 2402 |
| | | HSW3 | KS B 2403 |
| 4 | Upper Spring Cap | SS400 | KS D 3503 |
| 5 | Level Bolt | SS400 | KS B 1002 |
| 6 | Cap Screw | SS400 | KS B 1002 |

■ Dimension & Selection Guide

| Type | Capacity (kgf) | Spring Constant (kgf/mm) | Weight (kg) | Color | Dimension(mm) | | | | | | |
|-------------|----------------|--------------------------|-------------|--------|---------------|-----|-----|----|-----|------------|-----------|
| | | | | | A | B | C | D | H | Level Bolt | Cap Screw |
| SMA2-A-100 | 100 | 2.0 | 2.00 | Blue | 150 | 123 | 106 | 14 | 172 | M20 × 90 | M12 × 25 |
| SMA2-A-150 | 150 | 3.0 | 2.00 | Brown | | | | | | | |
| SMA2-A-200 | 200 | 4.0 | 2.04 | White | | | | | | | |
| SMA2-A-300 | 300 | 6.0 | 2.18 | Orange | | | | | | | |
| SMA2-A-400 | 400 | 8.0 | 2.46 | Pink | | | | | | | |
| SMA2-A-500 | 500 | 10.0 | 3.25 | Green | | | | | | | |
| SMA2-A-600 | 600 | 12.0 | 3.34 | Blue | | | | | | | |
| SMA2-A-750 | 750 | 15.0 | 3.08 | Black | | | | | | | |
| SMA2-A-1000 | 1000 | 20.0 | 3.38 | Yellow | | | | | | | |
| SMA2-B-1200 | 1200 | 24.0 | 7.60 | Red | | | | | | | |
| SMA2-B-1500 | 1500 | 30.0 | 7.62 | Black | | | | | | | |
| SMA2-B-1800 | 1800 | 36.0 | 7.12 | Blue | | | | | | | |
| SMA2-B-2000 | 2000 | 40.0 | 8.90 | Yellow | | | | | | | |
| SMA2-B-2500 | 2500 | 50.0 | 11.6 | Brown | | | | | | | |
| SMA2-B-3000 | 3000 | 60.0 | 12.6 | White | | | | | | | |
| SMA2-C-3500 | 3500 | 70.0 | 13.4 | Black | 214 | 184 | 162 | 14 | 289 | M24 × 110 | M12 × 40 |
| SMA2-C-4000 | 4000 | 80.0 | 13.4 | Orange | | | | | | | |

(NOTE) The mentioned size and scale can be altered to improve the quality performance and capacity of the product without any notice.

SMA2 Spring Mount (Deflection : 50mm)

■ SMA2 Test Data

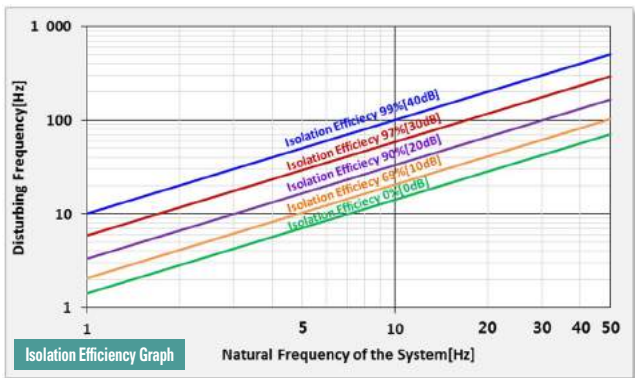
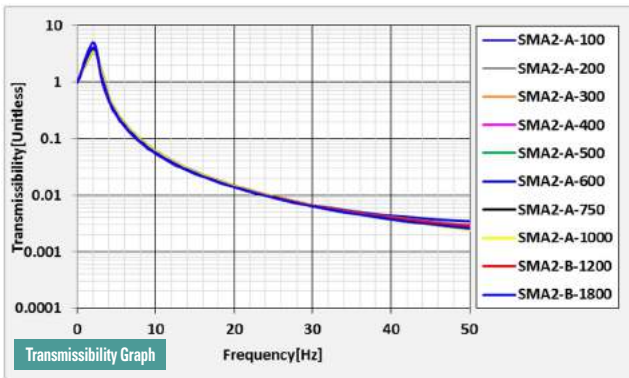
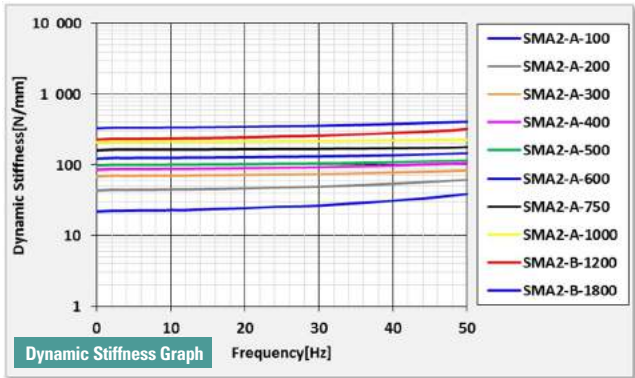
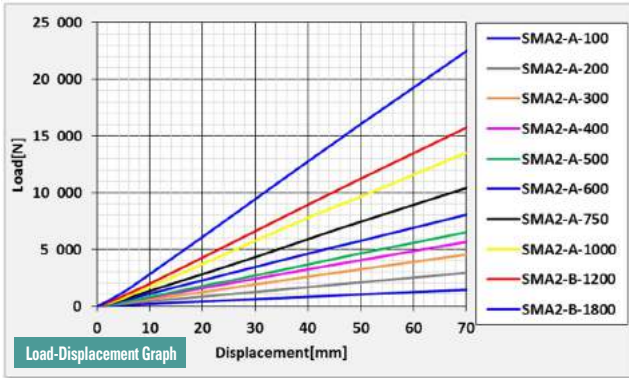

■ Installation Features

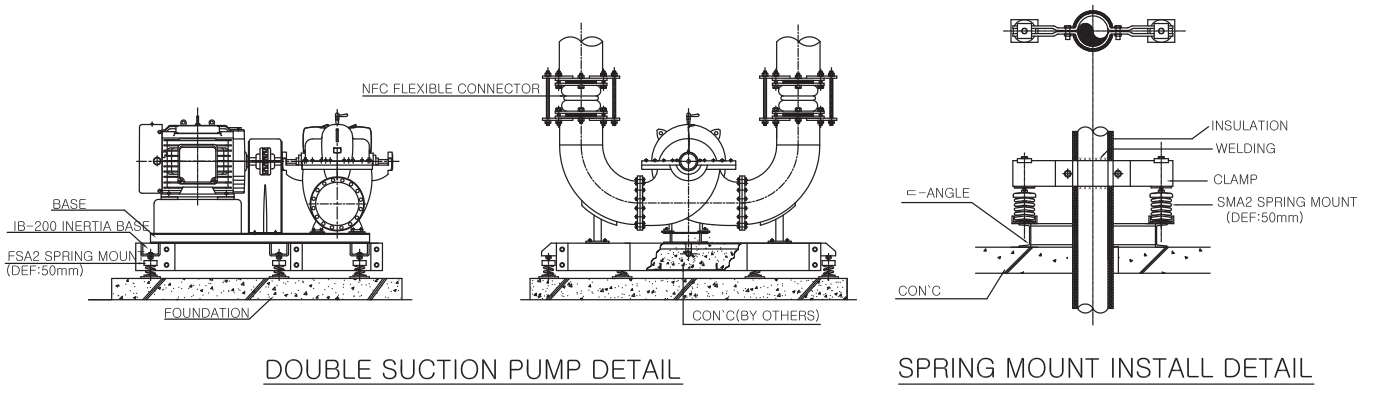

SMB Spring Mount (Deflection : 25mm)



D-TYPE

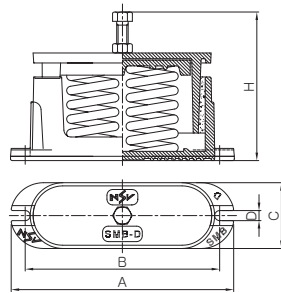
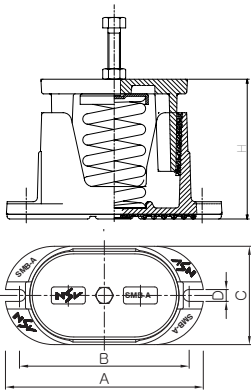
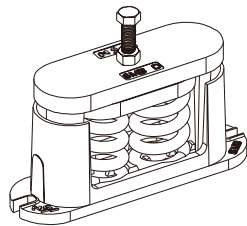
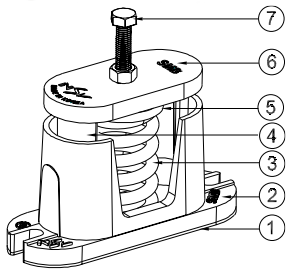

■ Features

As an enclosed spring mount, it has the spring between upper and bottom housings. An anchor hole is on the bottom housing and the tap is on the top housing, which allows level control of the bolt with a level bolt and nut to be used. Plus, the spring cap with a bolt guided hole is at the top of the spring to distribute the load transferred from the level bolt and the anti-frictioner is attached between upper and bottom housings, which somewhat reduces attenuation and friction caused by left-right and top-down relative displacement when the equipment is running. There is a CR pad attached on the bottom of the bottom housing to compensate disadvantages of the spring transferring high frequency due to a kind of surging effect.

■ Usage

- ◆ For pumps, refrigerators, compressors and power generators
- ◆ For ventilators
- ◆ For air conditioning units
- ◆ For equipment with a large horizontal reaction

■ Specification

| No. | Name of Components | Material | Standard |
|-----|--------------------|----------|-----------|
| 1 | Non Skid Pad | CR | KS M 6617 |
| 2 | Lower Housing | GC | KS D 4301 |
| 3 | Coil Spring | SUP9 | KS B 2402 |
| | | HSW3 | KS B 2403 |
| 4 | Anti-Frictioner | SvNGE | - |
| 5 | Spring Cap | SS400 | KS D 3503 |
| 6 | Upper Housing | GC | KS D 4301 |
| 7 | Level Bolt | SS400 | KS B 1002 |

■ Dimension & Selection Guide

| Type | Capacity (kgf) | Spring Constant (kgf/mm) | Weight (kg) | Color | Dimension(mm) | | | | | |
|------------|----------------|--------------------------|-------------|--------|---------------|-----|----|----|-----|------------|
| | | | | | A | B | C | D | H | Level Bolt |
| SMB-A-10 | 10 | 0.4 | 1.16 | Pink | 139 | 117 | 55 | 12 | 102 | M10 × 60 |
| SMB-A-25 | 25 | 1.0 | 1.20 | Yellow | | | | | | |
| SMB-A-50 | 50 | 2.0 | 1.34 | Red | | | | | | |
| SMB-A-75 | 75 | 3.0 | 1.34 | Black | | | | | | |
| SMB-A-100 | 100 | 4.0 | 1.30 | Blue | | | | | | |
| SMB-B-100 | 100 | 4.0 | 3.64 | Blue | 205 | 170 | 76 | 13 | 135 | M12 × 65 |
| SMB-B-150 | 150 | 6.0 | 3.64 | Brown | | | | | | |
| SMB-B-200 | 200 | 8.0 | 3.70 | White | | | | | | |
| SMB-B-300 | 300 | 12.0 | 3.94 | Orange | | | | | | |
| SMB-B-400 | 400 | 16.0 | 3.86 | Pink | | | | | | |
| SMB-C-400 | 400 | 16.0 | 5.10 | Pink | 228 | 205 | 90 | 13 | 150 | M16 × 80 |
| SMB-C-500 | 500 | 20.0 | 6.00 | Green | | | | | | |
| SMB-C-600 | 600 | 24.0 | 6.06 | Blue | | | | | | |
| SMB-C-750 | 750 | 30.0 | 6.14 | Black | | | | | | |
| SMB-C-1000 | 1000 | 40.0 | 6.32 | Yellow | | | | | | |
| SMB-D-1200 | 1200 | 48.0 | 13.38 | Blue | 306 | 277 | 94 | 14 | 170 | M16 × 80 |
| SMB-D-1500 | 1500 | 60.0 | 13.54 | Black | | | | | | |
| SMB-D-2000 | 2000 | 80.0 | 13.88 | Yellow | | | | | | |

(NOTE) The mentioned size and scale can be altered to improve the quality performance and capacity of the product without any notice.

SMB Spring Mount (Deflection : 25mm)

■ SMB Test Data

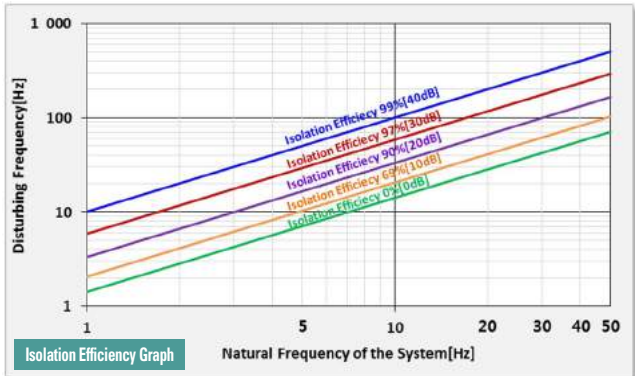
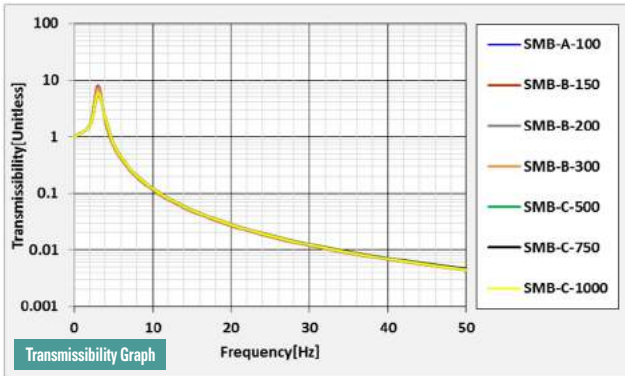
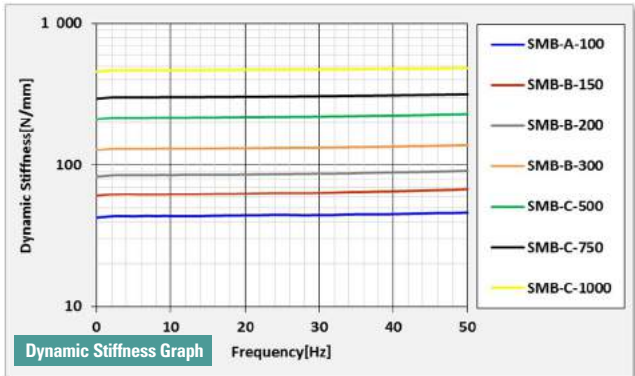
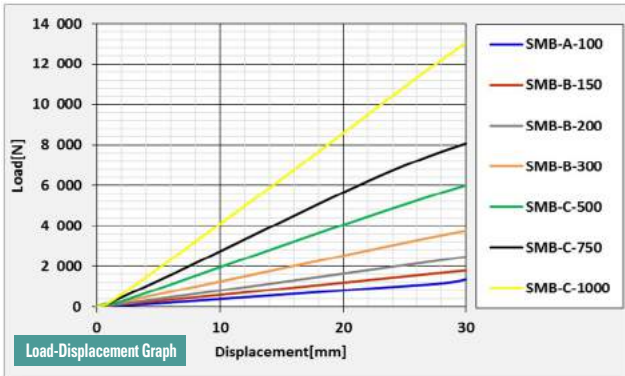

■ Explanation(Commonness)

1. Vibration Transmissibility(T_r)

Vibration Transmissibility is the amplitude ratio of Output to Input.

$$T_r = \frac{\text{Output Amplitude}}{\text{Input Amplitude}} = \sqrt{\left(\frac{1}{1-\eta^2}\right)^2}, \eta = \frac{\text{Disturbing Frequency of the equipment}}{\text{Natural Frequency of the Isolator (Damping}(c) = 0)}$$

2. Natural Frequency(F_n) of Vibration Isolation System

The mass and spring stiffness dictate a natural frequency of the system.

$$F_n = \frac{1}{2\pi} \sqrt{\frac{k}{m}}$$

3. Isolation Efficiency(E)

Isolation Efficiency in percent transmission is related to Vibration Transmissibility $E = 100(1 - T_r)$

ex) Disturbing Frequency of the equipment=100 Hz,

Natural Frequency of the isolator=10Hz

$$T_r = \sqrt{\left(\frac{1}{1-\eta^2}\right)^2} = \sqrt{\left(\frac{1}{1-\left(\frac{100}{10}\right)^2}\right)^2} = 0.101 \quad E = 100(1 - T_r) = 100(1-0.101)=99(\%)$$

■ Installation Features



SMB2 Spring Mount (Deflection : 50mm)

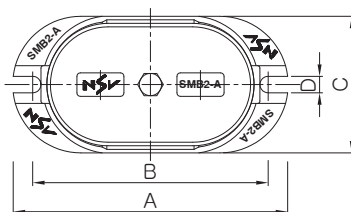
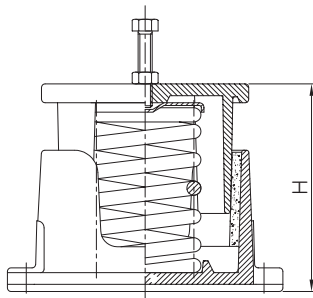
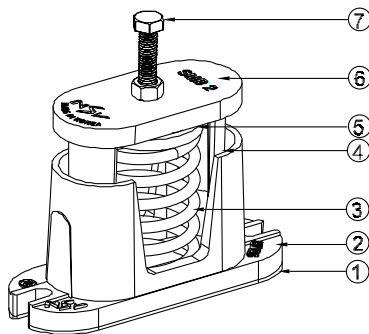

■ Features

As an enclosed spring mount, it has the same features and intended purpose as the SMB type, but is equipped with the spring having a static deflection of 50 mm. It is used when equipment like air conditioners and fans installed on a group floor of the building need to be kept quite when running.

■ Usage

- ◆ For high-efficient vibration isolation of pumps, refrigerators, compressors and power generators
- ◆ For high-efficient vibration isolation of ventilators
- ◆ For high-efficient vibration isolation of air conditioning units
- ◆ For equipment having large horizontal reaction

■ Specification

| No. | Name of Components | Material | Standard |
|-----|--------------------|----------|-----------|
| 1 | Non Skid Pad | CR | KS M 6617 |
| 2 | Lower Housing | GC | KS D 4301 |
| 3 | Coil Spring | SUP9 | KS B 2402 |
| | | HSW3 | KS B 2403 |
| 4 | Anti-Frictioner | SPONGE | - |
| 5 | Spring Cap | SS400 | KS D 3503 |
| 6 | Upper Housing | GC | KS D 4301 |
| 7 | Level Bolt | SS400 | KS B 1002 |

■ Dimension & Selection Guide

| Type | Capacity (kgf) | Spring Constant (kgf/mm) | Weight (kg) | Color | Dimension(mm) | | | | | |
|-----------|----------------|--------------------------|-------------|--------|---------------|-----|-----|----|-----|------------|
| | | | | | A | B | C | D | H | Level Blot |
| SMB2-50 | 50 | 1.0 | 8.30 | Red | 232 | 203 | 118 | 14 | 178 | M12 × 65 |
| SMB2-100 | 100 | 2.0 | 8.30 | Blue | | | | | | |
| SMB2-150 | 150 | 3.0 | 8.56 | Brown | | | | | | |
| SMB2-200 | 200 | 4.0 | 8.44 | White | | | | | | |
| SMB2-300 | 300 | 6.0 | 8.84 | Orange | | | | | | |
| SMB2-400 | 400 | 8.0 | 8.86 | Pink | | | | | | |
| SMB2-500 | 500 | 10.0 | 8.98 | Green | | | | | | |
| SMB2-600 | 600 | 12.0 | 8.98 | Blue | | | | | | |
| SMB2-750 | 750 | 15.0 | 8.74 | Black | | | | | | |
| SMB2-1000 | 1000 | 20.0 | 8.96 | Yellow | | | | | | |

(NOTE) The mentioned size and scale can be altered to improve the quality performance and capacity of the product without any notice.

SMB2 Spring Mount (Deflection : 50mm)

■ SMB2 Test Data

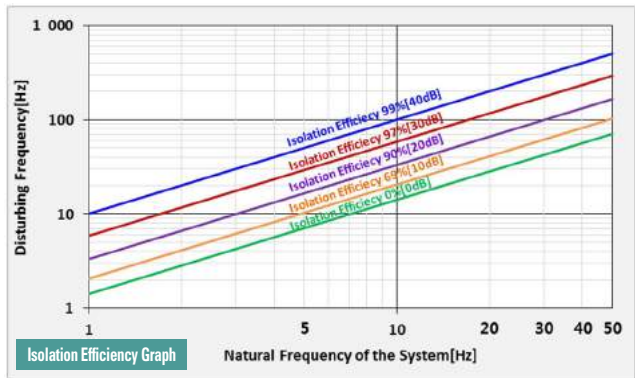
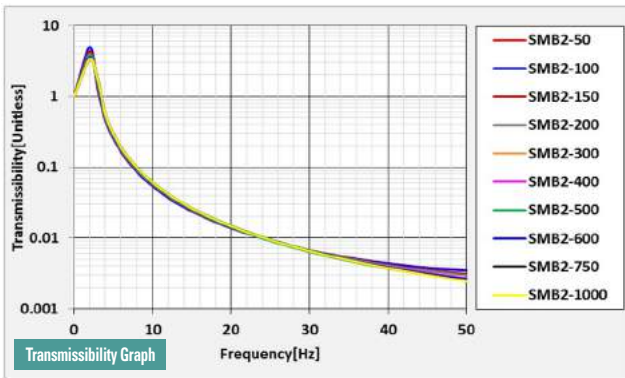
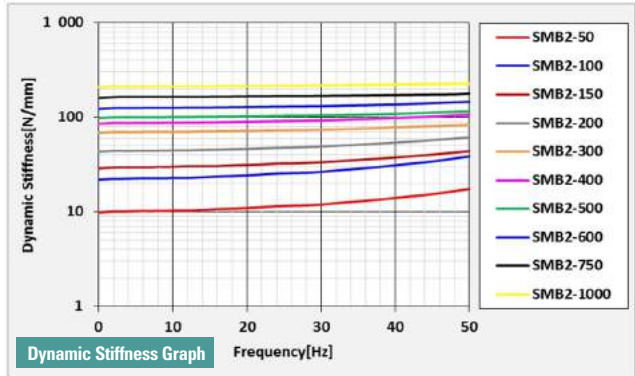
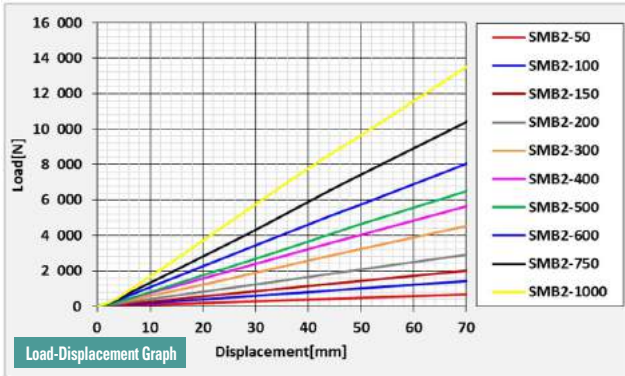

■ Installation Features

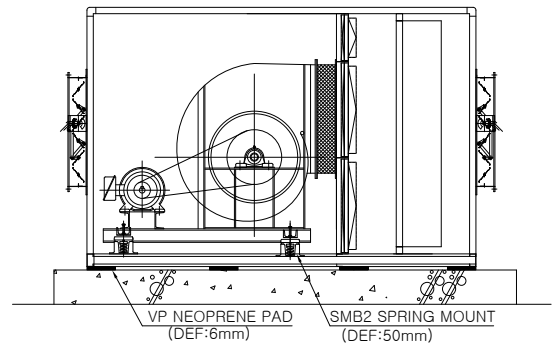
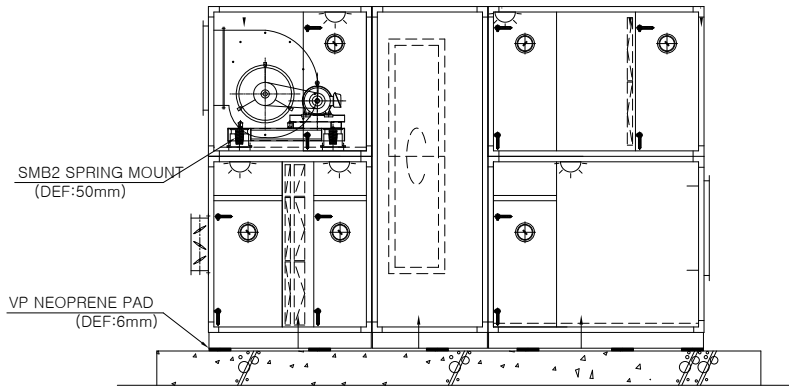

TOTAL HEAT EXCHANGER DETAIL

VENTILATION UNIT DETAIL



NSM/NSM2 Spring Mount (Deflection : 25mm, 50mm)

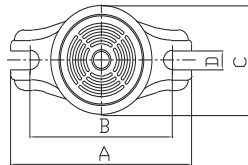
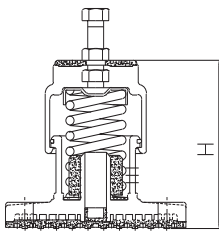
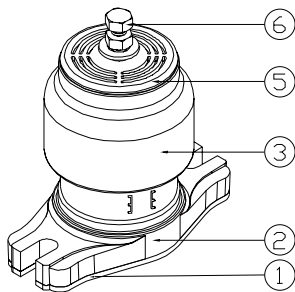

■ Features

It is a closed-spring mount with excellent anti-vibration effects. Because the spring is not exposed to the outside, it is corrosion-resistant and it has a gauge at the center to help check deflection. The top and bottom housings are made of POLYCARBONATE plastic, which is stable regardless of load and strength, and anti-friction inside the housing reduces structure-borne noise. Plus, the anti-vibration neoprene pad on the top and bottom contact surfaces prevents structure-borne noise from getting transferred to the base of the equipment when it is in contact with STEEL and concrete.

■ Usage

- ◆ For ventilators
- ◆ For air handling units
- ◆ For pumps and standing pipes
- ◆ For equipment with large horizontal reaction

■ Specification

| No. | Name of Components | Material | Standard |
|-----|--------------------|-----------|-----------|
| 1 | Lower Non Skin Pad | CR | KS M 6617 |
| 2 | Lower Housing | E-PLASTIC | |
| 3 | Upper Housing | E-PLASTIC | |
| 4 | Coil Spring | SUP9 | KS B 2402 |
| | | HSW3 | KS B 2403 |
| 5 | Upper Non Skid Pad | CR | KS M 6617 |
| 6 | Level Bolt | SS400 | KS B 1012 |

■ Dimension & Selection Guide

| Type | Capacity(kgf) | Spring Constant(kgf/mm) | Weight(kg) | Deflection(mm) | Dimension(mm) | | | | | |
|----------|---------------|-------------------------|------------|----------------|---------------|-----|-----|----|-----|------------|
| | | | | | A | B | C | D | H | Level Bolt |
| NSM-25 | 25 | 1.0 | 0.44 | 25 | 132 | 104 | 66 | 13 | 115 | M10X60 |
| NSM-50 | 50 | 2.0 | 0.46 | | | | | | | |
| NSM-75 | 75 | 3.0 | 0.50 | | | | | | | |
| NSM-100 | 100 | 4.0 | 0.54 | | | | | | | |
| NSM-150 | 150 | 6.0 | 1.16 | | | | | | | |
| NSM-200 | 200 | 8.0 | 1.22 | | 170 | 134 | 99 | 14 | 143 | M12X65 |
| NSM-300 | 300 | 12.0 | 1.36 | | | | | | | |
| NSM-400 | 400 | 16.0 | 1.38 | | | | | | | |
| NSM-500 | 500 | 20.0 | 2.08 | | | | | | | |
| NSM-600 | 600 | 24.0 | 2.14 | | | | | | | |
| NSM-750 | 750 | 30.0 | 2.22 | 50 | 223 | 183 | 137 | 14 | 180 | M12X65 |
| NSM2-50 | 50 | 1.0 | 2.44 | | | | | | | |
| NSM2-100 | 100 | 2.0 | 2.50 | | | | | | | |
| NSM2-150 | 150 | 3.0 | 2.46 | | | | | | | |
| NSM2-200 | 200 | 4.0 | 2.50 | | | | | | | |
| NSM2-300 | 300 | 6.0 | 2.70 | | | | | | | |
| NSM2-400 | 400 | 8.0 | 3.06 | | | | | | | |
| NSM2-500 | 500 | 10.0 | 2.76 | | | | | | | |
| NSM2-600 | 600 | 12.0 | 2.62 | | | | | | | |
| NSM2-750 | 750 | 15.0 | 2.92 | | | | | | | |

(NOTE) The mentioned size and scale can be altered to improve the quality performance and capacity of the product without any notice.

NSM/NSM2 Spring Mount (Deflection : 25mm, 50mm)

■ NSM Test Data

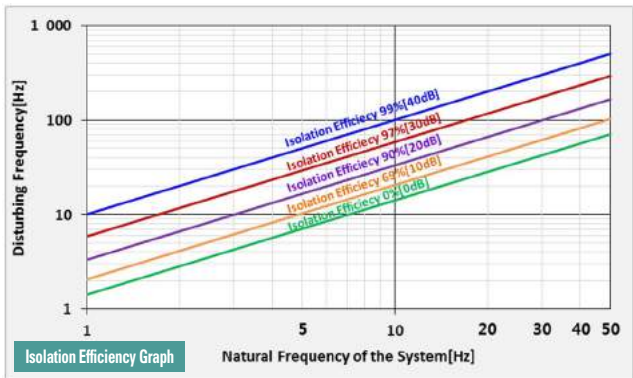
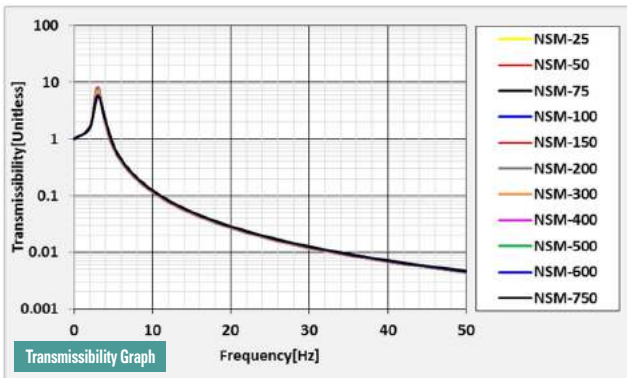
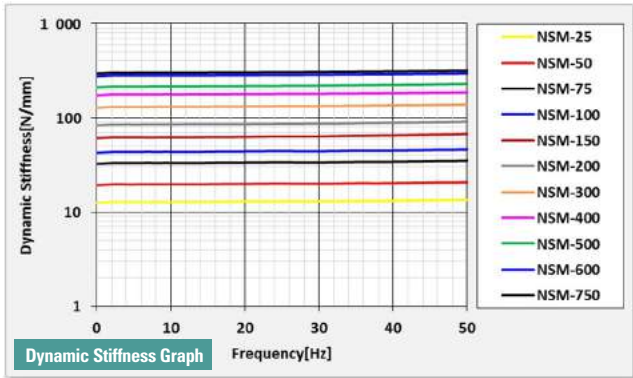
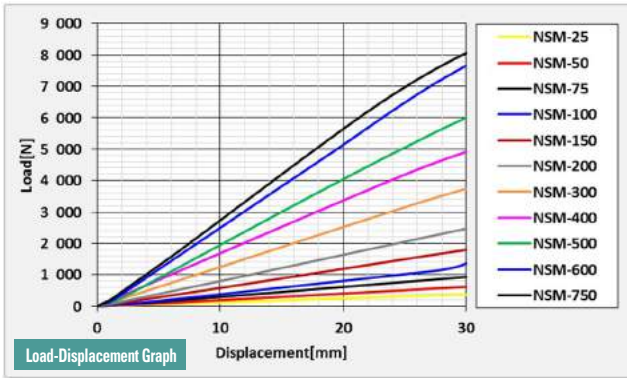

■ NSM2 Test Data

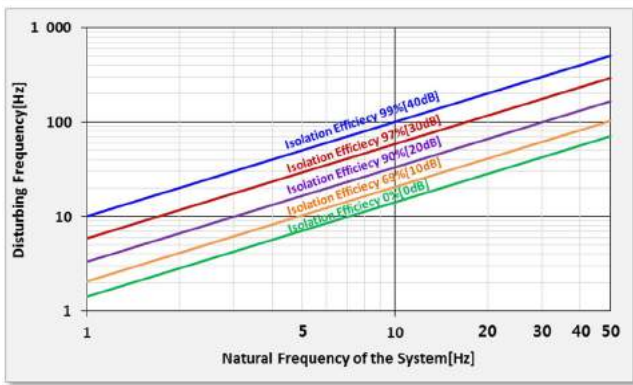
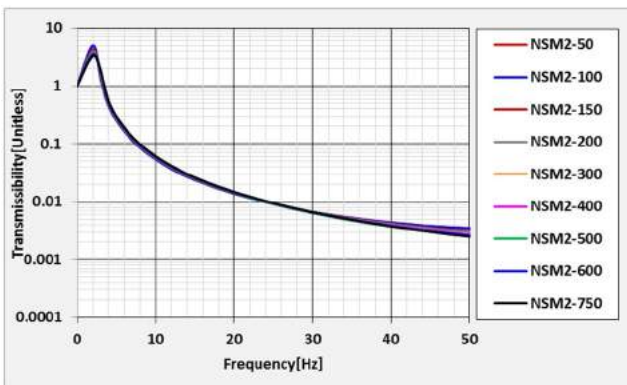
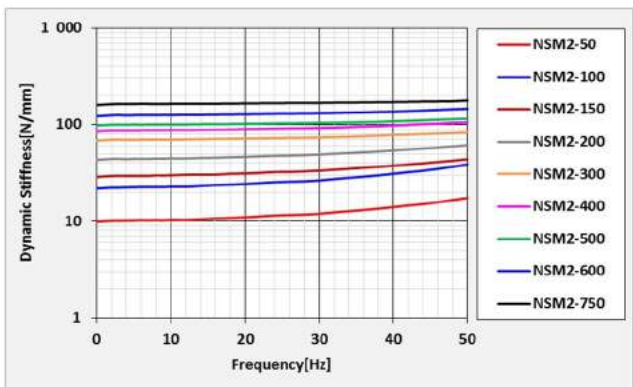
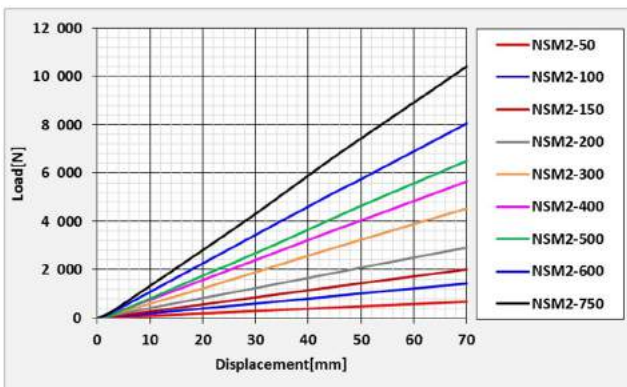

FSL Spring Mount (Deflection : 25mm)

■ Features

It is a free standing mount with a vertical movement limiting device. It is designed to restrict vertical deflection when there is any change in the weight of equipment and/or structure (for example, pouring water out of a cooling tower, refrigerator) to prevent damage and distortion of equipment and pipe. The upper housing (compression plate) has a restrain bolt and level bolt while CR-type acoustical non skid pad on the bottom to prevent transfer of high-frequency vibration.



FSL-1

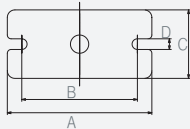
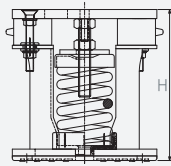
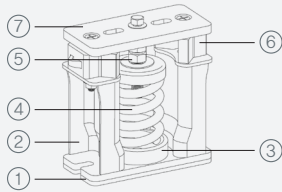

FSL-4

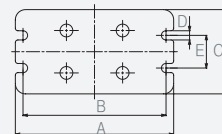
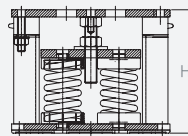
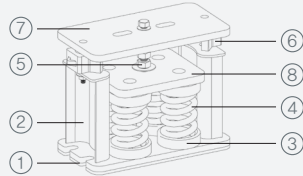

FSL-16

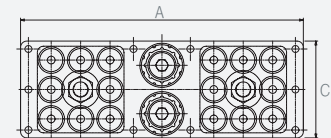
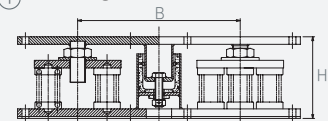
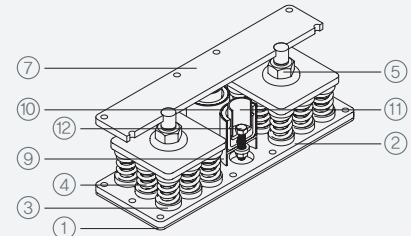

■ Usage

- ◆ For refrigerator of reciprocating and turbo types
- ◆ For cooling towers
- ◆ For other large pieces of equipment of which weight often changes

■ Specification

| No. | Name of Components | Material | Standard |
|-----|------------------------|----------|-----------|
| 1 | Non Skid Pad | CR | KS M 6617 |
| 2 | Lower Housing | SS400 | KS D 3503 |
| 3 | Spring Seat | CR | KS M 6617 |
| 4 | Coil Spring | SUP9 | KS B 2402 |
| | | HSW3 | KS B 2403 |
| 5 | Level Bolt&Nut | SS400 | KS B 1002 |
| 6 | Space Bar | Plastic | - |
| 7 | Upper Housing | SS400 | KS D 3503 |
| 8 | Middle Plate | SS400 | KS D 3503 |
| 9 | Lower Stopper | SS400 | KS D 3503 |
| 10 | Guide Rubber | CR | KS M 6617 |
| 11 | Upper Stopper | SS400 | KS D 3503 |
| 12 | Stopper Level Bolt&Nut | SS400 | KS B 1002 |

■ Installation Features



FSL Spring Mount (Deflection : 25mm)

■ Dimension & Selection Guide By Loads

| Type | Capacity (kgf) | Spring Constant (kgf/mm) | Weight (kg) | Color | Dimension(mm) | | | | | | |
|--------------|----------------|--------------------------|-------------|--------|---------------|-----|-----|----|-----|-----|------------|
| | | | | | A | B | C | D | E | H | Level Blot |
| FSL-1-300 | 300 | 12.0 | 3.90 | Orange | 190 | 153 | 90 | 14 | - | 199 | M16X80 |
| FSL-1-400 | 400 | 16.0 | 3.92 | Pink | | | | | | | |
| FSL-1-500 | 500 | 20.0 | 4.46 | Green | | | | | | | |
| FSL-1-600 | 600 | 24.0 | 4.54 | Blue | | | | | | | |
| FSL-1-750 | 750 | 30.0 | 4.60 | Black | | | | | | | |
| FSL-1-1000 | 1,000 | 40.0 | 4.78 | Yellow | | | | | | | |
| FSL-1-1200 | 1,200 | 48.0 | 4.66 | Red | 302 | 262 | 90 | 14 | - | 199 | M20X90 |
| FSL-2-1200 | 1,200 | 48.0 | 8.78 | Blue | | | | | | | |
| FSL-2-1500 | 1,500 | 60.0 | 8.94 | Black | | | | | | | |
| FSL-2-2000 | 2,000 | 80.0 | 9.32 | Yellow | 310 | 280 | 165 | 18 | 64 | 242 | M24X110 |
| FSL-2-2400 | 2,400 | 96.0 | 9.06 | Red | | | | | | | |
| FSL-4-3000 | 3,000 | 120.0 | 24.4 | Black | | | | | | | |
| FSL-4-4000 | 4,000 | 160.0 | 25.1 | Yellow | 570 | 313 | 215 | 15 | 175 | 217 | M36X120 |
| FSL-4-4800 | 4,800 | 192.0 | 24.6 | Red | | | | | | | |
| FSL-8-8000 | 8,000 | 320.0 | 46.3 | Yellow | | | | | | | |
| FSL-8-9600 | 9,600 | 384.0 | 47.9 | Red | 894 | 514 | 306 | 22 | 256 | 258 | M48X140 |
| FSL-8-12000 | 12,000 | 480.0 | 49.5 | Black | | | | | | | |
| FSL-16-16000 | 16,000 | 640.0 | 169.8 | Yellow | | | | | | | |
| FSL-16-19200 | 19,200 | 768.0 | 173.0 | Red | | | | | | | |
| FSL-16-24000 | 24,000 | 960.0 | 176.2 | Black | | | | | | | |

(NOTE) The specification and data are subject to change without prior to for improvement of product performance and quality.

■ FSL Test Data

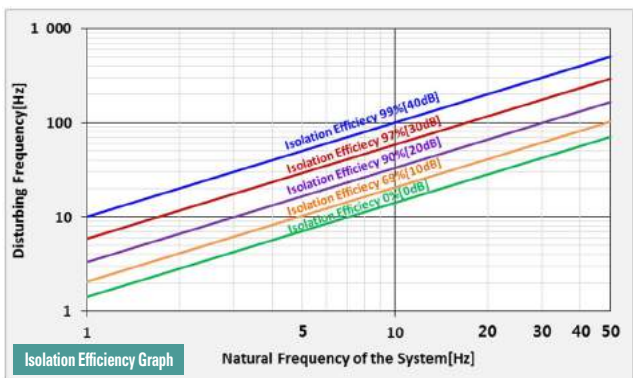
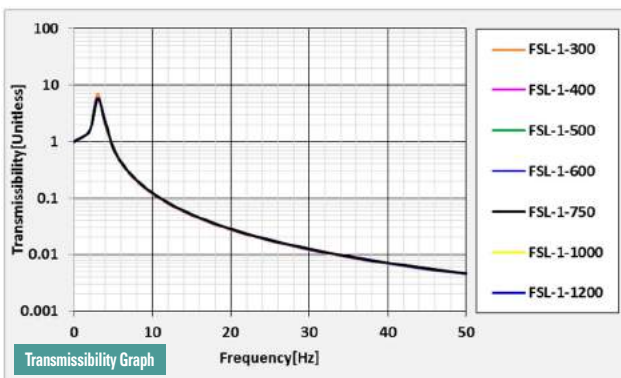
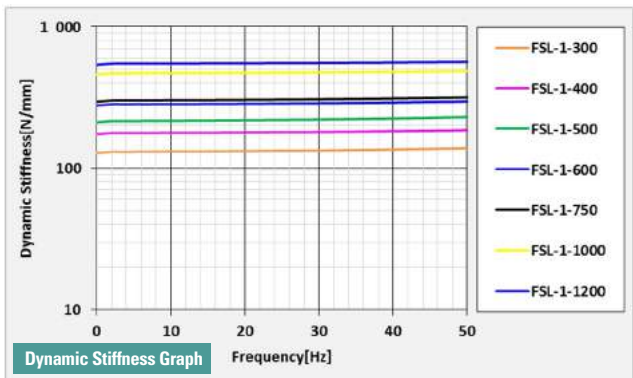
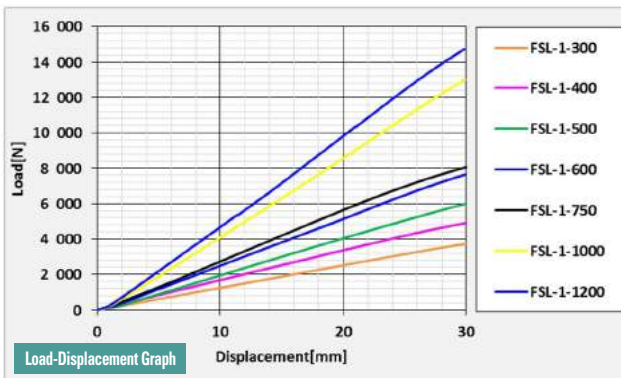

FSL2 Spring Mount (Deflection : 50mm)

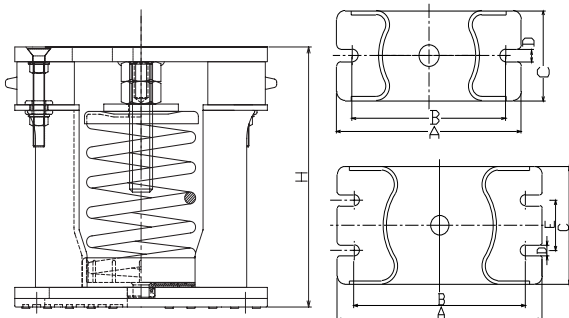
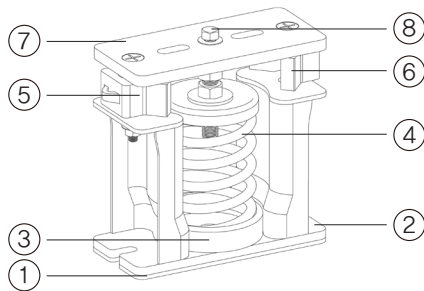

■ Features

As a type of FSL series, it uses SMA2 type (static deflection of 50mm) and prevents damage and distortion of the equipment and pipe. The upper housing (compression plate) has a restraint bolt and level bolt, while the CR-type acoustical non skid pad on the bottom is to prevent the transfer of high-frequency vibration).

■ Usage

- ◆ For refrigerator of reciprocating and turbo types
- ◆ For cooling towers
- ◆ For other large pieces of equipment of which weight often changes

■ Specification

| No. | Name of Components | Material | Standard |
|-----|--------------------|----------|-----------|
| 1 | Non Skid Pad | CR | KS M 6617 |
| 2 | Lower Housing | SS400 | KS D 3503 |
| 3 | Spring Seat | CR | KS M 6617 |
| 4 | Coil Spring | SUP9 | KS B 2402 |
| | | HSW3 | KS B 2403 |
| 5 | Restraint Bolt | SS400 | KS B 1002 |
| 6 | Space Bar | Plastic | - |
| 7 | Upper Housing | SS400 | KS D 3503 |
| 8 | Level Bolt | SS400 | KS B 1002 |

■ Dimension & Selection Guide By Loads

| Type | Capacity (kgf) | Spring Constant (kgf/mm) | Weight (kg) | Color | Dimension(mm) | | | | | | |
|-----------|----------------|--------------------------|-------------|--------|---------------|-----|-----|----|----|-----|------------|
| | | | | | A | B | C | D | E | H | Level Blot |
| FSL2-200 | 200 | 4.0 | 10.6 | White | 220 | 183 | 100 | 14 | - | 212 | M20X90 |
| FSL2-300 | 300 | 6.0 | 10.7 | Orange | | | | | | | |
| FSL2-400 | 400 | 8.0 | 10.9 | Pink | | | | | | | |
| FSL2-500 | 500 | 10.0 | 18.0 | Green | | | | | | | |
| FSL2-600 | 600 | 12.0 | 18.5 | Blue | | | | | | | |
| FSL2-750 | 750 | 15.0 | 19.0 | Black | 280 | 234 | 150 | 14 | 64 | 292 | M20X110 |
| FSL2-1000 | 1,000 | 20.0 | 19.5 | Yellow | | | | | | | |
| FSL2-1200 | 1,200 | 24.0 | 20.0 | Red | | | | | | | |
| FSL2-1500 | 1,500 | 30.0 | 32.5 | Black | | | | | | | |
| FSL2-1800 | 1,800 | 36.0 | 33.0 | Blue | | | | | | | |
| FSL2-2000 | 2,000 | 40.0 | 33.5 | Yellow | 330 | 276 | 180 | 16 | 64 | 338 | M24X110 |
| FSL2-2500 | 2,500 | 50.0 | 34.0 | Brown | | | | | | | |
| FSL2-2400 | 2,400 | 48.0 | 38.0 | Brown | | | | | | | |
| FSL2-3000 | 3,000 | 60.0 | 39.0 | White | | | | | | | |
| FSL2-3200 | 3,200 | 64.0 | 39.5 | White | | | | | | | |
| FSL2-3500 | 3,500 | 70.0 | 40.0 | Black | | | | | | | |
| FSL2-4000 | 4,000 | 80.0 | 42.0 | Orange | | | | | | | |

(NOTE) The specification and data are subject to change without prior to for improvement of product performance and quality.

FSL2 Spring Mount (Deflection : 50mm)

■ FSL2 Test Data

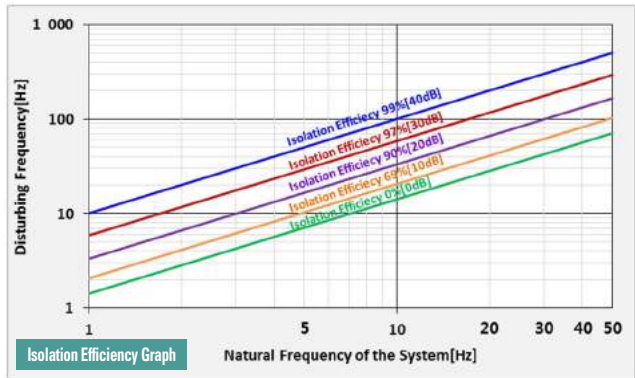
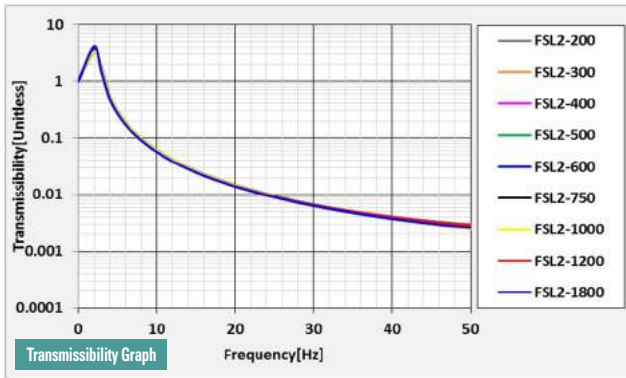
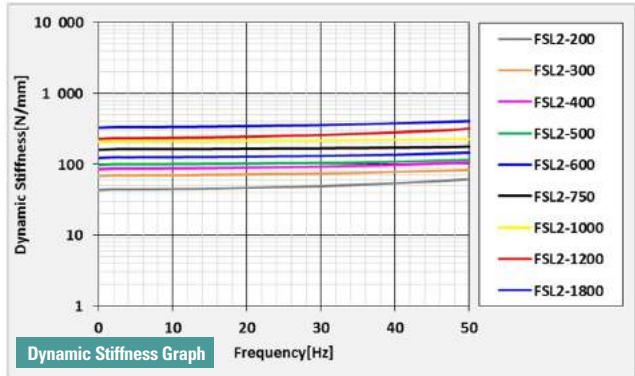
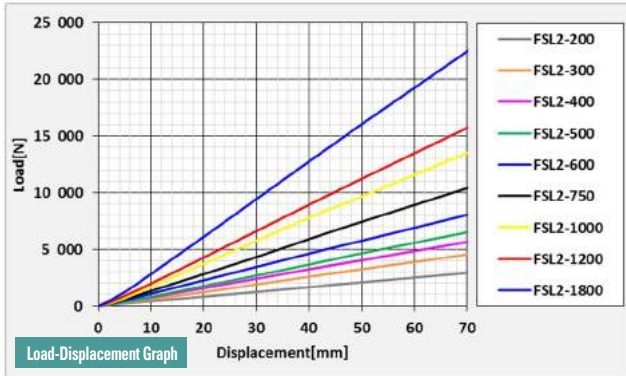

■ Installation Features



SMA3 Spring Mount (Deflection : 75mm)

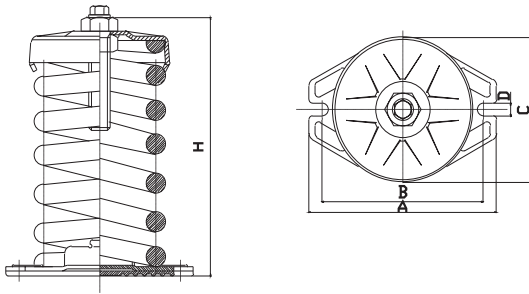
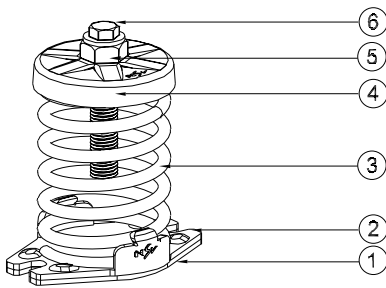

■ Features

It has same features and intended purpose as SMA2 type, but it uses the spring having a static deflection of 75 mm, which makes it better suited for more delicate vibration control than SMA2 type. The average length of slab is 6~9 mm and it is applied to equipment with the natural frequency less than 8.3Hz (500RPM) installed on rooftop. In this case, it must have the natural frequency of less than 2Hz and the static deflection of at least 60 mm.

■ Usage

- ◆ For high-efficient vibration control of standing pipes
- ◆ For high-efficient vibration control of ventilator (ground level)
- ◆ For high-efficient vibration control of air conditioning unit (ground level)
- ◆ For high-efficient vibration control of equipment that needs to be kept quiet

■ Specification

| No. | Name of Components | Material | Standard |
|-----|--------------------|----------|-----------|
| 1 | Non Skid Pad | CR | KS M 6617 |
| 2 | Lower Housing | GC | KS D 4301 |
| 3 | Coil Spring | SUP9 | KS B 2402 |
| | | HSW3 | KS B 2403 |
| 4 | Upper Spring Cap | SS400 | KS D 3503 |
| 5 | Level Bolt | SS400 | KS B 1002 |
| 6 | Cap Screw | SS400 | KS B 1002 |

■ Dimension & Selection Guide

| Type | Capacity (kgf) | Spring Constant (kgf/mm) | Weight (kg) | Color | Dimension(mm) | | | | | | |
|-------------|----------------|--------------------------|-------------|--------|---------------|-----|-----|----|-----|------------|-----------|
| | | | | | A | B | C | D | H | Level Blot | Cap Screw |
| SMA3-A-200 | 200 | 2.7 | 8.1 | White | 190 | 170 | 138 | 14 | 230 | M20 × 110 | M12 × 25 |
| SMA3-A-300 | 300 | 4.0 | 8.1 | Orange | | | | | | | |
| SMA3-B-400 | 400 | 5.3 | 8.2 | Pink | | | | | | | |
| SMA3-B-500 | 500 | 6.7 | 9.5 | Green | 190 | 170 | 138 | 14 | 253 | M20 × 110 | M12 × 25 |
| SMA3-B-600 | 600 | 8.0 | 9.7 | Blue | | | | | | | |
| SMA3-B-750 | 750 | 10.0 | 9.7 | Black | | | | | | | |
| SMA3-B-1000 | 1000 | 13.3 | 9.8 | Yellow | | | | | | | |
| SMA3-C-1200 | 1200 | 16.0 | 14.8 | Red | | | | | | | |
| SMA3-C-1500 | 1500 | 20.0 | 14.9 | Black | 214 | 184 | 162 | 14 | 289 | M24 × 140 | M12 × 40 |
| SMA3-C-1800 | 1800 | 24.0 | 15.2 | Blue | | | | | | | |
| SMA3-C-2000 | 2000 | 32.0 | 15.5 | Yellow | | | | | | | |
| SMA3-C-2500 | 2500 | 33.3 | 15.6 | Brown | | | | | | | |
| SMA3-D-3000 | 3000 | 40.0 | 24.1 | White | 260 | 234 | 204 | 16 | 329 | M24 × 140 | M12 × 40 |
| SMA3-D-3500 | 3500 | 46.6 | 25.2 | Black | | | | | | | |
| SMA3-D-4000 | 4000 | 53.3 | 26.8 | Orange | | | | | | | |

(NOTE) The mentioned size and scale can be altered to improve the quality performance and capacity of the product without any notice.

FSL3 Spring Mount (Deflection : 75mm)

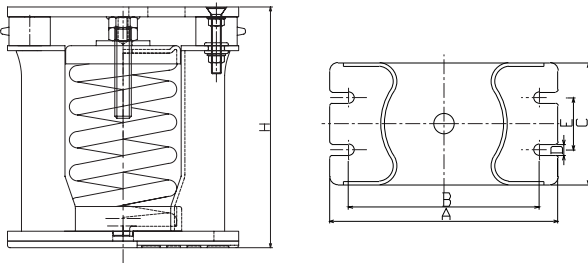
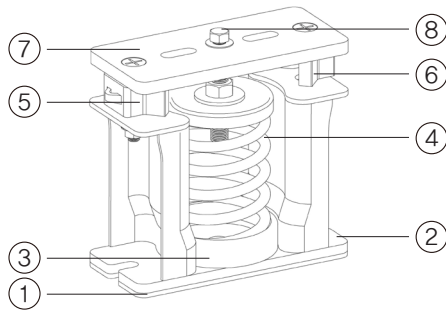

■ Features

Though it has same features as FSL2 type, it uses a spring with the static deflection of 75mm and therefore, it is used when more delicate vibration control is required. For example, it is mounted on equipment installed on a rooftop having the average slab length of 6~9 m and natural frequency less than 8.3 Hz (500RPM). In such a case, the natural frequency of the vibration control system needs to have the natural frequency of less than 2 Hz and at least 60 mm static deflection. FSA3 series spring is used in this model.

■ Usage

- ◆ High-efficiency vibration control for refrigerators of reciprocating and turbo types
- ◆ High-efficiency vibration control for cooling towers
- ◆ High-efficiency vibration control for other large pieces of equipment of which undergoes frequent weight changes (such as semiconductor production facilities)

■ Specification

| No. | Name of Components | Material | Standard |
|-----|--------------------|----------|-----------|
| 1 | Non Skid Pad | CR | KS M 6617 |
| 2 | Lower Housing | SS400 | KS D 3503 |
| 3 | Spring Seat | CR | KS M 6617 |
| 4 | Coil Spring | SUP9 | KS B 2402 |
| | | HSW3 | KS B 2403 |
| 5 | Restraint Bolt | SS400 | KS B 1002 |
| 6 | Space Bar | Plastic | - |
| 7 | Upper Housing | SS400 | KS D 3503 |
| 8 | Level Bolt | SS400 | KS B 1002 |

■ Dimension & Selection Guide By Loads

| Type | Capacity (kgf) | Spring Constant (kgf/mm) | Weight (kg) | Color | Dimension(mm) | | | | | | |
|-----------|----------------|--------------------------|-------------|--------|---------------|-----|-----|----|----|-----|------------|
| | | | | | A | B | C | D | E | H | Level Blot |
| FSL3-200 | 200 | 2.7 | 10.6 | White | 280 | 234 | 150 | 14 | 64 | 292 | M20X140 |
| FSL3-300 | 300 | 4.0 | 10.7 | Orange | | | | | | | |
| FSL3-400 | 400 | 5.3 | 10.9 | Pink | | | | | | | |
| FSL3-600 | 600 | 8.0 | 18.5 | Blue | | | | | | | |
| FSL3-750 | 750 | 10.0 | 19.0 | Black | | | | | | | |
| FSL3-1000 | 1000 | 13.3 | 19.5 | Yellow | 330 | 276 | 180 | 16 | 64 | 338 | M24X110 |
| FSL3-1200 | 1200 | 16.0 | 32.5 | Red | | | | | | | |
| FSL3-1500 | 1500 | 20.0 | 33.2 | Black | | | | | | | |
| FSL3-1800 | 1800 | 24.0 | 36.0 | Blue | | | | | | | |
| FSL3-2000 | 2000 | 26.6 | 40.0 | Yellow | | | | | | | |
| FSL3-2500 | 2500 | 33.3 | 45.0 | Brown | 350 | 316 | 160 | 18 | 64 | 397 | M24X190 |
| FSL3-3000 | 3000 | 40.0 | 52.0 | White | | | | | | | |
| FSL3-3500 | 3500 | 46.6 | 59.0 | Black | | | | | | | |
| FSL3-4000 | 4000 | 46.6 | 59.0 | Black | | | | | | | |

(NOTE) The specification and data are subject to change without prior to for improvement of product performance and quality.

SH Spring Hanger (Deflection : 25mm)

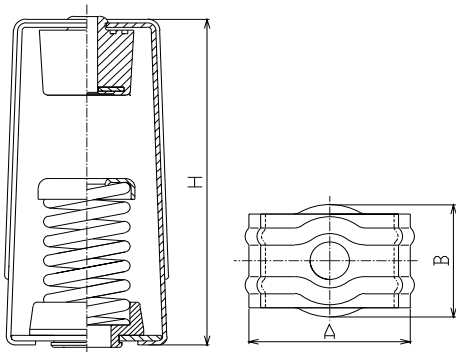
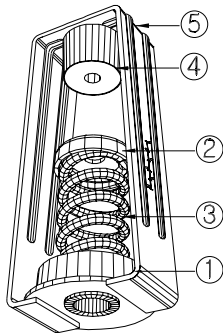

■ Features

The SH type anti-vibration spring hanger ensures that vibration generated from the equipment and/or stress by thermal expansion in the pipe and duct while the equipment is running are not transferred to the structure through pipe and duct. The housing needs to be strong enough to stand the weight of the equipment without causing resonance from its own vibration. With the coil spring having a static deflection of 25 mm, the product can maintain the system's natural frequency down to 3~5 Hz and the CR type housing fixture is mounted on top of the housing to prevent high frequency that is passed through pipe and duct from getting into the structure on top of the hanger. Plus, the CR type spring sheet is attached at the bottom to block the high frequency resulting from the vibration that the spring generates itself.

■ Usage

- ◆ For high-efficient vibration control of axial, in-line fan, machine room, pipes in air-conditioning room and ducts
- ◆ For high-efficient vibration control of suspended ceiling desk system in, for example, studios and acoustical laboratories

■ Specification

| No. | Name of Components | Material | Standard |
|-----|--------------------|----------|-----------|
| 1 | Spring Seat | CR | KS M 6617 |
| 2 | Spring Cap | SS400 | KS D 3503 |
| 3 | Coil Spring | SUP9 | KS B 2402 |
| | | HSW3 | KS B 2403 |
| 4 | Housing Fixture | CR | KS M 6617 |
| 5 | Hanger Housing | SS400 | KS D 3503 |

(NOTE) Housing Fixture A/B Type Hardness : 60° / Housing Fixture C Type Hardness : 70°

■ Dimension & Selection Guide

| Type | Capacity (kgf) | Spring Constant (kgf/mm) | Weight (kg) | Color | Dimension(mm) | | | |
|-----------|----------------|--------------------------|-------------|--------|---------------|-----|-----|------------|
| | | | | | A | B | H | Level Blot |
| SH-A-10 | 10 | 0.4 | 0.70 | Pink | 82 | 60 | 172 | M10 |
| SH-A-25 | 25 | 1.0 | 0.74 | Yellow | | | | |
| SH-A-50 | 50 | 2.0 | 0.76 | Red | | | | |
| SH-A-75 | 75 | 3.0 | 0.80 | Black | | | | |
| SH-A-100 | 100 | 4.0 | 0.84 | Blue | | | | |
| SH-B-150 | 150 | 6.0 | 1.80 | Brown | 103 | 79 | 215 | M12 |
| SH-B-200 | 200 | 8.0 | 1.84 | White | | | | |
| SH-B-300 | 300 | 12.0 | 1.98 | Orange | | | | |
| SH-B-400 | 400 | 16.0 | 2.02 | Pink | | | | |
| SH-C-500 | 500 | 20.0 | 3.34 | Green | 118 | 100 | 243 | M16 |
| SH-C-600 | 600 | 24.0 | 3.40 | Blue | | | | |
| SH-C-750 | 750 | 30.0 | 3.50 | Black | | | | |
| SH-C-1000 | 1000 | 40.0 | 3.68 | Yellow | | | | |

(NOTE) The mentioned size and scale can be altered to improve the quality performance and capacity of the product without any notice.

SH Spring Hanger (Deflection : 25mm)

SH Test Data

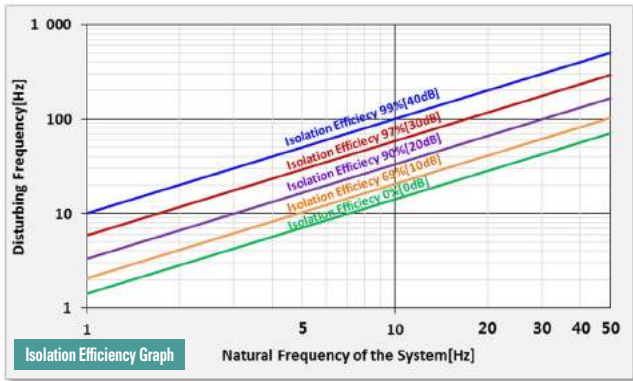
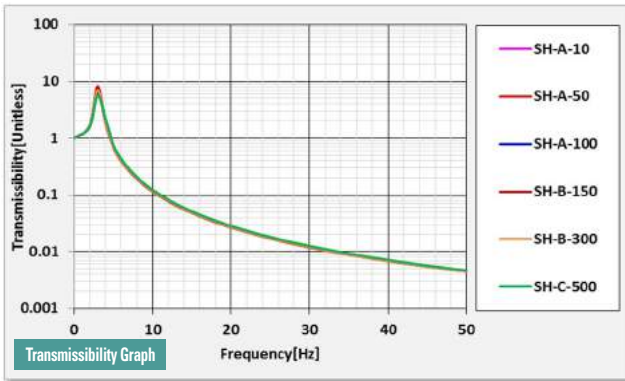
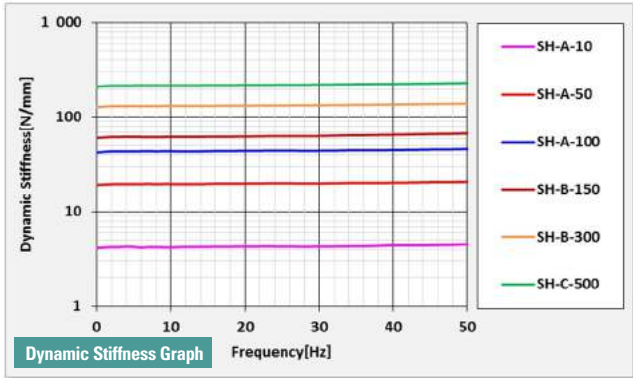
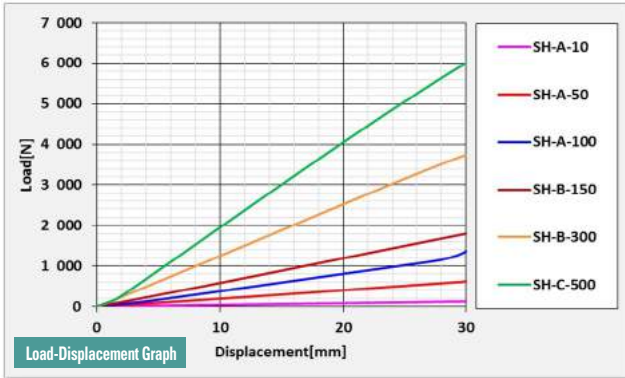

Explanation(Commonness)

1. Vibration Transmissibility(T_r)

Vibration Transmissibility is the amplitude ratio of Output to Input.

$$T_r = \frac{\text{Output Amplitude}}{\text{Input Amplitude}} = \sqrt{\left(\frac{1}{1-\eta^2}\right)^2}, \eta = \frac{\text{Disturbing Frequency of the equipment}}{\text{Natural Frequency of the Isolator (Damping}(c) = 0)}$$

2. Natural Frequency(F_n) of Vibration Isolation System

The mass and spring stiffness dictate a natural frequency of the system.

$$F_n = \frac{1}{2\pi} \sqrt{\frac{k}{m}}$$

3. Isolation Efficiency(E)

Isolation Efficiency in percent transmission is related to Vibration Transmissibility $E = 100(1 - T_r)$

ex) Disturbing Frequency of the equipment=100 Hz,

Natural Frequency of the isolator=10Hz

$$T_r = \sqrt{\left(\frac{1}{1-\eta^2}\right)^2} = \sqrt{\left(\frac{1}{1-\left(\frac{100}{10}\right)^2}\right)^2} = 0.101 \quad E = 100(1 - T_r) = 100(1-0.101)=99(\%)$$

Installation Features



VH20 Spring Hanger (Deflection : 25mm)

※ The model name of VH product has changed to VH20

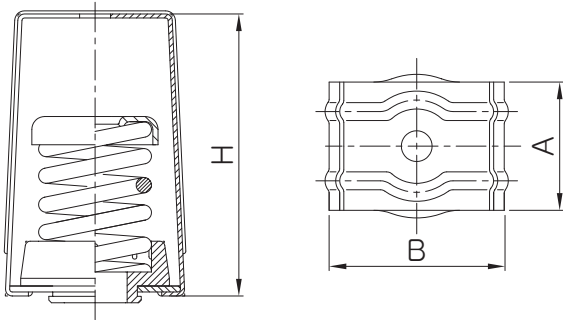
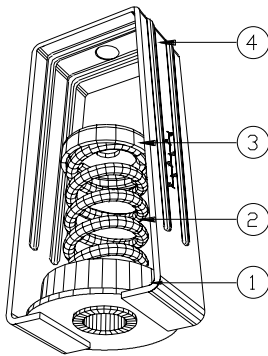

■ Features

The VH20 type anti-vibration spring hanger prevents the transfer of vibration generated from equipment and/or stress resulted from thermal expansion in pipes and ducts during operation. Its housing needs to be strong enough to stand the weight of the equipment and avoid resonance due to the vibration it generates. With the coil spring having a static deflection of 25 mm, it can maintain the system's natural frequency down to 3-5 Hz and the CR type housing fixture is mounted on the housing to avoid the transfer of high frequency from pipes and ducts into the structure on top of the hanger. Plus, the CR type spring sheet is attached on the bottom to block high frequency resulting from the vibration that the spring itself generates.

■ Usage

- ◆ For high-efficient vibration control of axial, in-line fan, machine rooms, pipes in air-conditioning rooms and ducts
- ◆ For high-efficient vibration control of suspended ceiling desk system in, for example, studios and acoustical laboratories

■ Specification

| No. | Name of Components | Material | Standard |
|-----|--------------------|----------|-----------|
| 1 | Spring Seat | CR | KS M 6617 |
| 2 | Coil Spring | SUP9 | KS B 2402 |
| | | HSW3 | KS B 2403 |
| 3 | Spring Cap | SS400 | KS D 4301 |
| 4 | Hanger Housing | SS400 | KS D 3503 |

■ Dimension & Selection Guide

| Type | Capacity (kgf) | Spring Constant (kgf/mm) | Weight (kg) | Color | Dimension(mm) | | | |
|----------|----------------|--------------------------|-------------|--------|---------------|----|-----|------------|
| | | | | | A | B | H | Level Blot |
| VH20-10 | 10 | 0.4 | 3.38 | Pink | 70 | 60 | 135 | M10 |
| VH20-25 | 25 | 1.0 | 0.42 | Yellow | | | | |
| VH20-50 | 50 | 2.0 | 0.44 | Red | | | | |
| VH20-75 | 75 | 3.0 | 0.48 | Black | | | | |
| VH20-100 | 100 | 4.0 | 0.52 | Blue | | | | |
| VH20-150 | 150 | 6.0 | 0.52 | Brown | | | | |
| VH20-150 | 150 | 6.0 | 1.40 | Brown | 96 | 80 | 170 | M12 |
| VH20-200 | 200 | 8.0 | 1.44 | White | | | | |
| VH20-300 | 300 | 12.0 | 1.60 | Orange | | | | |
| VH20-400 | 400 | 16.0 | 1.65 | Pink | | | | |

(NOTE) The mentioned size and scale can be altered to improve the quality performance and capacity of the product without any notice.

VH61 Spring Hanger (Deflection : 25mm)

※ The model name of VSH product has changed to VH61

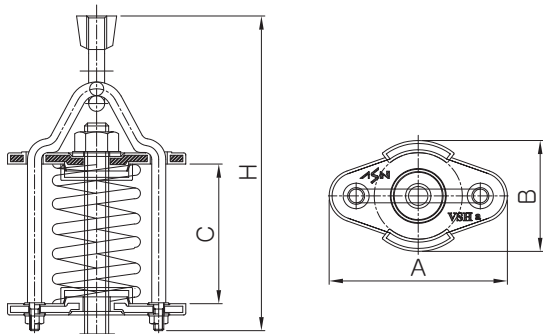
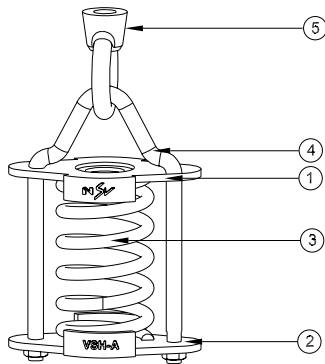

■ Features

The VH61 type anti-vibration spring hanger prevents the transfer of vibration generated from equipment and/or stress resulted from thermal expansion in the pipes and ducts during operation. Unlike the SH type, it uses a V-bolt instead of the housing, which allows it to withstand a dynamic load. Using the coil spring with a static deflection of 25 mm, it maintains the system's natural frequency to 3~5 Hz and using the CR type guide Rubber attached on the top plate, it prevents the high frequency transferred through pipes and ducts from passing into the structure on top of the hanger. In addition, it can be assembled with 60% of the available load using the pre-setting nut to prevent the equipment from moving around by the distortion of the spring, and because the spring is coupled with V-bolt, the spring does not fall apart when moving the mount.

(Option) The hanger rod can be installed using the hole on the top/bottom plates to suspend the equipment.

■ Usage

For high-efficient vibration control of axial, in-line fan, machine rooms, pipes in air-conditioning rooms and ducts

■ Specification

| No. | Name of Components | Material | Standard |
|-----|-------------------------------|----------|-----------|
| 1 | Upper Plate(neoprene coating) | SS400 | KS D 3503 |
| 2 | Lower Plate(neoprene coating) | SS400 | KS D 3503 |
| 3 | Coil Spring | SUP9 | KS B 2402 |
| | | HSW3 | KS B 2403 |
| 4 | Hanging V-Blot | SS400 | - |
| 5 | I-Nut | SS400 | - |

■ Dimension & Selection Guide

| Type | Capacity (kgf) | Spring Constant (kgf/mm) | Weight (kg) | Color | Dimension(mm) | | | | | |
|----------|----------------|--------------------------|-------------|--------|---------------|----|-----|-----|-------|--------------|
| | | | | | A | B | C | H | I-Nut | Hanging Bolt |
| VH61-10 | 10 | 0.4 | 0.36 | Pink | 89 | 57 | 84 | 160 | 3/8" | M10 |
| VH61-25 | 25 | 1.0 | 0.40 | Yellow | | | | | | |
| VH61-50 | 50 | 2.0 | 0.44 | Red | | | | | | |
| VH61-75 | 75 | 3.0 | 0.46 | Black | | | | | | |
| VH61-100 | 100 | 4.0 | 0.50 | Blue | | | | | | |
| VH61-150 | 150 | 6.0 | 0.91 | Brown | 108 | 74 | 116 | 214 | 1/2" | M12 |
| VH61-150 | 150 | 6.0 | 1.14 | Brown | | | | | | |
| VH61-200 | 200 | 8.0 | 1.18 | White | | | | | | |
| VH61-300 | 300 | 12.0 | 1.32 | Orange | | | | | | |
| VH61-400 | 400 | 16.0 | 1.58 | Pink | | | | | | |

(NOTE) The mentioned size and scale can be altered to improve the quality performance and capacity of the product without any notice.

VH62 Spring Hanger (Deflection : 50mm)

※ The model name of VSH2 product has changed to VH62

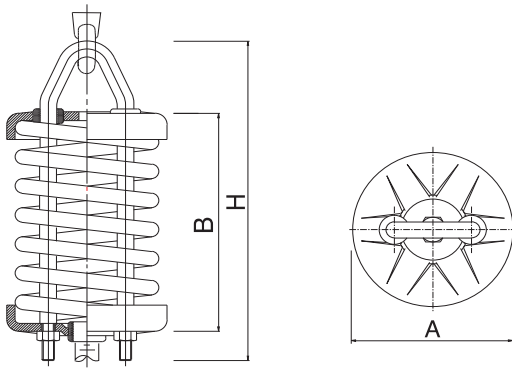
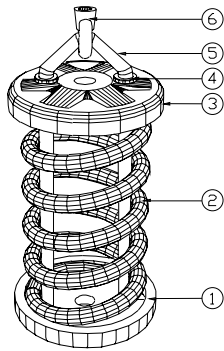

■ Features

Though it has the same features and intended purpose as VH62 type, it has a static deflection of 50 mm, which makes it best suitable for pipes and ducts in semiconductor plants. It uses a hanger-rod bolt on the upper-spring cap to fix onto equipment and the upper I-nut when installed on a suspended ceiling structure.

(Option) The hanger rod can be installed using the hole on top/bottom plates to suspend the equipment.

■ Usage

- ◆ For high-efficient vibration control of axial, in-line fan, machine rooms, pipes in air-conditioning rooms and ducts
- ◆ For high-efficient vibration control of suspended ceiling deck system in, for example, acoustical laboratories and studios
- ◆ For pipes and ducts installed in semiconductor plants

■ Specification

| No. | Name of Components | Material | Standard |
|-----|--------------------|----------|-----------|
| 1 | Lower Plate | SS400 | KS D 3503 |
| 2 | Coil Spring | SUP9 | KS B 2402 |
| | | HSW3 | KS B 2403 |
| 3 | Upper Spring Cap | SS400 | KS D 3503 |
| 4 | Guide Rubber | CR | KS M 6617 |
| 5 | Hanging V-Bolt | SS400 | - |
| 6 | I-Nut | SS400 | - |

■ Dimension & Selection Guide

| Type | Capacity (kgf) | Spring Constant (kgf/mm) | Weight (kg) | Color | Dimension(mm) | | | | |
|-----------|----------------|--------------------------|-------------|--------|---------------|-----|-----|-------|--------------|
| | | | | | A | B | H | I-Nut | Hanging Bolt |
| VH62-10 | 10 | 0.2 | 1.66 | Pink | 106 | 150 | 227 | 1/2" | M12 |
| VH62-25 | 25 | 0.5 | 1.80 | Yellow | | | | | |
| VH62-50 | 50 | 1.0 | 2.10 | Red | | | | | |
| VH62-75 | 75 | 1.5 | 2.10 | Black | | | | | |
| VH62-100 | 100 | 2.0 | 2.16 | Blue | | | | | |
| VH62-150 | 150 | 3.0 | 2.12 | Brown | | | | | |
| VH62-200 | 200 | 4.0 | 2.16 | White | | | | | |
| VH62-300 | 300 | 6.0 | 2.30 | Orange | | | | | |
| VH62-400 | 400 | 8.0 | 2.70 | Pink | | | | | |
| VH62-500 | 500 | 10.0 | 2.42 | Green | | | | | |
| VH62-600 | 600 | 12.0 | 2.28 | Blue | | | | | |
| VH62-750 | 750 | 15.0 | 2.58 | Black | | | | | |
| VH62-1000 | 1000 | 20.0 | 2.76 | Yellow | | | | | |

(NOTE) The mentioned size and scale can be altered to improve the quality performance and capacity of the product without any notice.

VH20/VH61/VH62 Spring Hanger

■ VH20 Test Data

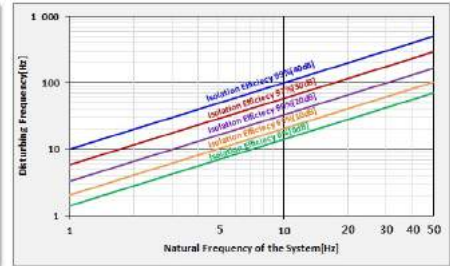
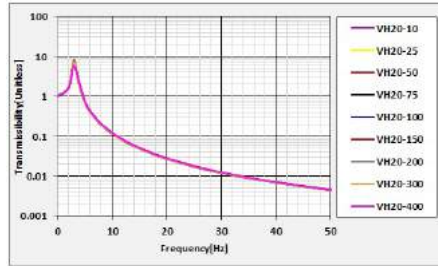
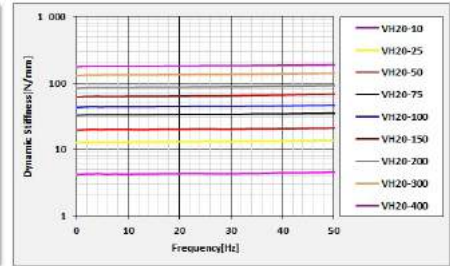
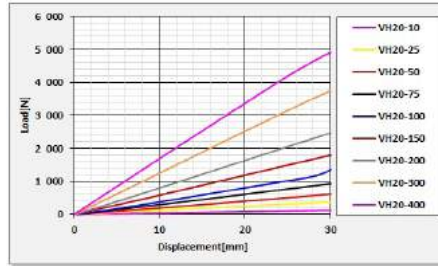

- | | | |
|---|---|-------------------------------|
| 1 | 2 | 1. Load-Displacement Graph |
| | | 2. Dynamic Stiffness Graph |
| 3 | 4 | 3. Transmissibility Graph |
| | | 4. Isolation Efficiency Graph |

■ VH61 Test Data

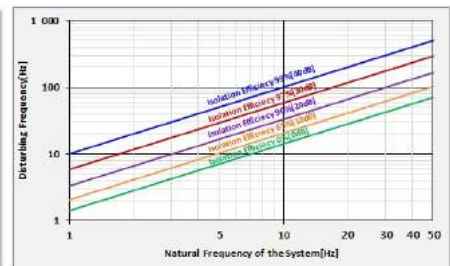
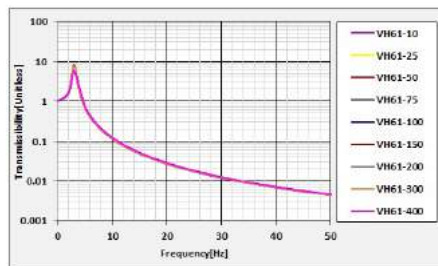
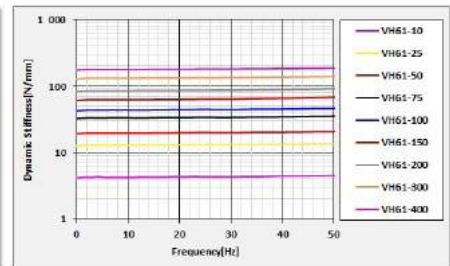
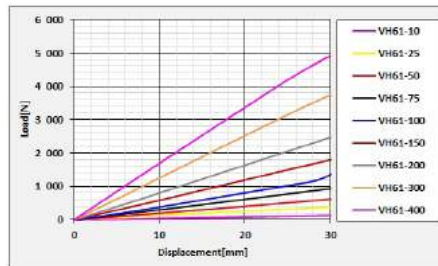

- | | | |
|---|---|-------------------------------|
| 1 | 2 | 1. Load-Displacement Graph |
| | | 2. Dynamic Stiffness Graph |
| 3 | 4 | 3. Transmissibility Graph |
| | | 4. Isolation Efficiency Graph |

■ VH62 Test Data

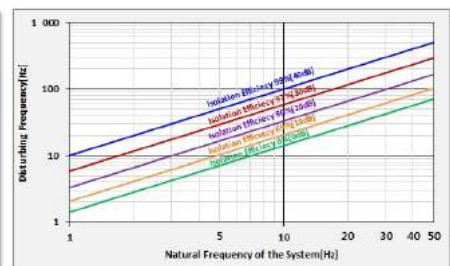
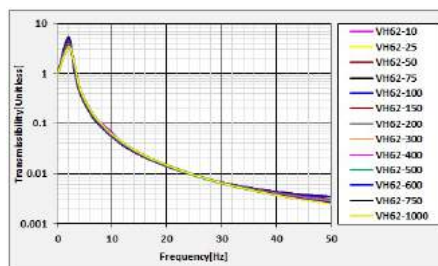
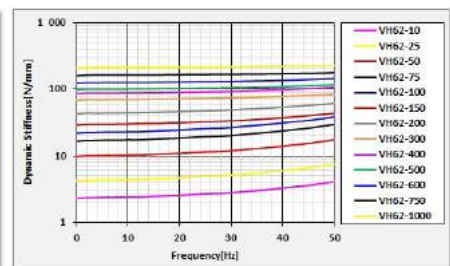
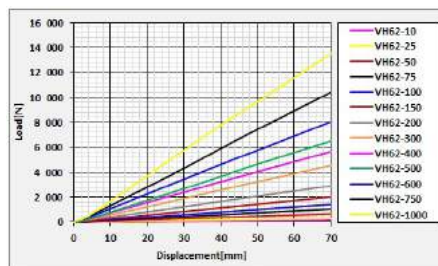

- | | | |
|---|---|-------------------------------|
| 1 | 2 | 1. Load-Displacement Graph |
| | | 2. Dynamic Stiffness Graph |
| 3 | 4 | 3. Transmissibility Graph |
| | | 4. Isolation Efficiency Graph |

RH10 Rubber Hanger (Deflection : 3.5~13mm)

※ The model name of RH product has changed to RH10

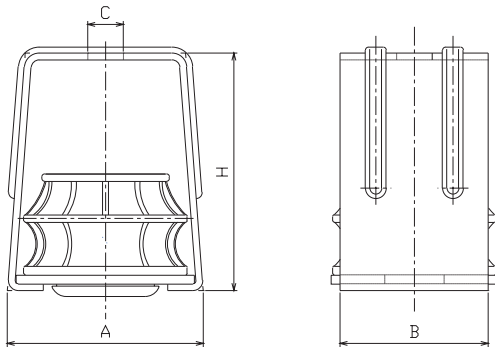

■ Features

RH10 type anti-vibration rubber hanger prevents the transfer of vibration generated from equipment or its parts to the structure, and its housing is strong enough to stand load transferred and avoid resonance. With the open rubber having a static deflection of 3.5~13 mm, it can maintain the system's natural frequency down to 5~12 Hz.

■ Usage

- ◆ For machine rooms, ventilators in air conditioning rooms and ducts
- ◆ For small fan and duct in line fan
- ◆ For structures suspended from the ceiling of, for example, studios and acoustical laboratories
- ◆ For ceiling mounted FCU

■ Dimension & Selection Guide

| Type | Capacity (kgf) | Hardness (Hs) | Deflection (mm) | Weight (kg) | Dimension(mm) | | | | |
|--------|----------------|---------------|-----------------|-------------|---------------|----|-----|-----|--------------|
| | | | | | A | B | C | H | Hanging Bolt |
| RH10-A | 25~100 | 60±5 | 3.5~13 | 0.36 | 65 | 50 | ∅12 | 80 | M10 |
| RH10-B | 150~400 | | 5.0~13 | 0.76 | 91 | 70 | ∅14 | 102 | M12 |
| RH10-C | 500~750 | | 6.7~13 | 1.24 | 105 | 75 | ∅20 | 120 | M16 |

(NOTE) The mentioned size and scale can be altered to improve the quality performance and capacity of the product without any notice.

■ RH10 Test Data

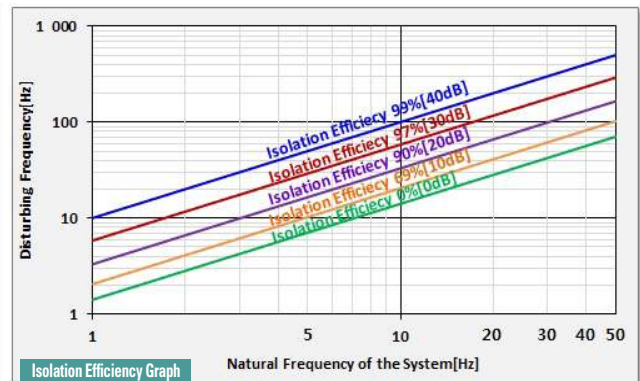
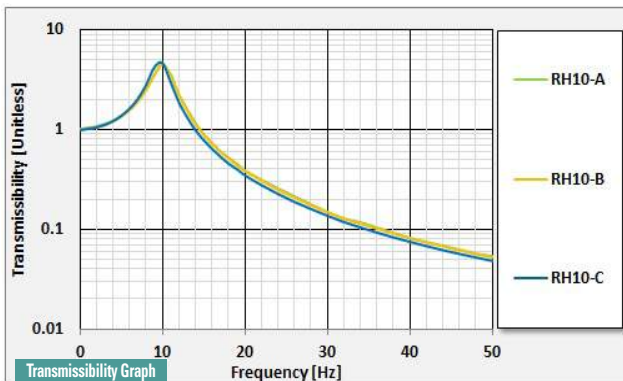
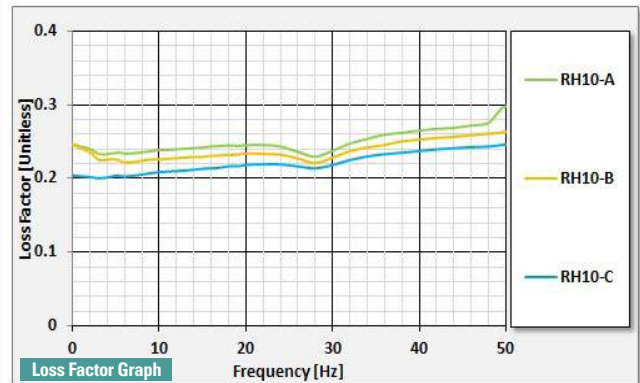
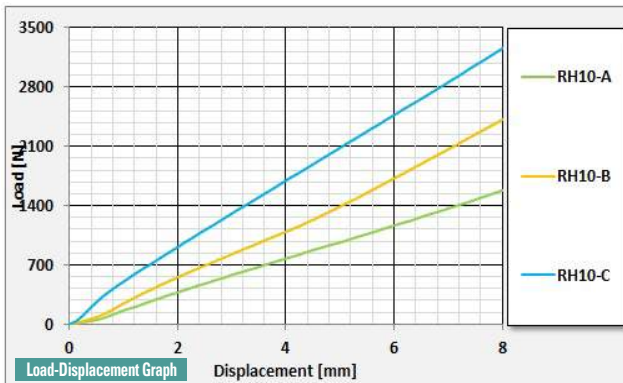

RH20 Ceiling Rubber Hanger (Deflection : 5mm)

※ The model name of CH product has changed to RH20

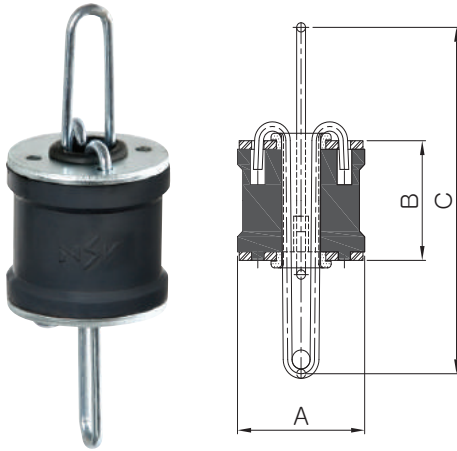

■ Features

It is a vibration-control hanger equipped with galvanized steel inside vibration-proof neoprene rubber. It has two wires at the top and bottom, which are used to suspend objects when a bolt and nut are not available. It has a static deflection of 5.0 mm, capable of keeping the natural vibration down to 7 Hz.

■ Usage

- ◆ For machine rooms, small pipes in air-conditioning room and ducts
- ◆ For structures installed on the ceiling of, for example, studio and acoustical laboratory

■ Dimension & Selection Guide

| Type | Capacity(kgf) | Hardness(Hs) | Weight(kg) | Color(Steel) | Dimension(mm) | | |
|---------|---------------|--------------|------------|--------------|---------------|----|----|
| | | | | | A | B | C |
| RH20-50 | 25~50 | 50±5 | 0.06 | Silver | 35 | 32 | 92 |
| RH20-60 | 45~70 | 60±5 | 0.06 | Gold | | | |

(NOTE) The mentioned size and scale can be altered to improve the quality performance and capacity of the product without any notice.

RH30 Rubber Hanger (Deflection : 3.5~5mm)

※ The model name of VHB product has changed to RH30

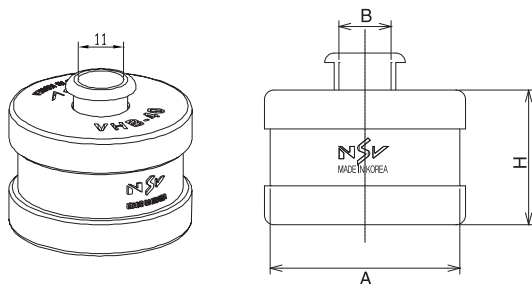

■ Features

The hanger consists of neoprene vibration-proof rubber body where top and bottom are steel capped. It is mainly used as vibration-proof purpose for small fan and pipe duct and its static displacement is 5mm. It can stand the weight of 100kgf.

■ Usage

- ◆ Vibration-proofing for small fan, duct in line fan
- ◆ Vibration-proofing for ceilings of studio, acoustical laboratory, etc.

■ Dimension & Selection Guide

| Type | Capacity (kgf) | Hardness (Hs) | Deflection (mm) | Dimension(mm) | | |
|---------|----------------|---------------|-----------------|---------------|----|----|
| | | | | A | B | H |
| RH30-30 | 30 | 60±5 | 3.5 | 30 | 11 | 18 |
| RH30-40 | 100 | 60±5 | 5.0 | 40 | 11 | 28 |

(NOTE) The mentioned size and scale can be altered to improve the quality performance and capacity of the product without any notice.

RH40 Spring Rubber Hanger (Deflection : 11mm)

※ The model name of VHM product has changed to RH40

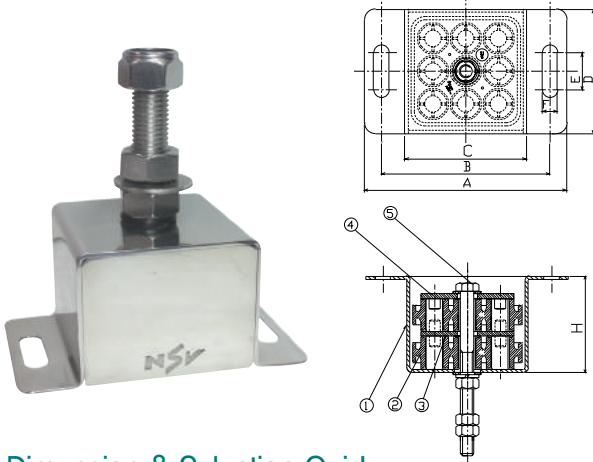

Dimension & Selection Guide

| Type | Capacity (kgf) | Deflection (mm) | Dimension(mm) | | | | | | | Level Bolt |
|-----------|----------------|-----------------|---------------|-----|-----|-----|----|----|-----|------------|
| | | | A | B | C | D | E | F | H | |
| RH40-400 | 400 | 11 | 185 | 154 | 111 | 114 | 34 | 14 | 88 | M20 |
| RH40-600 | 600 | | | | | | | | | |
| RH40-800 | 800 | | | | | | | | | |
| RH40-1000 | 1,000 | | | | | | | | | |
| RH40-1200 | 1,200 | | | | | | | | | |
| RH40-1500 | 1,500 | 240 | 210 | 166 | 170 | 34 | 14 | 88 | M24 | |
| RH40-2000 | 2,000 | | | | | | | | | |

(NOTE) The specification and data are subject to change without prior notice for improvement of product performance and quality.

Features

RH-40 type anti-vibration spring rubber hanger prevents the transfer of vibration generated from equipment and/or stress resulted from thermal expansion in pipes and ducts during operation. A high-elastic alignment product, SRP with combined features of anti-vibration rubber (multi-axis serviceability, high-frequency isolation, soundproofing and attenuation) and metal spring (low natural frequency) is inserted and the external robust, stable housing is made of stainless steel to prevent corrosion when installed outdoors.

Usage

- ◆ For high-efficient vibration control of jet fan, axial, machine rooms, pipes in air conditioning rooms and ducts
- ◆ For high-efficient vibration control of suspended ceiling deck system in, for example, acoustical laboratories and studios

Specification

| No. | Name of Components | Material | Standard |
|-----|--------------------|----------|-----------|
| 1 | Middle Plate | STS 304 | KS D 3503 |
| 2 | SRP Mount | CR | KS M 6617 |
| 3 | Cover Housing | STS 304 | KS D 3503 |
| 4 | Bottom Plate | STS 304 | KS D 3503 |
| 5 | Hanger Bolt/Nut | STS 304 | KS B 3503 |

NBN Rubber Bushing Nut (Deflection : 3~8mm)

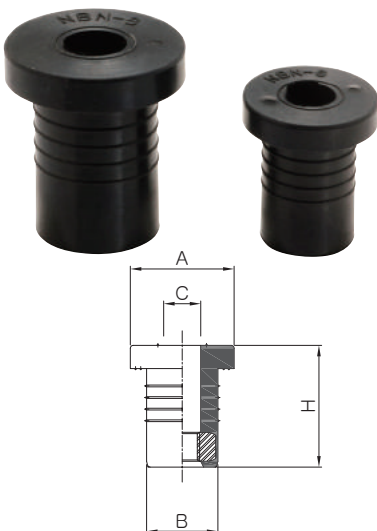

Features

It is used to install equipment that is too small to mount the vibration isolator, and control the vibration of equipment and/or device that causes micro-vibration after being fastened using Bolt and Nut. It is made of anti-vibration neoprene rubber, which seals the joint. Its natural frequency changes according to tightening torque, but it is about 12~15Hz on average. It maintains a vibration isolation efficiency of 67~81% and reduces about 9.5~14.4dB of vibration. (No. of revolution per minute: 1,800 RPM)

Usage

- ◆ Used to fix and control vibration of motors installed on small equipment
- ◆ Used to fix and control vibration of all kinds of pipes, ducts and construction materials
- ◆ Used to fix and control vibration of all kinds of guide signs/posts
- ◆ Used to fix and control vibration of all kinds of lighting
- ◆ Used to fix and control vibration of speakers connected to electronic/audio equipment

Dimension & Selection Guide

| Type | Capacity (kgf) | Applied Diameter (kgf) | Hardness (Hs) | NUT | TORQUE (Kg.cm) | Dimension(mm) | | | |
|--------|----------------|------------------------|---------------|---------|----------------|---------------|------|-----|----|
| | | | | | | A | B | C | H |
| NBN-M3 | 6 | 7~7.4 | 55±5 | M3×0.5 | 3~5 | 9.5 | 6.9 | 3.3 | 12 |
| NBN-M4 | 7 | 9~9.4 | | M4×0.7 | 4~6 | 11.9 | 8.9 | 4.3 | 15 |
| NBN-M5 | 10 | 10~10.4 | | M5×0.8 | 5~8 | 14.9 | 9.9 | 3.3 | 18 |
| NBN-M6 | 15 | 12.4~12.8 | | M6×1.0 | 8~10 | 17.9 | 12.3 | 6.4 | 21 |
| NBN-M8 | 30 | 16.4~16.8 | | M8×1.25 | 10~15 | 23.9 | 16.3 | 8.4 | 27 |

(NOTE) The mentioned size and scale can be altered to improve the quality performance and capacity of the product without any notice.

NTR Thrust Restraint (Deflection : 25mm)

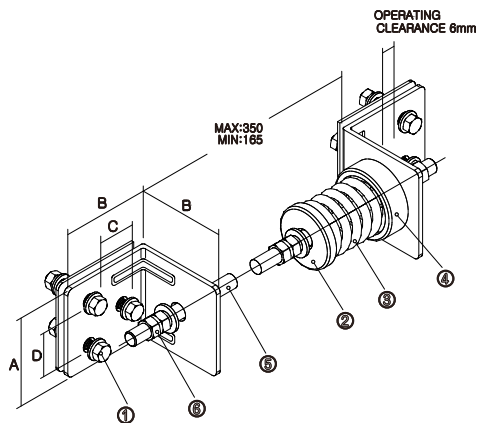
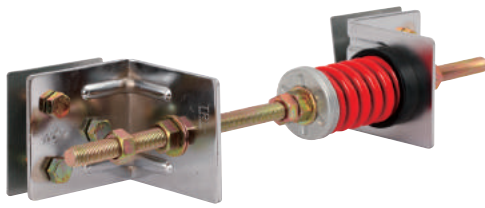

■ Features

NTR, which consists of steel housing, spring, CR type rubber and space rod, is a vibration control device designed to prevent the generation of reactionary force in the direction opposite to air flow when related equipment such as fan and ventilator runs. NTR is preset to 80% of the load capacity in the production stage and users can adjust it up to 6 mm when installing it. It should be installed next to the center of the direction in which the air flows through the duct. Plus, it is easy to distinguish one from another because the springs differ in color depending on their load capacity. In general, NTR is used only when the thrust is more than 5% of the weight of the equipment.

■ Usage

- ◆ Used to prevent thrust on the joint of fan part separating canvas
- ◆ Used to prevent thrust on ventilator(Airfoil Sirocco, Axial, In-line, etc)

■ Specification

| No. | Name of Components | Material | Standard |
|-----|--------------------|----------|-----------|
| 1 | Housing | SS400 | KS D 3503 |
| 2 | Still Cap | SS400 | KS D 3503 |
| 3 | Coil Spring | SUP9 | KS B 2402 |
| | | HSW3 | KS B 2403 |
| 4 | Neoprene Cup | CR | KS M 6617 |
| 5 | Threaded Rod | SS400 | KS D 3503 |
| 6 | Nut | SS400 | KS B 1002 |



■ Dimension & Selection Guide

| Type | Capacity (kgf) | Spring Constant (kgf/mm) | Weight (kg) | Color | Dimension(mm) | | | | |
|----------|----------------|--------------------------|-------------|--------|---------------|-----|----|----|-----------|
| | | | | | A | B | C | H | Space Rod |
| NTR-50 | 50 | 2.0 | 2.35 | Red | 70 | 80 | 40 | 40 | M16 x 470 |
| NTR-75 | 75 | 3.0 | 2.64 | Black | | | | | |
| NTR-100 | 100 | 4.0 | 2.79 | Blue | | | | | |
| NTR-150 | 150 | 6.0 | 3.28 | Brown | | | | | |
| NTR-200 | 200 | 8.0 | 3.35 | White | | | | | |
| NTR-300 | 300 | 12.0 | 3.44 | Orange | | | | | |
| NTR-400 | 400 | 16.0 | 3.51 | Pink | | | | | |
| NTR-500 | 500 | 20.0 | 4.27 | Green | 100 | 100 | 40 | 50 | |
| NTR-600 | 600 | 24.0 | 4.32 | Blue | | | | | |
| NTR-750 | 750 | 30.0 | 4.45 | Black | | | | | |
| NTR-1000 | 1,000 | 40.0 | 4.61 | Yellow | | | | | |

(NOTE) The mentioned size and scale can be altered to improve the quality performance and capacity of the product without any notice.

NTR2 Thrust Restraint (Deflection : 50mm)

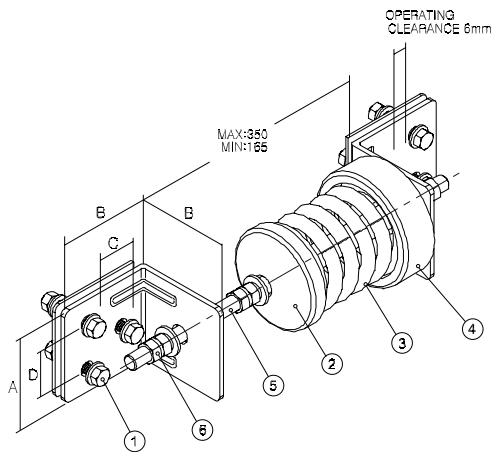
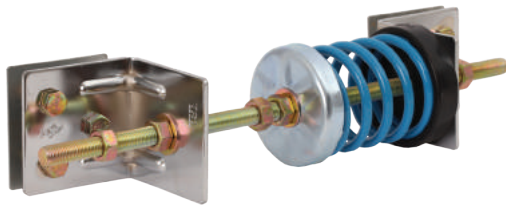

■ Features

NTR, which consists of steel housing, spring, CR type rubber and space rod, is a vibration control device designed to prevent the generation of reactionary force in the direction opposite to air flow when related equipment such as fan and ventilator runs. NTR is preset to 80% of the load capacity in the production stage and users can adjust it up to 6 mm when installing it. It should be installed next to the center of the direction in which the air flows through the duct. Plus, it is easy to distinguish one from another because the springs differ in color depending on their load capacity. In general, NTR is used only when the thrust is more than 5% of the weight of the equipment.

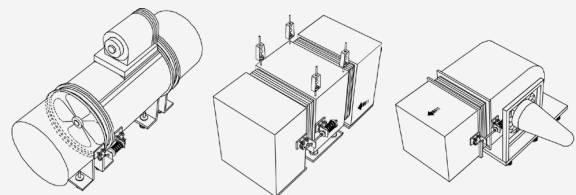

■ Usage

- ◆ Used to prevent thrust on the joint of fan part separating canvas
- ◆ Used to prevent thrust on ventilator(Airfoil, Sirocco, Axial, In-line, etc)

■ Specification

| No. | Name of Components | Material | Standard |
|-----|--------------------|----------|-----------|
| 1 | Housing | SS400 | KS D 3503 |
| 2 | Still Cap | SS400 | KS D 3503 |
| 3 | Coil Spring | SUP9 | KS B 2402 |
| | | HSW3 | KS B 2403 |
| 4 | Neoprene Cup | CR | KS M 6617 |
| 5 | Threaded Rod | SS400 | KS D 3503 |
| 6 | Nut | SS400 | KS B 1002 |

■ Dimension & Selection Guide

| Type | Capacity (kgf) | Spring Constant (kgf/mm) | Deflection (mm) | Color | Dimension(mm) | | | | |
|-----------|----------------|--------------------------|-----------------|--------|---------------|-----|----|----|-----------|
| | | | | | A | B | C | H | Space Rod |
| NTR2-50 | 50 | 1.0 | 50 | Red | 100 | 100 | 40 | 50 | M16 x 470 |
| NTR2-75 | 75 | 1.5 | | Black | | | | | |
| NTR2-100 | 100 | 2.0 | | Blue | | | | | |
| NTR2-150 | 150 | 3.0 | | Brown | | | | | |
| NTR2-200 | 200 | 4.0 | | White | | | | | |
| NTR2-300 | 300 | 6.0 | | Orange | | | | | |
| NTR2-400 | 400 | 8.0 | | Pink | | | | | |
| NTR2-500 | 500 | 10.0 | | Green | | | | | |
| NTR2-600 | 600 | 12.0 | | Blue | | | | | |
| NTR2-750 | 750 | 15.0 | | Black | | | | | |
| NTR2-1000 | 1,000 | 20.0 | | Yellow | | | | | |

(NOTE) The mentioned size and scale can be altered to improve the quality performance and capacity of the product without any notice.

NTR/NTR2 Thrust Restraint

■ NTR Test Data

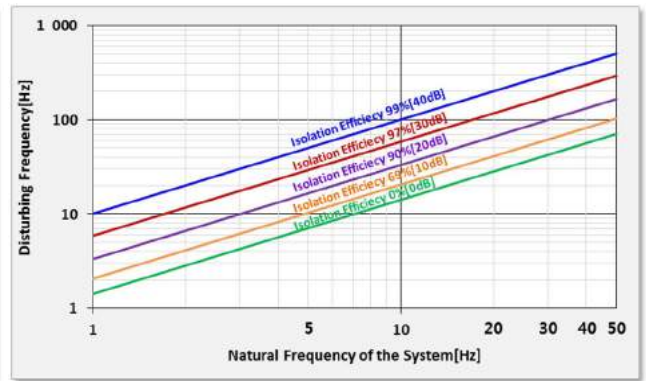
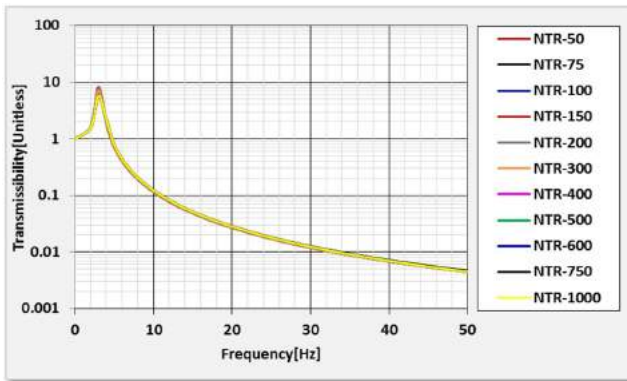
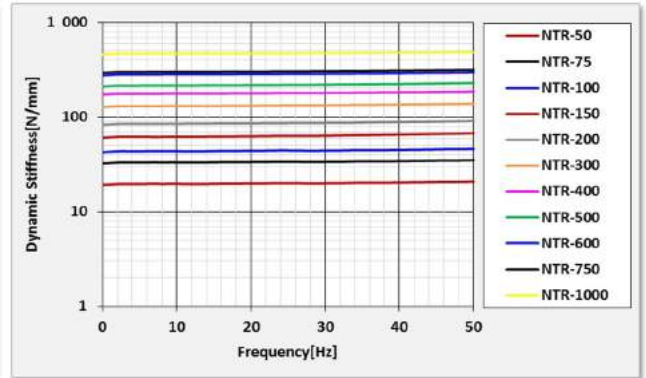
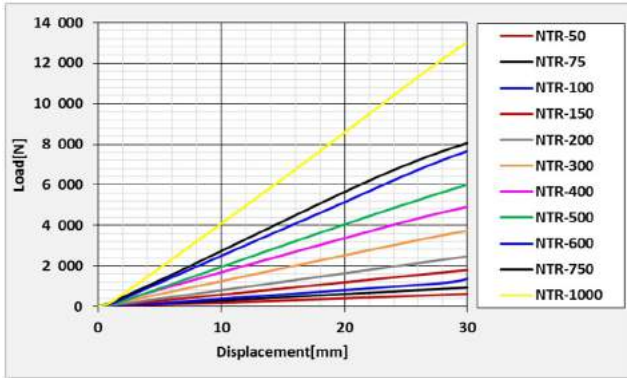

■ NTR2 Test Data

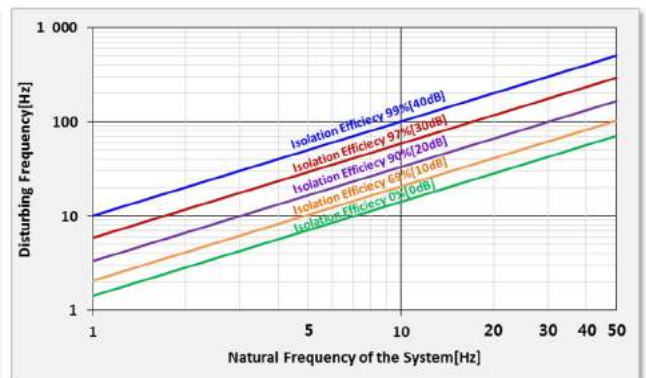
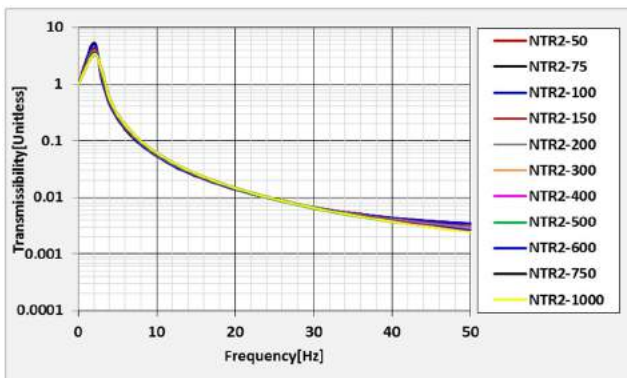
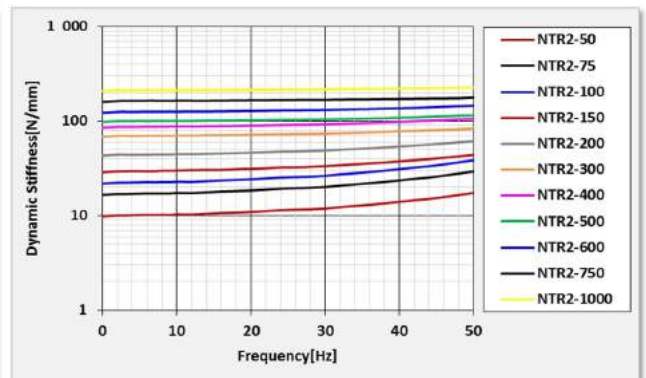
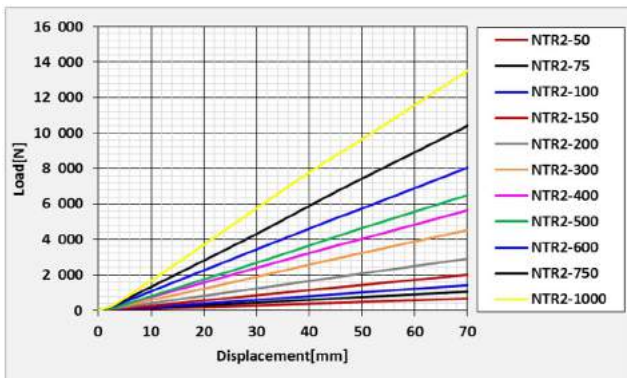

RPA Pipe Anchor & Guide (Deflection : 3~9mm)

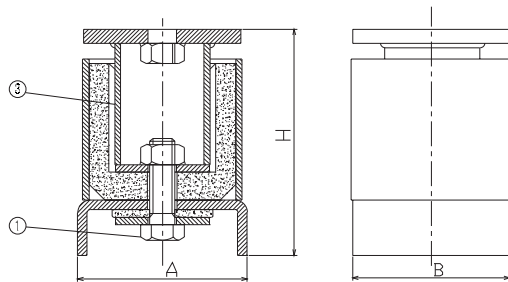
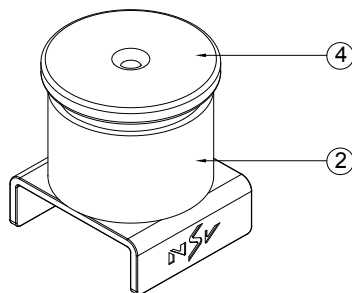

■ Features

With a highly-elastic resilient element inside the steel housing, the product is used as a guide to reduce the stress generated by thermal expansion between floors during the expansion and contraction of vertical pipes and as an anchor to isolate structure-borne noise in both vertical and horizontal directions that has resulted from changes in the fluid pressure. Though the anchor and guide can reduce the amount of noise transferred, they are not elastic enough to isolate the vibration. In such a case, the spring isolated riser system is used to isolate noise as well as vibration. To use the product as a guide, the SRM anti-vibration rubber besides RPA type anchor can be used.

■ Usage

For the anchor and guide used to isolate structure-borne noise from vertical pipe.

■ Specification

| No. | Name of Components | Material | Standard |
|-----|--------------------|----------|-----------|
| 1 | Connection Bolt | SS400 | KS B 1002 |
| 2 | Lower Housing | SS400 | KS D 3503 |
| 3 | Resilient Element | CR | KS M 6617 |
| 4 | Upper Housing | SPCD | KS D 3512 |

■ Dimension & Selection Guide

| Type | Capacity (kgf) | Deflection (mm) | Dimension(mm) | | | |
|---------|----------------|-----------------|---------------|-----|-----|--------------|
| | | | A | B | H | Setting Bolt |
| RPA-75 | 250 | 3 | 75 | 75 | 100 | M12 |
| RPA-200 | 1500 | 5 | 108 | 100 | 140 | M16 |
| RPA-350 | 6000 | 7 | 150 | 140 | 160 | M16 |
| RPA-600 | 14000 | 7 | 230 | 220 | 230 | M20 |
| RPA-800 | 22000 | 9 | 280 | 270 | 360 | M24 |

(NOTE) The mentioned size and scale can be altered to improve the quality performance and capacity of the product without any notice.

■ Installation Features



RPA Pipe Anchor & Guide (Deflection : 3~9mm)

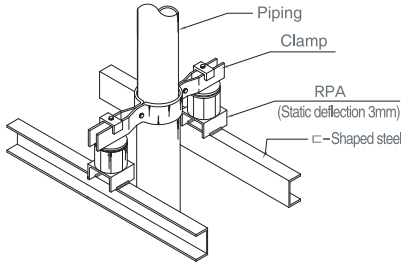

Detailed drawing of pipe anchor

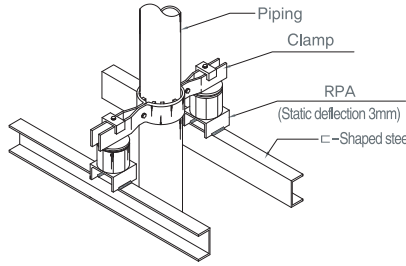

Detailed drawing of pipe guide

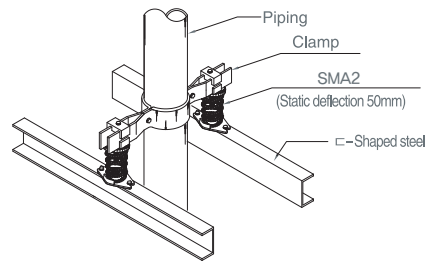

Detailed drawing of pipe spring

INSTALLATION DETAIL

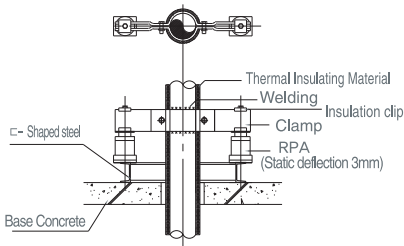

Detailed drawing of pipe anchor

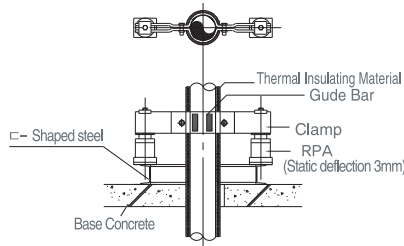

Detailed drawing of pipe guide

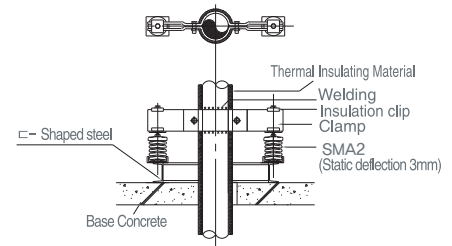

Detailed drawing of pipe spring

< Note >

- Ⓐ: STRAIGHT PIPE: The length between a Guide and Guide D(m)
- Ⓑ: OFFSET PIPE: The length between a Anchor and Guide D(m)
- Ⓒ: The length between a Guide and Expansion Joint D(m)
- Ⓓ: The length between the first Guide and the second Guide D(m)

RPA Anchor & Guide Selection

| Pipe diameter (A) | Anchor Recommendation Size | | | | GUIDE Recommendation Size | | | | | | | | |
|----------------------|----------------------------|--------------------------|---------------|------------|---------------------------|------|-------------|------|-----------------|-----------------------------|--------------------------|--------|-----|
| | EXPANSION THRUST | | OFFSET THRUST | GUIDE SIZE | STRAIGHT PIPE | | OFFSET PIPE | | EXPANSION JOINT | | | | |
| | 12Kg/ cm ² 이하 | 12~24Kg/ cm ² | OFFSET(m) | | Size | Ⓐ | Ⓑ | Ⓒ | Ⓓ | Below 12Kg/ cm ² | 12~24Kg/ cm ² | | |
| 25 | RPA 75 | RPA 75 | 0.20 | RPA 75 | RPA 75 | ② 12 | ① 7 | 0.2 | ① | 0.6 | 3.6 | ① | 3.6 |
| 32 | 75 | 75 | 0.25 | 75 | 75 | 12 | 7 | 0.2 | ① | 0.6 | 3.6 | 3.6 | |
| 40 | 75 | 75 | 0.27 | 75 | 75 | 12 | 7 | 0.25 | ① | 0.9 | 3.6 | 3.6 | |
| 50 | 75 | 75 | 0.29 | 75 | 75 | ② 12 | ② 7 | 0.25 | ② | 0.9 | 3.6 | ② 3.6 | |
| 65 | RPA 75 | RPA 200 | 0.33 | RPA 75 | RPA 75 | 12 | 9 | 0.3 | ① | 1.0 | 3.6 | 3.6 | |
| 80 | 75 | 200 | 0.37 | 75 | 75 | 12 | 11 | 0.3 | ① | 1.0 | 5.1 | 4.2 | |
| 100 | 200 | 200 | 0.42 | 75 | 75 | 12 | 11 | 0.4 | ① | 1.4 | 7.5 | 5.7 | |
| 125 | 200 | 200 | 0.45 | 75 | 75 | ② 15 | ② 11 | 0.6 | ② | 2.0 | 9.0 | ② 6.9 | |
| 150 | RPA 200 | RPA 350 | 0.50 | RPA 200 | RPA 200 | 15 | 11 | 0.6 | ① | 2.0 | 11.1 | 8.1 | |
| 200 | 350 | 350 | 0.56 | 200 | 200 | 15 | 15 | 0.76 | ① | 2.8 | 13.5 | 9.9 | |
| 250 | 350 | 350 | 0.64 | 200 | 200 | ② 18 | ② 18 | 1.0 | ① | 3.6 | 17.4 | 12.6 | |
| 300 | 350 | 600 | 0.69 | 350 | 200 | ② 22 | ② 22 | 1.2 | ① | 4.3 | 18.0 | ② 14.4 | |
| 350 | RPA 350 | RPA 600 | 0.72 | RPA 350 | RPA 350 | 26 | 26 | 1.4 | ② | 5.0 | 21.0 | 15.3 | |
| 400 | 350 | 600 | 0.78 | 350 | 350 | 26 | 26 | 1.6 | ② | 5.7 | 23.0 | 16.8 | |
| 450 | 600 | 800 | 0.83 | 350 | 350 | 26 | 26 | 1.8 | ② | 6.4 | 26.0 | 18.3 | |
| 500 | 600 | 800 | 0.87 | 350 | 350 | ② 36 | ② 26 | 2.0 | ② | 7.1 | 27.0 | ② 19.5 | |
| 600 | RPA 800 | - | - | RPA 600 | RPA 350 | 36 | 36 | 2.4 | ② | 8.5 | 31.0 | 22.5 | |
| 650 | 800 | Special type | - | 600 | 600 | 36 | 36 | 3.0 | ② | 10.0 | 32.0 | 25.5 | |
| 700 | 800 | - | - | 600 | 600 | 36 | 36 | 3.0 | ② | 10.0 | 32.0 | 25.5 | |
| 750 | 800 | - | - | 600 | 600 | ② 36 | ② 36 | 3.0 | ① | 10.0 | 32.0 | ① 25.5 | |

CLAMP Riser Pipe Clamp

■ STEEL/STS CLAMP

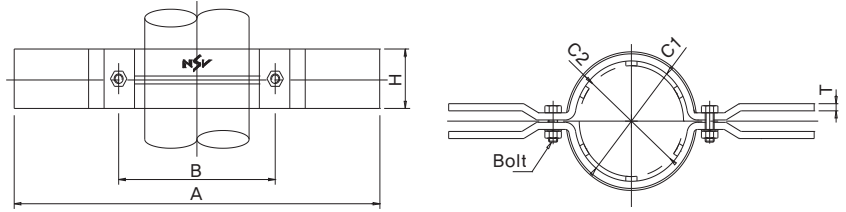
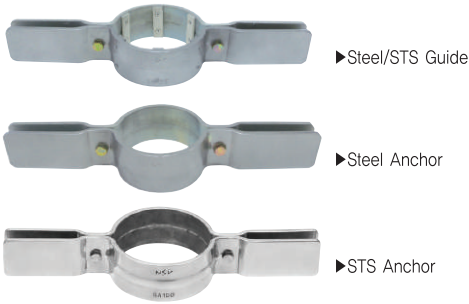

■ CARBON STEEL CLAMP ANCHOR SPRING

| Type | A | B | C1 | T | H | Bolt |
|------|------|-------|--------|-----|-----|------|
| Φ25 | 400 | 71 | Φ34.0 | 4.5 | 38 | M10 |
| Φ32 | | 77 | Φ42.7 | 4.5 | 38 | M10 |
| Φ40 | | 86 | Φ48.6 | 4.5 | 38 | M10 |
| Φ50 | 450 | 105 | Φ60.5 | 6 | 50 | M10 |
| Φ65 | | 125 | Φ76.3 | 6 | 50 | M10 |
| Φ80 | | 137 | Φ89.1 | 6 | 50 | M10 |
| Φ100 | 550 | 171 | Φ114.3 | 9 | 75 | M12 |
| Φ125 | | 197 | Φ139.8 | 9 | 75 | M12 |
| Φ150 | | 230 | Φ165.2 | 9 | 75 | M12 |
| Φ200 | 650 | 281 | Φ216.3 | 9 | 75 | M12 |
| Φ250 | | 332 | Φ267.4 | 9 | 90 | M12 |
| Φ300 | 850 | 416.4 | Φ318.5 | 9 | 90 | M12 |
| Φ350 | | 453.6 | Φ355.6 | 9 | 90 | M12 |
| Φ400 | 1000 | 530.2 | Φ406.4 | 12 | 100 | M22 |
| Φ600 | 1200 | 800 | Φ609.6 | 19 | 125 | M24 |
| Φ800 | 1450 | 1050 | Φ812.8 | 25 | 200 | M36 |

■ CARBON STEEL CLAMP GUIDE

| Type | A | B | C1 | T | H | Bolt | Guide Bar |
|------|------|-------|--------|-----|-----|------|------------------|
| Φ25 | 400 | 73 | Φ43.0 | 4.5 | 38 | M10 | 20x38x4.5T(2EA) |
| Φ32 | | 82 | Φ51.7 | 4.5 | 38 | M10 | 20x38x4.5T(4EA) |
| Φ40 | | 88 | Φ57.6 | 4.5 | 38 | M10 | 20x38x4.5T(4EA) |
| Φ50 | 450 | 106 | Φ69.5 | 6 | 50 | M10 | 20x50x4.5T(6EA) |
| Φ65 | | 124 | Φ85.3 | 6 | 50 | M10 | 20x50x4.5T(6EA) |
| Φ80 | | 134 | Φ98.1 | 6 | 50 | M10 | 20x50x4.5T(6EA) |
| Φ100 | 550 | 171 | Φ126.3 | 9 | 75 | M12 | 20x75x6T(6EA) |
| Φ125 | | 197 | Φ141.8 | 9 | 75 | M12 | 20x75x6T(6EA) |
| Φ150 | | 222 | Φ177.2 | 9 | 75 | M12 | 20x75x6T(6EA) |
| Φ200 | 650 | 281 | Φ228.3 | 9 | 75 | M12 | 20x90x6T(8EA) |
| Φ250 | | 332 | Φ279.4 | 9 | 90 | M12 | 20x90x6T(8EA) |
| Φ300 | 850 | 416.4 | Φ330.5 | 9 | 90 | M12 | 20x90x6T(10EA) |
| Φ350 | | 453.6 | Φ367.6 | 9 | 90 | M12 | 20x90x6T(10EA) |
| Φ400 | 1000 | 530.2 | Φ426.4 | 12 | 100 | M22 | 40x95x10T(8EA) |
| Φ600 | 1200 | 800 | Φ629.6 | 19 | 125 | M24 | 40x120x10T(10EA) |
| Φ800 | 1450 | 1050 | Φ832.8 | 25 | 200 | M36 | 40x198x12T(12EA) |

■ COPPER CLAMP



■ COPPER CLAMP ANCHOR, SPRING

| Type | A | B | C1 | T | H | Bolt |
|------|-----|-----|---------|-----|----|------|
| Φ25 | 400 | 72 | Φ28.58 | 4.5 | 38 | M10 |
| Φ32 | | 72 | Φ34.92 | 4.5 | 38 | M10 |
| Φ40 | | 79 | Φ41.28 | 4.5 | 38 | M10 |
| Φ50 | 450 | 99 | Φ53.98 | 6 | 50 | M10 |
| Φ65 | | 114 | Φ66.68 | 6 | 50 | M10 |
| Φ80 | | 126 | Φ79.38 | 6 | 50 | M10 |
| Φ100 | 550 | 161 | Φ104.78 | 8 | 75 | M12 |
| Φ125 | | 182 | Φ130.18 | 8 | 75 | M12 |
| Φ150 | | 207 | Φ155.58 | 8 | 75 | M12 |
| Φ200 | 650 | 274 | Φ206.38 | 8 | 75 | M12 |

■ Installation Features



CLAMP Riser Pipe Clamp

CLAMPING Installation Features

COPPER PIPE



WITH ANCHOR(Before welding)



WITH SPRING(Before welding)



WITH GUIDE



WITH SPRING RUBBER MOUNT(Before welding)

CARBON STEEL/STS PIPE



WITH ANCHOR(Before welding)



WITH SPRING(Before welding)



WITH GUIDE



WITH SPRING RUBBER MOUNT(Before welding)

VB-1000 Rubber Mount (Deflection : 5.0~9.0mm)

※ The model name of VB product has changed to VB-1000

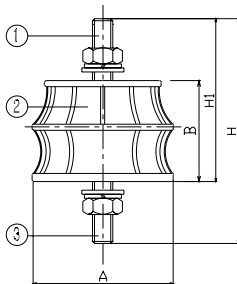

■ Features

As a Bobbin (cylindrical) mount, it has the reinforcing of a steel plate on the top and bottom. It is excellent in reducing vibration and structure-borne noise resulting from impact. It is made of neoprene synthetic rubber, having outstanding oil and ozone resistance, and with the fixing rod on the top and bottom, it can be easily fastened using a nut.

■ Usage

- ◆ For small pumps, small ventilators, package air conditioning systems and plant rooms
- ◆ For all kinds of industrial machines and equipment

■ Specification

| No. | Name of Components | Material | Standard |
|-----|--------------------|----------|-----------|
| 1 | Bolt(upper) | SS400 | KS B 1002 |
| 2 | Rubber Mount | CR | KS M 6617 |
| 3 | Bolt(lower) | SS400 | KS B 1002 |

■ Dimension & Selection Guide

| Type | Capacity(kgf) | Hardness(Hs) | Deflection(mm) | Dimension(mm) | | | | |
|---------|---------------|--------------|----------------|---------------|----|-----|-----|--------|
| | | | | A | B | H | H1 | Bolt |
| VB-1040 | 50 | 60±5 | 5.0 | 40 | 35 | 87 | 60 | M8X30 |
| VB-1050 | 70 | | | 50 | 40 | 92 | 65 | M8X30 |
| VB-1060 | 100 | | | 60 | 40 | 100 | 70 | M10X35 |
| VB-1070 | 180 | | 7.0 | 70 | 50 | 110 | 80 | M10X35 |
| VB-1080 | 300 | | | 80 | 50 | 110 | 80 | M10X35 |
| VB-1100 | 500 | | | 100 | 55 | 124 | 90 | M12X40 |
| VB-1120 | 800 | | 9.0 | 120 | 55 | 124 | 90 | M16X40 |
| VB-1150 | 1000 | | | 150 | 60 | 150 | 105 | M16X50 |

(NOTE) The mentioned size and scale can be altered to improve the quality performance and capacity of the product without any notice.

VB-1030H Rubber Oval Mount (Deflection : 5.0~9.0mm)

※ The model name of VBO-30 product has changed to VB-1030H

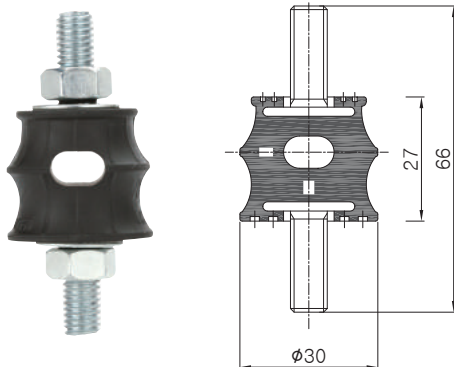

■ Features

The VB-1030H is a rubber mount with an increased static deflection and Oval hole at the center to maintain the stable operation of the equipment against horizontal vibration. It has the hardness of 55±5 and with the M8 bolt, it can load up to 25kgf.

■ Usage

- ◆ For small pumps and small ventilators
- ◆ For small motors and measurement equipment

■ Dimension & Selection Guide

| Type | Capacity(kgf) | Hardness(Hs) | Deflection(mm) | Dimension(mm) | | | | |
|----------|---------------|--------------|----------------|---------------|----|----|----|-------|
| | | | | A | B | H | H1 | Bolt |
| VB-1030H | 30 | 60±5 | 5.0 | 30 | 27 | 66 | - | M8X30 |

(NOTE) The mentioned size and scale can be altered to improve the quality performance and capacity of the product without any notice.

VB-1000/VB-1030H Rubber Mount

■ VB-1000 Test Data

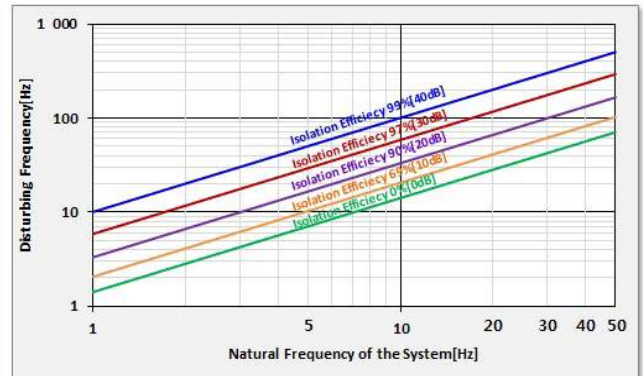
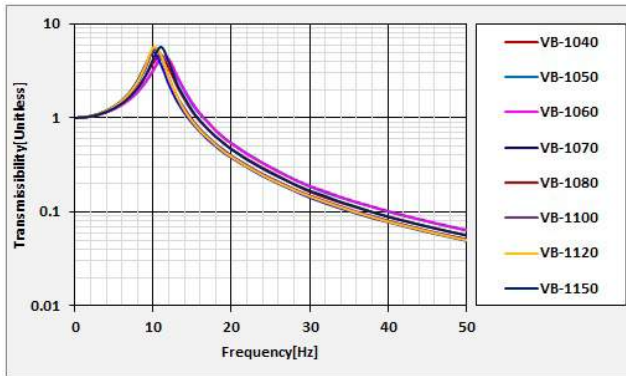
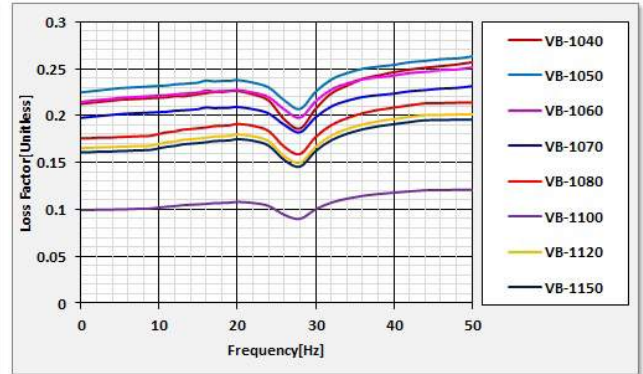
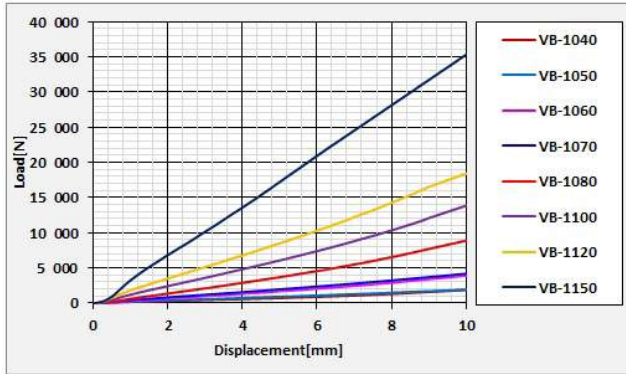

■ VB-1030H Test Data

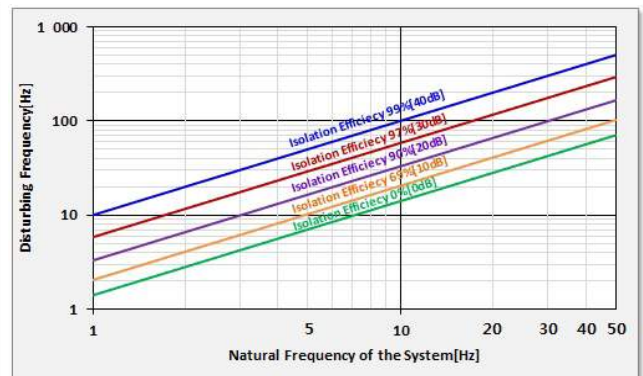
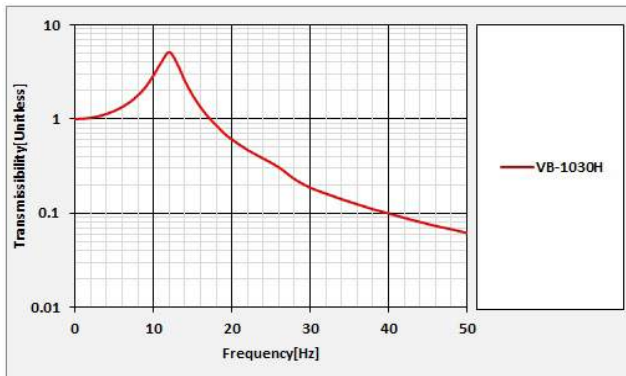
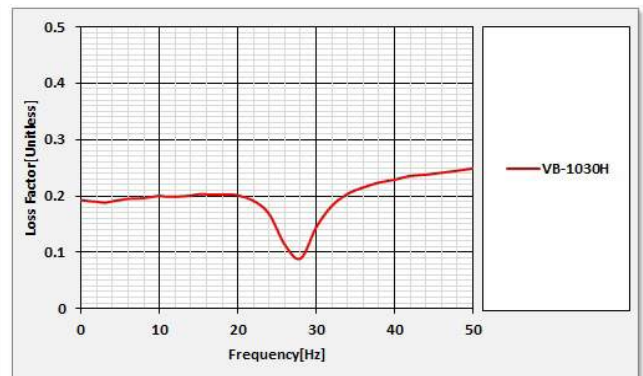
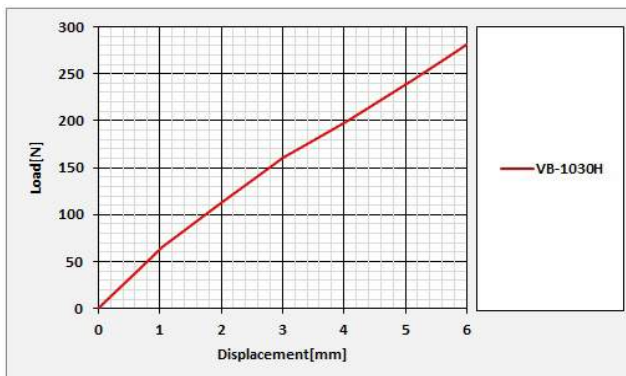

VB-2000 Rubber Mount (Deflection : 11~20mm)

※ The model name of VO product has changed to VB-2000

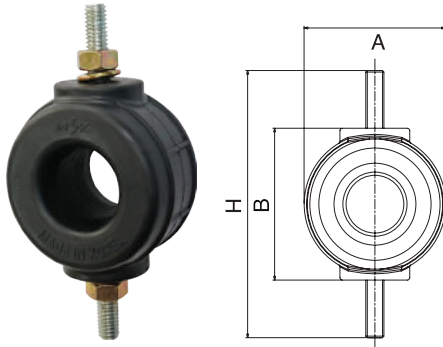

■ Features

For VB-2000 rubber mount product, Oval hole is inserted into its center, to increase static displacement for light load, and to maintain stable transformation against horizontal vibration. Hardness of rubber mount is 60 ± 5 , and is manufactured using neoprene synthetic rubber with excellent oil resistance and ozone-proof features.

■ Usage

- ◆ Mini-pump, mini air blower dust protection
- ◆ Small sized motor and measuring equipment dust protection

■ Dimension & Selection Guide

| Type | Capacity(kgf) | Spring Constant(kgf/mm) | Deflection(mm) | Dimension(mm) | | | |
|--------|---------------|-------------------------|----------------|---------------|----|----|------------|
| | | | | A | B | H | Level Bolt |
| VB2025 | 10.0 | 0.9 | 11 | 25 | 26 | 54 | M5x15 |
| VB2035 | 16.7 | 1.0 | 17 | 36 | 38 | 66 | M5x15 |
| VB2045 | 33.9 | 1.7 | 17 | 47 | 50 | 88 | M6x20 |

(NOTE) The mentioned size and scale can be altered to improve the quality performance and capacity of the product without any notice.

VM-1000 Rubber Mount (Deflection : 6~8mm)

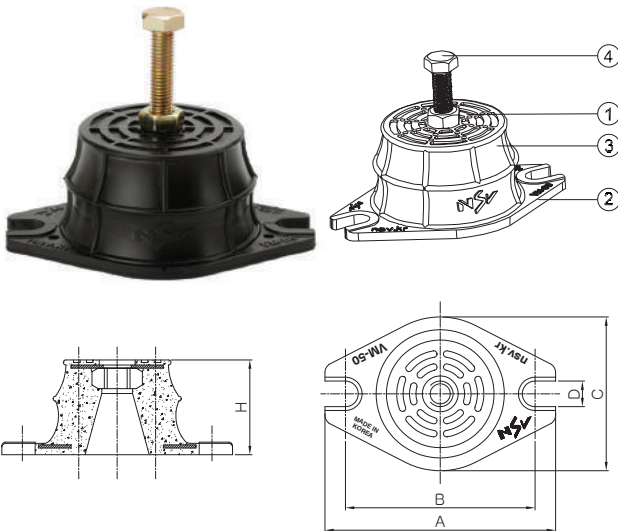

■ Features

A VM-1000 mount is light, small and easy to install, so it can be used in high displacements. Plus, it has a wide application because it is designed to ensure structural stability. With a fixing nut inside the center of the neoprene rubber mount and steel plate on the top and bottom, it can be securely anchored to the ground.

■ Specification

| No. | Name of Components | Material | Standard |
|-----|--------------------|----------|-----------|
| 1 | Upper Housing | SS400 | KS D 3503 |
| 2 | Lower Plate | SS400 | KS D 3503 |
| 3 | Body | CR | KS M 6617 |
| 4 | Level Bolt | SS400 | KS D 3503 |

■ Dimension & Selection Guide

| Type | Capacity(kgf) | Hardness(Hs) | Deflection(mm) | Weight(kg) | Dimension(mm) | | | | | |
|---------|---------------|--------------|----------------|------------|---------------|-----|-----|----|----|------------|
| | | | | | A | B | C | D | H | Level Bolt |
| VM-1040 | 60 | 60±5 | 6 | 0.18 | 75 | 60 | 46 | 8 | 35 | M8 |
| VM-1050 | 80 | | 6 | 0.21 | 90 | 74 | 60 | 10 | 40 | M10 |
| VM-1060 | 120 | | 6 | 0.31 | 113 | 90 | 69 | 10 | 45 | M10 |
| VM-1070 | 150 | | 6 | 0.34 | 130 | 105 | 81 | 12 | 50 | M10 |
| VM-1080 | 300 | | 8 | 0.42 | 130 | 110 | 90 | 12 | 50 | M10 |
| VM-1100 | 600 | | 8 | 1.78 | 169 | 140 | 112 | 13 | 60 | M12 |

(NOTE) The mentioned size and scale can be altered to improve the quality performance and capacity of the product without any notice.

VM-2000 Rubber Mount(Deflection : 8mm)

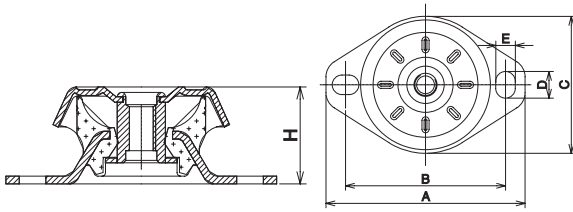
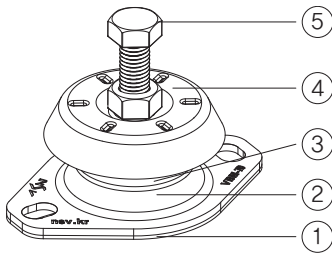

■ Features

VM-2000 mount is a vibration isolator to easily control multi-axial vibration. Its inside is made of neoprene rubber to control excessive movement. At the center of rubber mounts there is a solid fixation nut, and the body was made of steel plate to fix firmly to the floor.

■ Specification

| No. | Name of Components | Material | Standard |
|-----|--------------------|----------|-----------|
| 1 | Non Skid Pad | CR | KS M 6617 |
| 2 | Lower Housing | SS400 | KS D 3503 |
| 3 | Body | CR | KS M 6617 |
| 4 | Upper Housing | SS400 | KS D 3503 |
| 5 | Level Bolt | SS400 | KS B 1002 |

■ Dimension & Selection Guide

| Type | Capacity (kgf) | Deflection (mm) | Hardness (Hs) | Weight (kg) | Dimension(mm) | | | | | | |
|---------|----------------|-----------------|---------------|-------------|---------------|-----|-----|-----|----|----|------------|
| | | | | | A | B | C | D | E | H | Level Bolt |
| VM-2070 | 100 | 6 | 60±5 | 0.34 | 112 | 90 | 77 | 15 | 11 | 40 | M12 |
| VM-2080 | 300 | | | 0.73 | 135 | 110 | 90 | 17 | 13 | 45 | M12 |
| VM-2100 | 500 | | | 1.22 | 164 | 135 | 105 | 21 | 13 | 50 | M16 |
| VM-2120 | 1000 | | | 1.56 | 190 | 161 | 128 | 21 | 18 | 55 | M16 |
| VM-2150 | 1500 | | | 2.18 | 200 | 160 | 150 | 110 | 18 | 60 | M20 |
| VM-2180 | 2000 | | | 2.55 | 228 | 186 | 184 | 142 | 18 | 70 | M20 |

(NOTE) The mentioned size and scale can be altered to improve the quality performance and capacity of the product without any notice.

VM-3000 Rubber Mount(Deflection : 6mm)

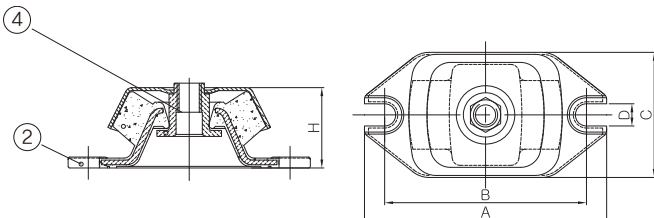
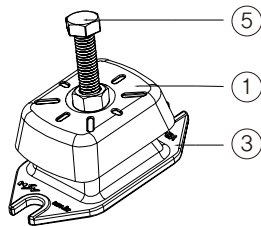

■ Features

A VM-3000 mount is capable of controlling vibration in multi-axis directions. The top stainless steel cap prevents a distortion of the vibration isolator by oil and water, and moreover, neoprene rubber is used inside to control excessive movement. Plus, it can be firmly fixed to the ground with the fixing nut inside the center of the neoprene rubber mount and steel plate on top and bottom.

■ Specification

| No. | Name of Components | Material | Standard |
|-----|--------------------|----------|-----------|
| 1 | Upper Housing | STS 304 | KS D 3698 |
| 2 | Lower Plate | SS400 | KS D 3503 |
| 3 | Body (Rubber) | CR | KS M 6617 |
| 4 | Fix Nut | SS400 | KS D 3503 |
| 5 | Lever Bolt | SS400 | KS B 1002 |

■ Dimension & Selection Guide

| Type | Capacity(kgf) | Hardness(Hs) | Weight(kg) | Dimension(mm) | | | | | |
|---------|---------------|--------------|------------|---------------|-----|-----|----|----|------------|
| | | | | A | B | C | D | H | Level Bolt |
| VM-3060 | 100 | 60±5 | 0.24 | 120 | 100 | 62 | 11 | 45 | M12 |
| VM-3070 | 300 | | 0.72 | 150 | 126 | 78 | 13 | 50 | M12 |
| VM-3090 | 500 | | 1.8 | 180 | 150 | 94 | 16 | 60 | M16 |
| VM-3110 | 700 | | 2.45 | 226 | 189 | 118 | 19 | 70 | M16 |

(NOTE) The mentioned size and scale can be altered to improve the quality performance and capacity of the product without any notice.

VM-4000 Rubber Mount (Deflection : 6~16mm)

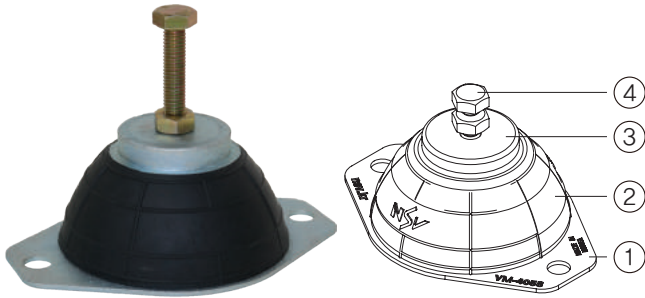

■ Features

VM-4000 mounts is specifically designde to give large deflection at low loads. Although the mount design allows high deflection, the mountings are compact in weigh and easy to install. Provides passive vibration isolation on electronic instruments, measuring equipment and test cells.

■ Specification

| No. | Name of Components | Material | Standard |
|-----|--------------------|----------|-----------|
| 1 | Lower Plate | SS400 | KS D 3503 |
| 2 | Body | CR | KS M 6617 |
| 3 | Upper Plate | SS400 | KS D 3503 |
| 4 | Level Bolt | SS400 | KS B 1002 |

VM-4053
VM-4058

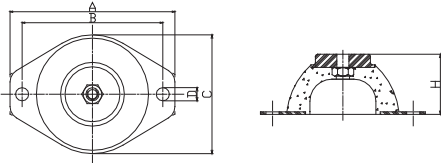

VM-4078
VM-4100

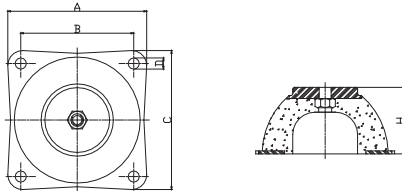

■ Dimension & Selection Guide

| Type | Capacity (kgf) | Hardness (Hs) | Weight (kg) | Dimension(mm) | | | | | |
|---------|----------------|---------------|-------------|---------------|-----|-----|----|------|------------|
| | | | | A | B | C | D | H | Level Bolt |
| VM-4053 | 80 | 45 | 6 | 138 | 100 | 99 | 11 | 46.7 | M12 |
| VM-4058 | 100 | | 9 | 150 | 126 | 108 | 12 | 54.7 | M12 |
| VM-4078 | 300 | | 12 | 150 | 150 | 150 | 13 | 71.8 | M14 |
| VM-4100 | 500 | | 16 | 200 | 189 | 200 | 19 | 93.8 | M18 |

(NOTE) The mentioned size and scale can be altered to improve the quality performance and capacity of the product without any notice.

VM-5000 Rubber Mount (Deflection : 15mm)

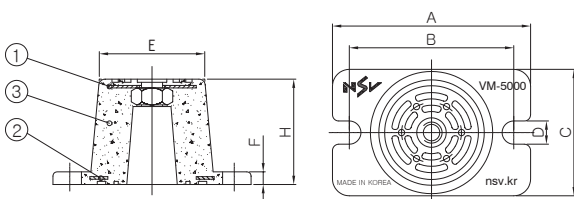
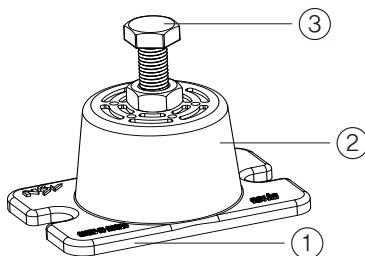

■ Features

It is a mount with top and bottom reinforcing plates made of CR (neoprene) type synthetic rubber having excellent oil and ozone resistance. A round-shaped rib line is on the top and bottom of the mount to prevent slipping from the equipment and the guide hole for anchoring is on the base plate for easier installation. It is simple, but has the largest static deflection, which makes it the most efficient anti-vibration mount with a wide range of applications.

■ Specification

| No. | Name of Components | Material | Standard |
|-----|--------------------|----------|-----------|
| 1 | Base Plate | SS400 | KS D 3503 |
| | | CR | KS M 6617 |
| 2 | Body | CR | KS M 6617 |
| 3 | Level Bolt | SS400 | KS B 1002 |

■ Dimension & Selection Guide

| Type | Capacity (kgf) | Hardness (Hs) | Spring Constant (kg/mm) | Weight (kg) | Dimension(mm) | | | | | | | |
|---------|----------------|---------------|-------------------------|-------------|---------------|-----|-----|----|-----|---|------|------------|
| | | | | | A | B | C | D | E | F | H | Level Bolt |
| VM-5050 | 300 | 60±5 | 20 | 0.26 | 94 | 78 | 60 | 11 | 50 | 6 | 46.7 | M12 |
| VM-5065 | 500 | | 34 | 0.52 | 122 | 102 | 82 | 13 | 66 | 8 | 54.7 | M12 |
| VM-5085 | 1000 | | 67 | 0.84 | 150 | 128 | 104 | 13 | 87 | 8 | 71.8 | M14 |
| VM-5115 | 2000 | | 133 | 1.54 | 188 | 164 | 130 | 14 | 114 | 8 | 93.8 | M18 |

(NOTE) The mentioned size and scale can be altered to improve the quality performance and capacity of the product without any notice.

VM-1000/VM-3000 Rubber Mount

VM-1000 Test Data

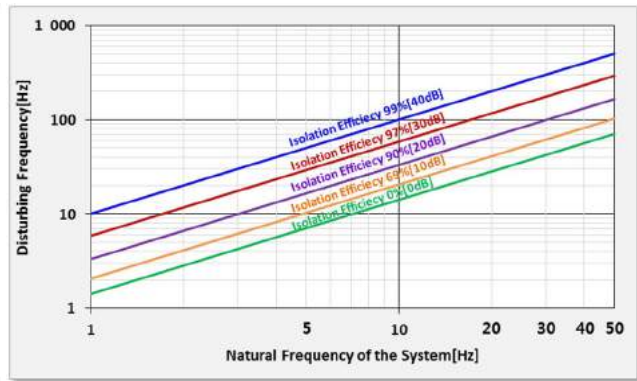
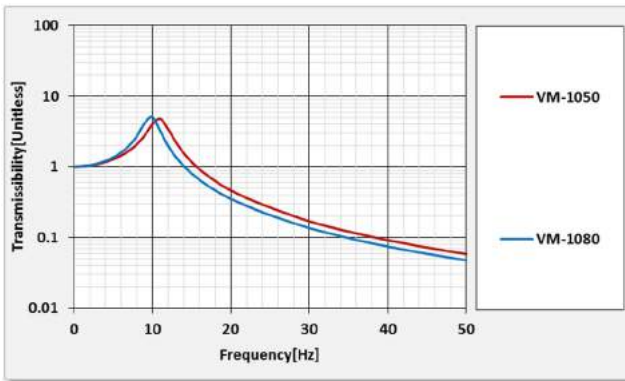
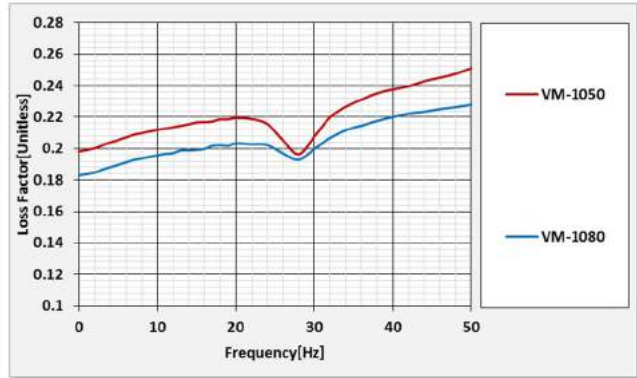
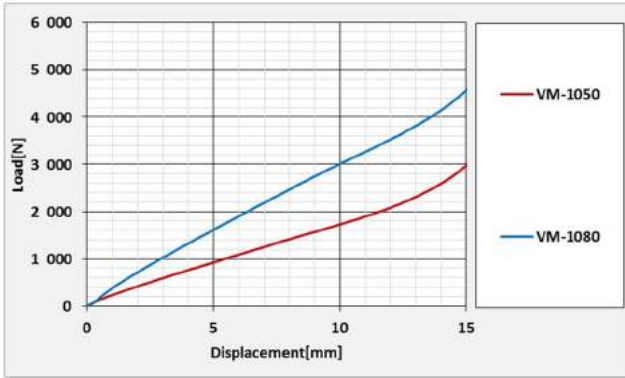

VM-3000 Test Data

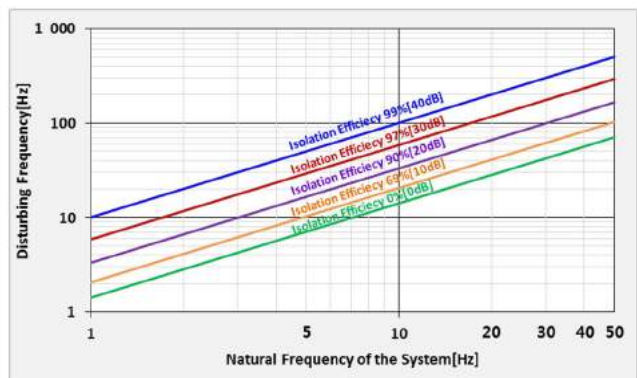
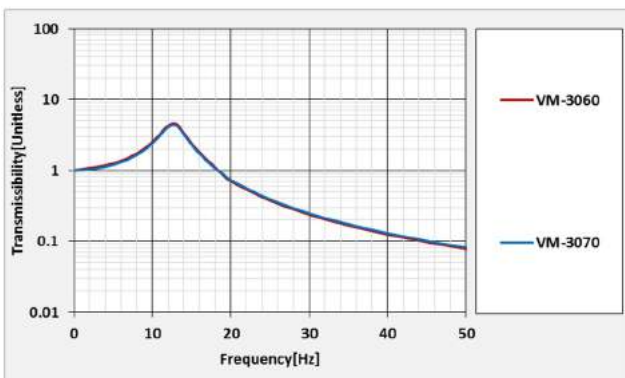
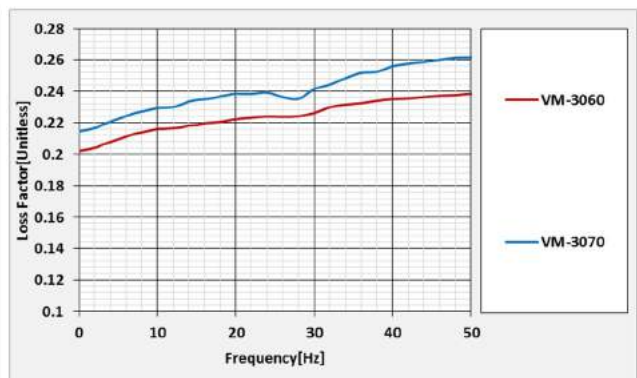
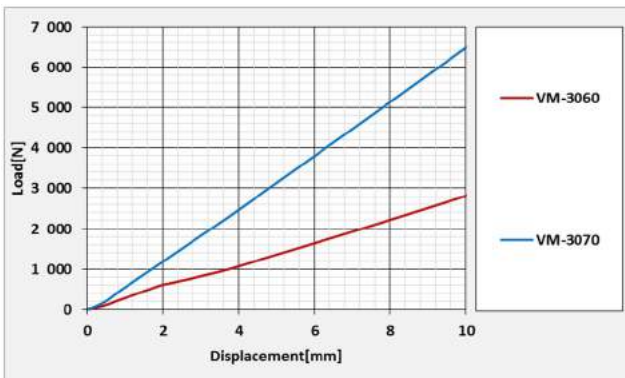

VM-5000 Rubber Mount

VM-5000 Test Data

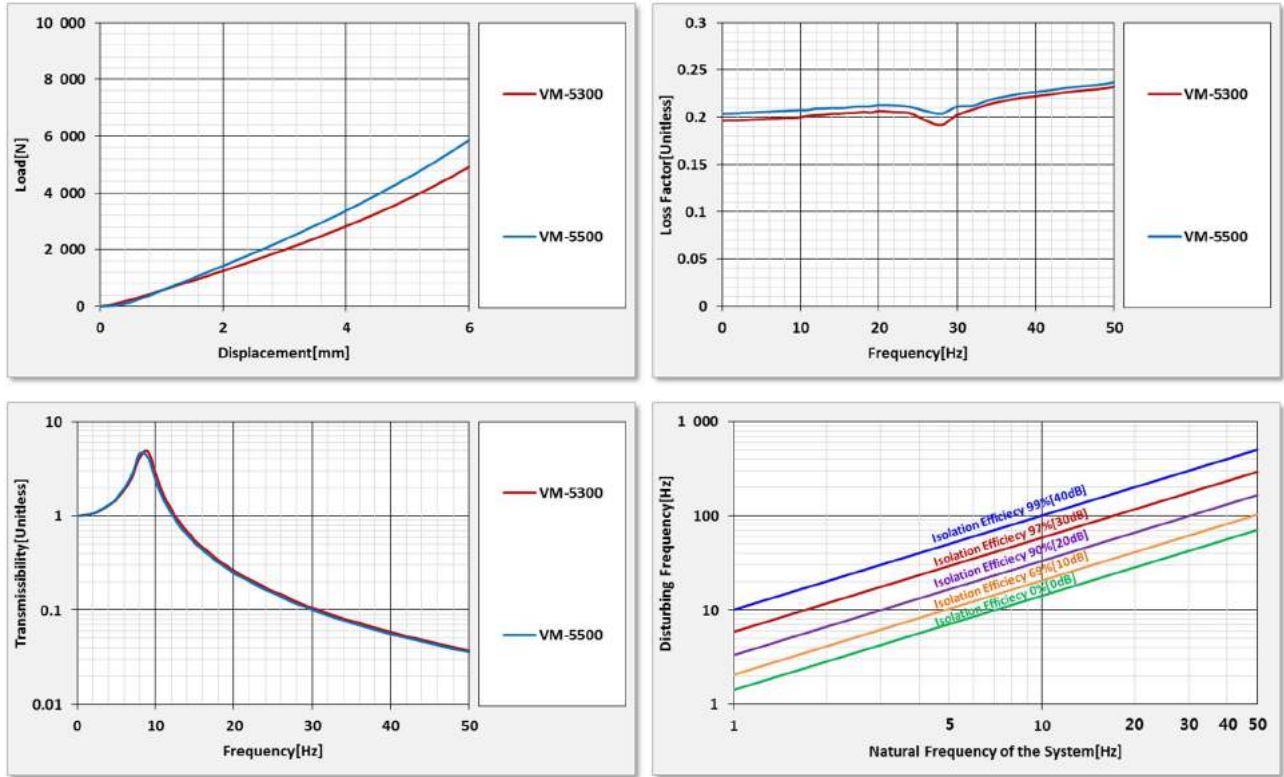

Explanation(Commonness)

1. Vibration Transmissibility(T_r)

Vibration Transmissibility is the amplitude ratio of Output to Input.

$$T_r = \frac{\text{Output Amplitude}}{\text{Input Amplitude}} = \sqrt{\left(\frac{1}{1-\eta^2}\right)^2} \cdot \eta = \frac{\text{Disturbing Frequency of the equipment}}{\text{Natural Frequency of the Isolator (Damping } c = 0)}$$

2. Natural Frequency(F_n) of Vibration Isolation System

The mass and spring stiffness dictate a natural frequency of the system.

$$F_n = \frac{1}{2\pi} \sqrt{\frac{k}{m}}$$

3. Isolation Efficiency(E)

Isolation Efficiency in percent transmission is related to Vibration Transmissibility $E = 100(1 - T_r)$

ex) Disturbing Frequency of the equipment=100 Hz,

Natural Frequency of the isolator=10Hz

$$T_r = \sqrt{\left(\frac{1}{1-\eta^2}\right)^2} = \sqrt{\left(\frac{1}{1-\left(\frac{100}{10}\right)^2}\right)^2} = 0.101 \quad E = 100(1 - T_r) = 100(1-0.101)=99(\%)$$

Installation Features

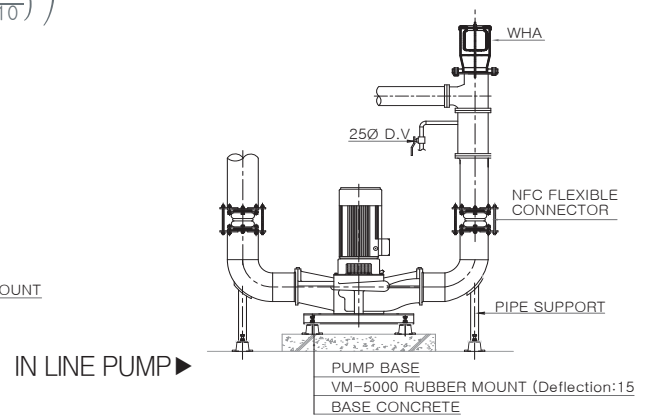
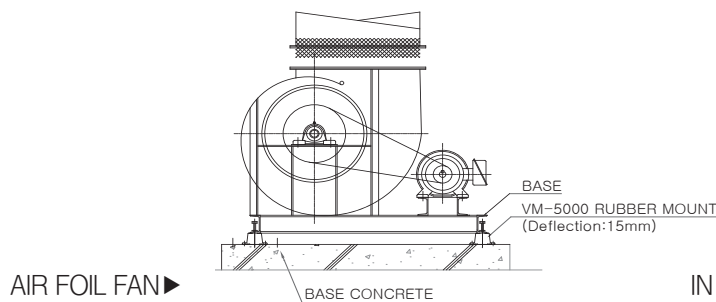

VC Conical Mount (Deflection : 15mm)

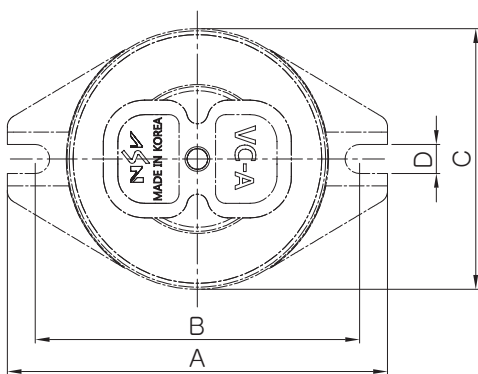
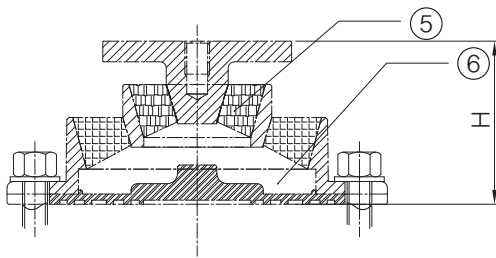
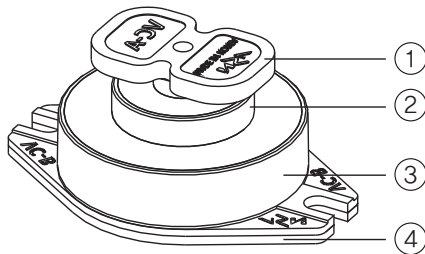

■ Features

The VC conical mount is a special vibration isolator having lower natural frequency (4.5 Hz) than the common rubber mount. Polyurethane or special synthetic neoprene rubber is inside VC conical mount, which makes it highly efficient, even in a low-frequency area. The anti-vibration pad is made of neoprene and is attached on the top and bottom of the contact surfaces to prevent structure-borne from passing through the bottom of the equipment when it touches steel and/or concrete. Plus, it is an omnidirectional vibration isolator, enabling stable operation of the equipment.

■ Usage

- ◆ For pumps, refrigerators, compressors and power generators
- ◆ For ventilators and air conditioning units
- ◆ For cooling towers
- ◆ For equipment having a large horizontal reaction

■ Specification

| No. | Name of Components | Material | Standard |
|-----|--------------------|----------|-----------|
| 1 | Upper Housing | GC | KS D 4301 |
| 2 | Middle Housing | GC | KS D 4301 |
| 3 | Lower Housing | GC | KS D 4301 |
| 4 | Upper Rubber | CR | KS M 6617 |
| 5 | Elastomer#1 | PU or CR | KS M 6617 |
| 6 | Elastomer#2 | PU or CR | KS M 6617 |

■ Installation Features



■ Dimension & Selection Guide

| Type | Capacity (kgf) | Weight (kg) | Hardness (Hs) | Color | Dimension(mm) | | | | | |
|--------|----------------|-------------|---------------|-------|---------------|-----|-----|----|----|------------|
| | | | | | A | B | C | D | H | Level bolt |
| VC-200 | 200 | 0.9 | 70 / 60 | Green | 184 | 157 | 127 | 14 | 79 | M12 |
| VC-300 | 300 | 1.0 | 80 / 70 | Blue | | | | | | |
| VC-500 | 500 | 1.0 | 85 / 75 | Red | | | | | | |

(NOTE) The mentioned size and scale can be altered to improve the quality performance and capacity of the product without any notice.

VC Conical Mount (Deflection : 15mm)

VC Test Data

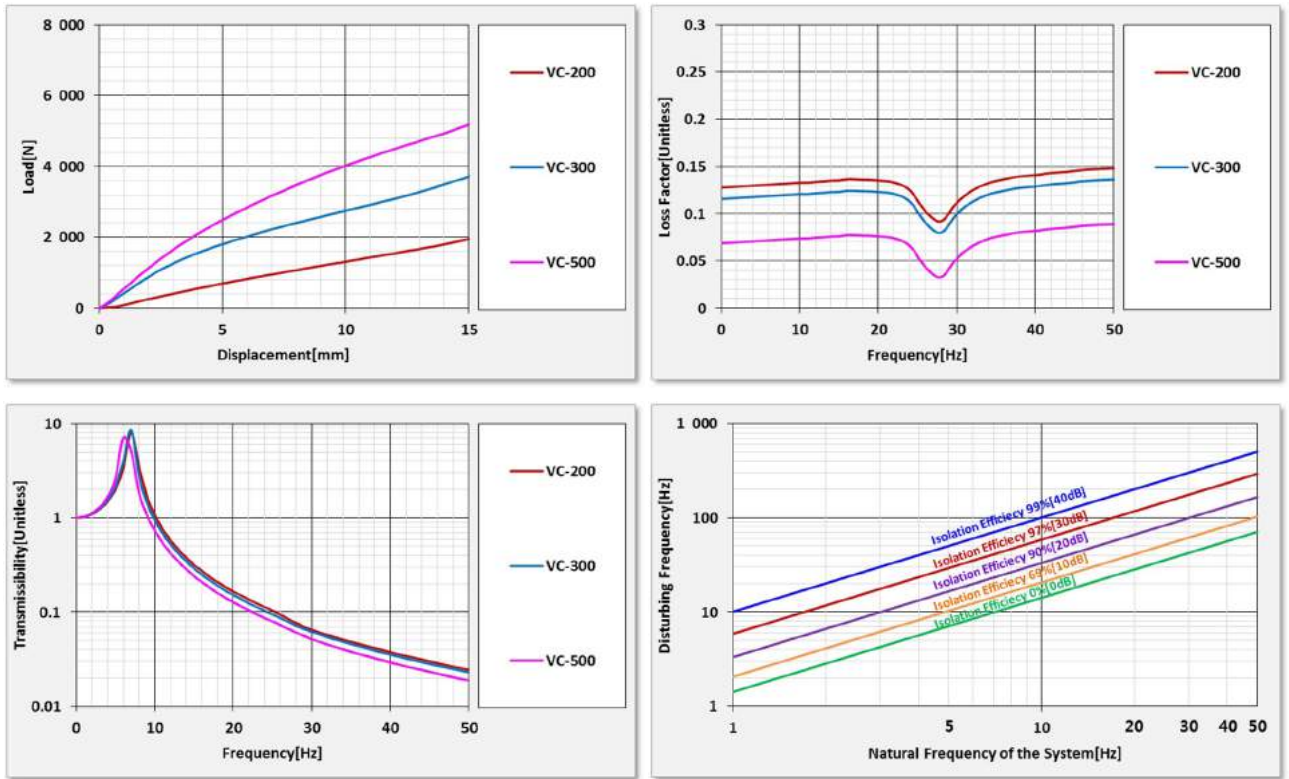

Explanation(Commonness)

1. Vibration Transmissibility(T_r)
Vibration Transmissibility is the amplitude ratio of Output to Input.

$$T_r = \frac{\text{Output Amplitude}}{\text{Input Amplitude}} = \sqrt{\left(\frac{1}{1-\eta^2}\right)^2} \cdot \eta = \frac{\text{Disturbing Frequency of the equipment}}{\text{Natural Frequency of the Isolator (Damping}(c) = 0)}$$

2. Natural Frequency(F_n) of Vibration Isolation System
The mass and spring stiffness dictate a natural frequency of the system.

$$F_n = \frac{1}{2\pi} \sqrt{\frac{k}{m}}$$

3. Isolation Efficiency(E)
Isolation Efficiency in percent transmission is related to Vibration Transmissibility $E = 100(1 - T_r)$

ex) Disturbing Frequency of the equipment=100 Hz,
Natural Frequency of the isolator=10Hz

$$T_r = \sqrt{\left(\frac{1}{1-\eta^2}\right)^2} = \sqrt{\left(\frac{1}{1-\left(\frac{100}{10}\right)^2}\right)^2} = 0.101 \quad E = 100(1 - T_r) = 100(1-0.101)=99(\%)$$

Installation Features

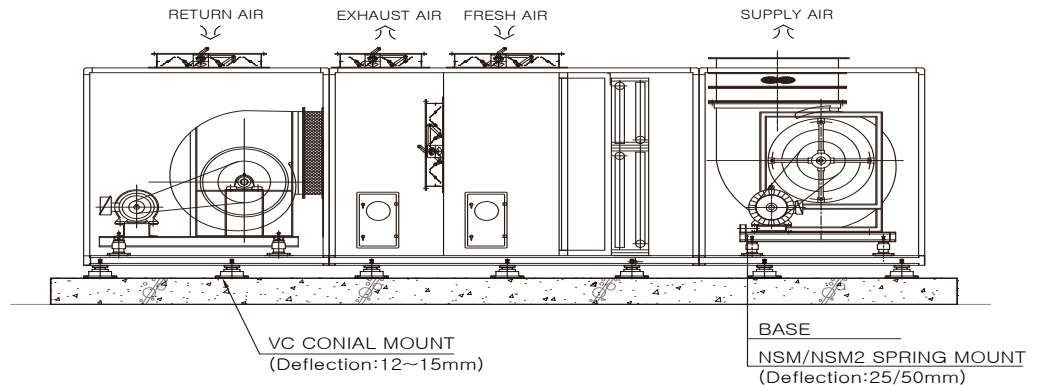

HORIZONTAL AIR CONDITIONER ▶

SRP Spring Rubber Pad (Deflection : 5.5~7mm)

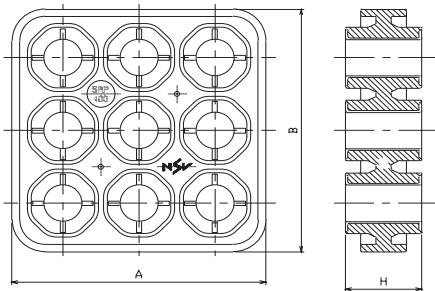
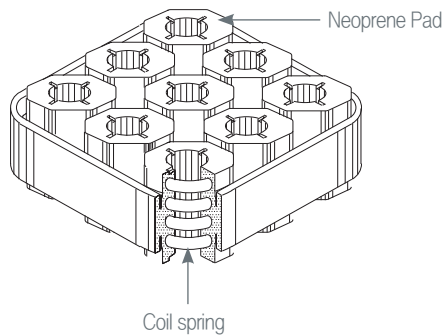

■ Features

It is a highly-efficient product that provides 3-4 times higher vibration isolation efficiency than the conventional rubber pad by using the metal spring's low natural frequency and all of the advantages of anti-vibration rubber, such as multi-axis pavement, high frequency and noise isolation effects. By lowering its center of gravity as low as possible, the load can be evenly distributed on the pad.

■ Usage

- ◆ For facilities and equipment (PUMP, FAN, AHU)
- ◆ For industrial machines (Press, Shearing Machine)
- ◆ For horizontal pipes
- ◆ For vertical pipes Anchor and Guide
- ◆ For all kinds of equipment installed on a solid base

■ Specification

| Category | Metal Spring | Rubber Isolator | Spring Pad |
|--|--------------|-----------------|---------------|
| Natural Frequency(Hz) | 2~10 | 5~100 | 7~9 |
| Multi-axis directional pavement performance | △ | ◎ | ◎ |
| Attenuation performance | X | =Under 0.1 | =0.15~0.25 |
| high frequency blocking capability and soundproof effect | X | ○ | ○ |
| linearity of load characters | ◎ | △ | ◎ |
| uniformity of the product | ◎ | △ | ◎ |
| weight | heavy | medium | medium |
| price | medium | low | low to medium |

■ Dimension & Selection Guide

| Type | Capacity (kgf) | Hardness (HS) | Deflection (mm) | Weight (kg) | Dimension(mm) | | | | |
|----------|----------------|---------------|-----------------|-------------|---------------|------|-----|-----|----|
| | | | | | A | B | H | | |
| SRP-25 | 25 | 40±5 | 5.5 | 0.02 | 57 | 71 | 19 | | |
| SRP-50 | 50 | | | 0.04 | | | | | |
| SRP-100 | 100 | | | 0.1 | | | | | |
| SRP-200 | 200 | | | 0.12 | | | | | |
| SRP-400 | 400 | | | 0.32 | 100 | 100 | 30 | | |
| SRP-600 | 600 | | | 0.33 | | | | | |
| SRP-800 | 800 | | | 0.38 | | | | | |
| SRP-1000 | 1000 | | | 0.84 | | | | | |
| SRP-1200 | 1200 | | | 0.88 | 154 | 118 | 30 | | |
| SRP-1500 | 1500 | | | 0.88 | | | | | |
| SRP-2000 | 2000 | | | 0.86 | | | | | |
| SRP-2500 | 2500 | | | 0.92 | | | | | |
| SRP-3000 | 3000 | | | | 7 | 0.96 | 190 | 118 | 30 |

(NOTE) The mentioned size and scale can be altered to improve the quality performance and capacity of the product without any notice.

SRP Spring Rubber Pad (Deflection : 5.5~7mm)

SRP Test Data

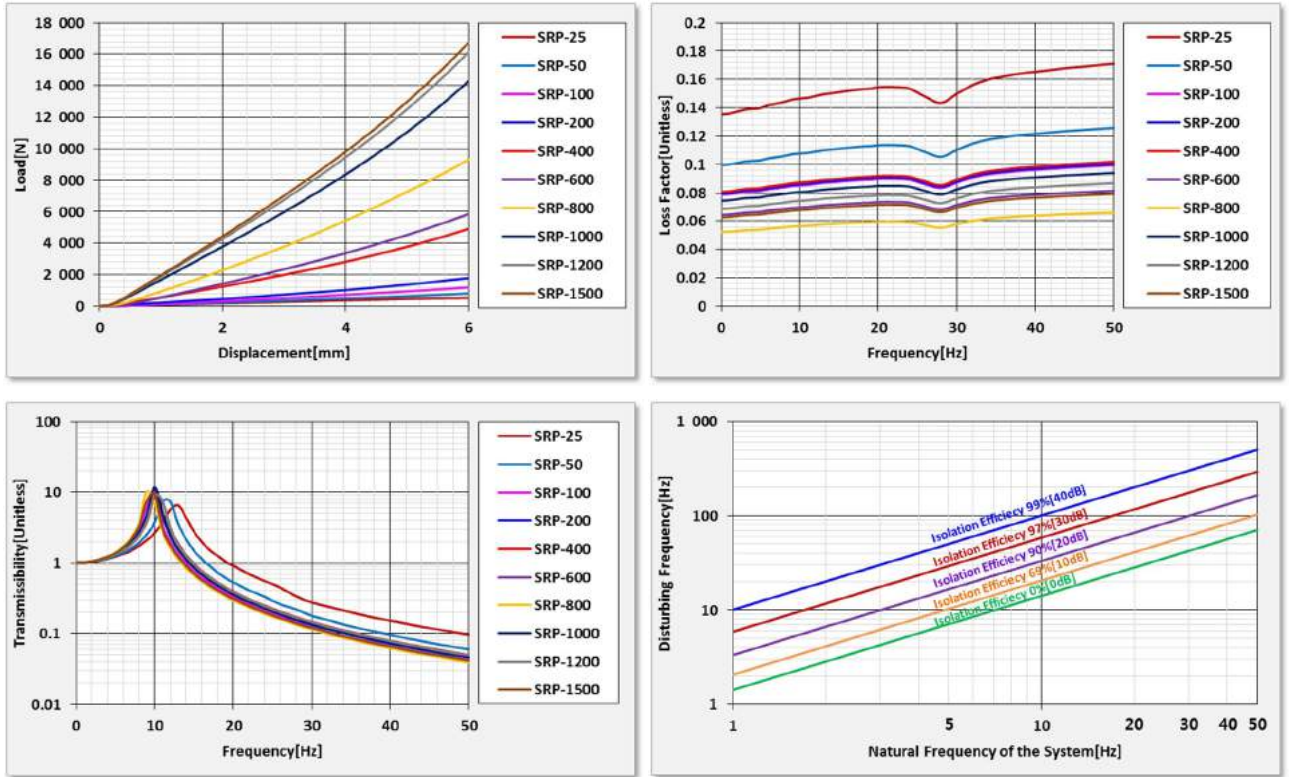

Explanation(Commonness)

1. Vibration Transmissibility(T_r)

Vibration Transmissibility is the amplitude ratio of Output to Input.

$$T_r = \frac{\text{Output Amplitude}}{\text{Input Amplitude}} = \sqrt{\left(\frac{1}{1-\eta^2}\right)^2}, \eta = \frac{\text{Disturbing Frequency of the equipment}}{\text{Natural Frequency of the Isolator (Damping } c = 0)}$$

2. Natural Frequency(F_n) of Vibration Isolation System

The mass and spring stiffness dictate a natural frequency of the system.

$$F_n = \frac{1}{2\pi} \sqrt{\frac{k}{m}}$$

3. Isolation Efficiency(E)

Isolation Efficiency in percent transmission is related to Vibration Transmissibility $E = 100(1 - T_r)$

ex) Disturbing Frequency of the equipment=100 Hz,

Natural Frequency of the isolator=10Hz

$$T_r = \sqrt{\left(\frac{1}{1-\eta^2}\right)^2} = \sqrt{\left(\frac{1}{1-\left(\frac{100}{10}\right)^2}\right)^2} = 0.101 \quad E = 100(1 - T_r) = 100(1-0.101)=99(\%)$$

Installation Features

OUTDOOR UNIT OF AIR CONDITIONAL ▶

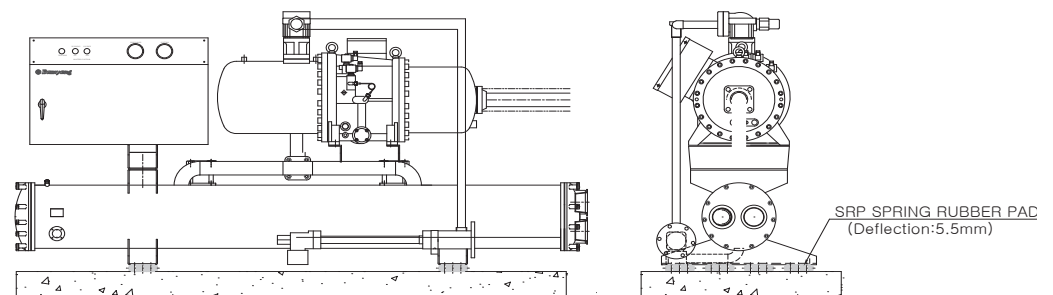

SRM Spring Rubber Mount (Deflection : 5.5mm)

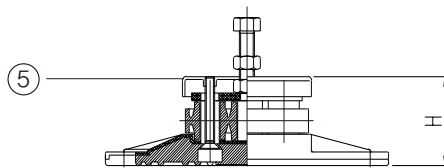
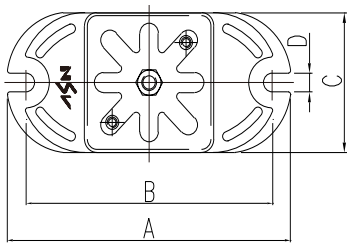
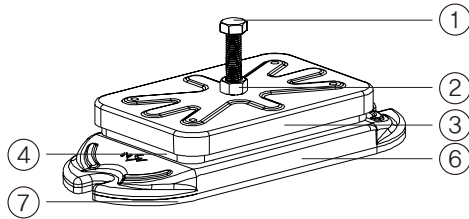

■ Features

It is an improved, mount version of SRP type spring rubber pad taking advantage of anti-vibration rubber and metal spring. SRM type enables control of the level to reduce horizontal deflection. Moreover, its external housing is made of stainless steel to prevent corrosion when installed outside.

■ Usage

- ◆ For facilities and equipment (for example, PUMP, AHU and FAN)
- ◆ For industrial equipment (including Press, Shearing Machine and Lathe)
- ◆ For all kinds of equipment installed on a solid base
- ◆ For vertical and horizontal pipes

■ Specification

| No. | Name of Components | Material | Standard |
|-----|--------------------|----------|-----------|
| 1 | Level Bolt | SS400 | KS B 1002 |
| 2 | Nut | SS400 | KS B 1012 |
| 3 | Upper Housing | STS304 | KS D 3698 |
| 4 | SRP PAD | SUP9 | KS B 2402 |
| | | CR | KS M 6617 |
| 5 | Middle Plate | SS400 | KS D 3503 |
| 6 | Lower Housing | STS304 | KS D 3698 |
| 7 | Lower Non Skid Pad | CR | KS M 6617 |

■ Dimension & Selection Guide

| Type | Capacity (kgf) | Deflection (mm) | Weight (kg) | Dimension(mm) | | | | | |
|----------|----------------|-----------------|-------------|---------------|-----|-----|----|----|------------|
| | | | | A | B | C | D | H | Level Bolt |
| SRM-100 | 100 | 5.5 | 0.8 | 147 | 116 | 80 | 12 | 65 | M10X60 |
| SRM-200 | 200 | | 0.81 | | | | | | |
| SRM-400 | 400 | | 1.71 | | | | | | |
| SRM-600 | 600 | | 1.71 | 226 | 200 | 104 | 12 | 70 | M12X65 |
| SRM-800 | 800 | | 1.76 | | | | | | |
| SRM-1000 | 1000 | | 3.7 | | | | | | |
| SRM-1200 | 1200 | | 3.74 | 309 | 279 | 130 | 12 | 70 | M12X65 |
| SRM-1500 | 1500 | | 3.7 | | | | | | |
| SRM-2000 | 2000 | 3.74 | | | | | | | |

(NOTE) The mentioned size and scale can be altered to improve the quality performance and capacity of the product without any notice.

■ Installation Features



SRA Spring Rubber Mount (Deflection : 6~12mm)

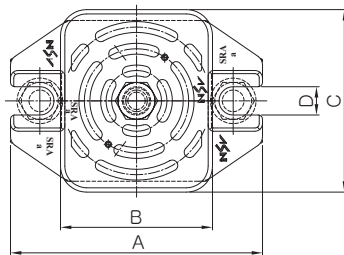
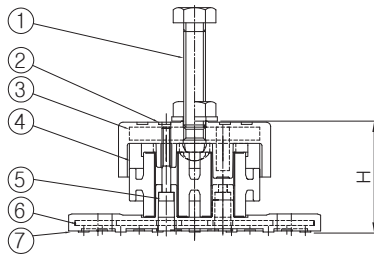
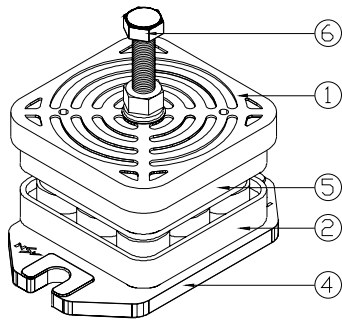

■ Features

SRA mount is an improved version of SRM spring rubber mount with upgraded shock and vibration control effects. With SRP spring rubber pad, it facilitates control of the level and moreover, this pad can be installed in 2 layers to increase efficiency. It is designed to insert a reinforcing plate in-between in order to remove insecurity when displacement increases and to bear the load in a stable manner while preventing separation. On the top and bottom of the SRA mount, bumpy neoprene housing with reinforcing material inside is mounted to prevent slipping from the equipment and to shut out structure-borne noise.

■ Usage

- ◆ For facilities and equipment (for example, pump, AHU and fan)
- ◆ For vertical/horizontal pipes and ducts
- ◆ For industrial equipment
- ◆ For machines that generate vibration in horizontal and vertical directions

■ Specification

| No. | Name of Components | Material | Standard |
|-----|--------------------|----------|-----------|
| 1 | Upper Housing | CR | KS M 6617 |
| 2 | SRP PAD | CR+SUP9 | KS M 6617 |
| 3 | Bolt | SS400 | KS B 1003 |
| 4 | Lower Housing | CR | KS M 6617 |
| 5 | Middle plate | SS400 | KS D 3503 |
| 6 | Level Bolt | S400 | KS B 1002 |

■ Dimension & Selection Guide

| Model | Type | Capacity (kgf) | Deflection (mm) | Weight (kg) | Dimension(mm) | | | | | |
|-------|-----------|----------------|-----------------|-------------|---------------|----|----|----|----|------------|
| | | | | | A | B | C | D | H | Level Bolt |
| SRA | SRA-100 | 100 | 6.0 | 0.64 | 114 | 89 | 84 | 13 | 47 | M10X65L |
| | SRA-200 | 200 | | 0.66 | | | | | | M10X65L |
| | SRA-400 | 400 | | 1.86 | | | | | | M12X70L |
| | SRA-600 | 600 | | 1.88 | | | | | | M12X70L |
| | SRA-800 | 800 | | 1.84 | | | | | | M12X70L |
| SRA-2 | SRA-2-100 | 100 | 12.0 | 0.82 | 114 | 89 | 84 | 13 | 81 | M10X65L |
| | SRA-2-200 | 200 | | 0.86 | | | | | | M10X65L |
| | SRA-2-400 | 400 | | 2.50 | | | | | | M12X70L |
| | SRA-2-600 | 600 | | 2.52 | | | | | | M12X70L |
| | SRA-2-800 | 800 | | 2.60 | | | | | | M12X70L |

(NOTE) The mentioned size and scale can be altered to improve the quality performance and capacity of the product without any notice.

SRH-U Spring Rubber Mount (Deflection : 5.5mm)

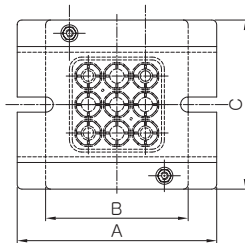
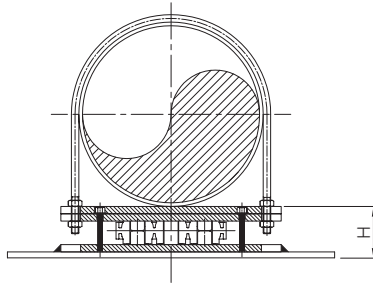
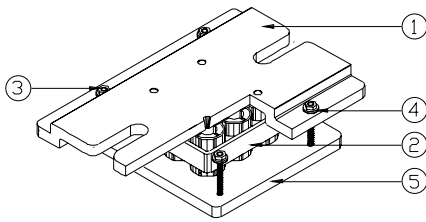

■ Features

It is an upgraded mount designed to control vibration from horizontal pipes using SRP type spring rubber pad with advantages of anti-vibration rubber and metal spring. SRH type is installed on top of steel structure individually or together to better absorb vibration from pipes. Plus, U-bolt slot hole is on steel plate of top and bottom housings, which facilitates installation and prevents pipes from getting out of their original location.

■ Usage

For horizontal pipes

■ Specification

| No. | Name of Components | Material | Standard |
|-----|--------------------|----------|-----------|
| 1 | Upper Housing | SS400 | KS D 3503 |
| 2 | SRP PAD | SUP9 | KS B 2402 |
| | | CR | KS M 6617 |
| 3 | Bolt & Nut | SS400 | KS B 1002 |
| 4 | Guide Rubber | CR | KS M 6617 |
| 5 | Base Plate | SS400 | KS D 3503 |

■ Dimension & Selection Guide

| Pipe Diameter | SRP | A | B | C | H |
|---------------|--------------|-----|-----|-----|----|
| φ50 | A(100,200) | 110 | 110 | 86 | 40 |
| φ65 | | 110 | 110 | 86 | 40 |
| φ80 | | 120 | 120 | 74 | 40 |
| φ100 | | 150 | 120 | 74 | 40 |
| φ125 | | 175 | 120 | 74 | 40 |
| φ150 | | 200 | 120 | 74 | 40 |
| φ150 | B(400~800) | 200 | 150 | 122 | 42 |
| φ200 | B(400~800) | 270 | 210 | 122 | 42 |
| φ250 | B(400~800) | 320 | 260 | 122 | 42 |
| φ250 | C(1000~2000) | 320 | 260 | 140 | 42 |
| φ300 | B(400~800) | 380 | 300 | 122 | 42 |
| φ300 | C(1000~2000) | 380 | 300 | 140 | 42 |
| φ350 | | 420 | 320 | 140 | 42 |
| φ400 | | 470 | 400 | 140 | 42 |
| φ450 | | 520 | 420 | 140 | 42 |
| φ500 | | 570 | 500 | 140 | 42 |

(NOTE) The mentioned size and scale can be altered to improve the quality performance and capacity of the product without any notice.

SRH-SH Spring Rubber Mount (Deflection : 5.5mm)

■ Features

It Is Used As A Sliding Shoe On The Pipe And Installed Using Pipe Clip & Bolt. The Allowed Range Of Support Spacing For Horizontal Pipe Is From 2.0 M To 5.0 M And, The Model Changes Depending On The Support Spacing.



SRH-A TYPE

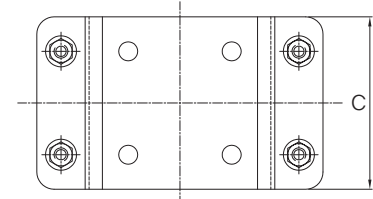
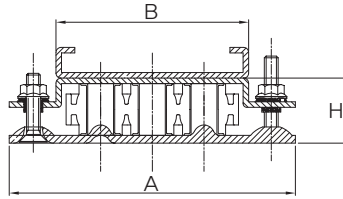

SRH-B TYPE

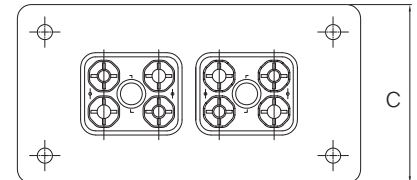
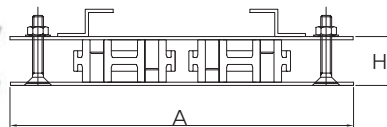

■ SRH-A TYPE Dimension & Selection Guide

| Pipe Diameter | SRP | A | B | C | H |
|---------------|-------------|-----|-----|-----|----|
| φ50 | A(100,200) | 166 | 80 | 100 | 56 |
| φ65 | | | | | |
| φ80 | | | | | |
| φ100 | | | | | |
| φ125 | B(100~800) | 166 | 105 | 100 | |
| φ150 | | | | | |
| φ200 | | | | | |
| φ250 | | | | | |
| φ300 | | | | | |
| φ350 | C(400~2000) | 266 | 156 | 140 | |
| φ400 | | | | | |
| φ450 | | | | | |

(NOTE) The mentioned size and scale can be altered to improve the quality performance and capacity of the product without any notice.

■ SRH-B TYPE Dimension & Selection Guide

| SRP | A | C | H |
|---------------|-----|-----|----|
| 100X2EA | 250 | 150 | 48 |
| 200X2EA | 250 | 150 | 48 |
| 100X2EA | 250 | 150 | 48 |
| 200X2EA | 250 | 150 | 48 |
| 200X2EA | 250 | 150 | 48 |
| 200X2EA | 250 | 150 | 48 |
| 400X2EA | 350 | 150 | 48 |
| 600X2EA | 350 | 150 | 48 |
| 600~800X2EA | 350 | 150 | 48 |
| 1000~1500X2EA | 350 | 200 | 48 |

(NOTE) The mentioned size and scale can be altered to improve the quality performance and capacity of the product without any notice.

VP-1000 Rubber Pad (Deflection : 4-10mm)

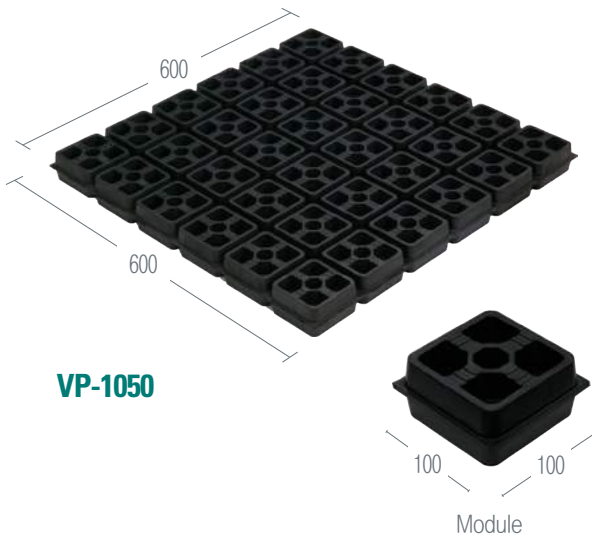
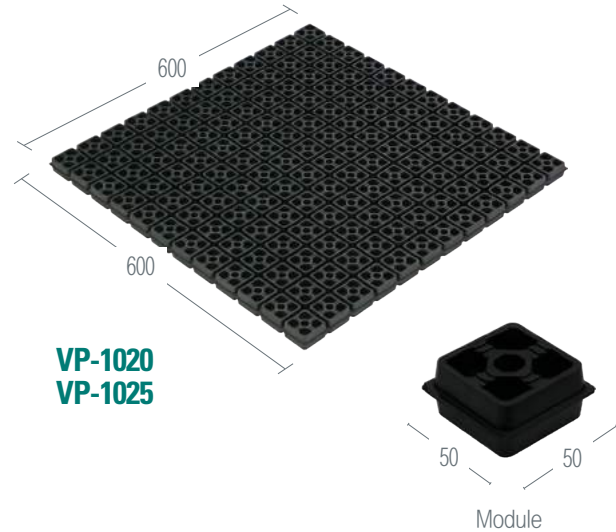
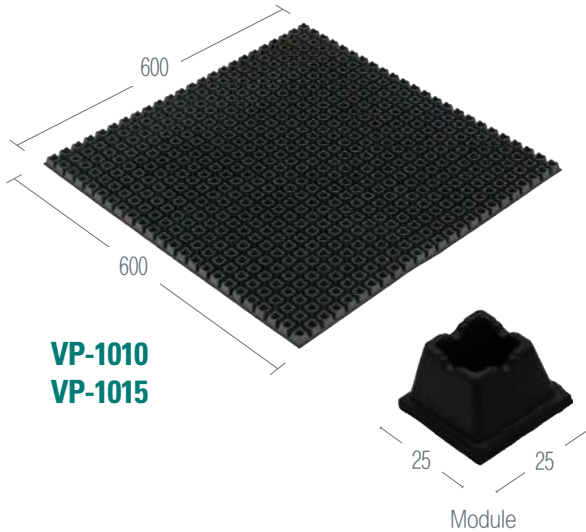

■ Features

VP-1000 type is a vibro-isolation pad made of CR(neoprene) with excellent oil and ozone resistance. An advantage is a wide range of working load due to the projected net area designed calculating working load and statistic displacement separately. Its modular design allows cutting it into small pieces as you want to use.

■ Application

- ◆ In general, to control HF vibration by installing it under the bottom of the machine
- ◆ To damp vibration from generators/air compressors/chillers/air handling units
- ◆ To damp vibration form various kinds of machine installed on the solid base.
- ◆ To prevent transmission of vibration and noise through the structures

■ Dimension & Selection Guide By Loads

| Type | Capacity (kgf) | Deflection (mm) | Hardness (Hs) | Dimension (mm) | | | |
|---------|----------------|-----------------|---------------|----------------|--------|-----------|-------------|
| | | | | width | Length | Thickness | Module Size |
| VP-1010 | 21,600 | 4 | 60±5 | 600 | 600 | 10 | 25 X 25 |
| VP-1015 | 21,600 | 5 | | | | 15 | 25 X 25 |
| VP-1020 | 20,160 | 6 | | | | 20 | 50 X 50 |
| VP-1025 | 20,160 | 7 | | | | 25 | 50 X 50 |
| VP-1050 | 24,800 | 10 | | | | 50 | 100 X 100 |

VP-2000 Rubber Pad (Deflection : 3-6mm)



■ Features

VP-2000 type is a vibration isolation pad made of CR(neoprene) with excellent oil resistance and ozone resistance. It has the excellent vibration isolation performance from serrated patterns engaged from the top and bottom surface making no horizontal shift and having enough deflection. Since the ability to support a load is proportional to the surface area, it can be used in various ways. Especially, it is an optimum vibro-isolating pad for structure borne sound. It can be designed into layered structure. With the large value of corresponding static displacement to the same load, the natural frequency of the lower system is variable.

■ Application

- ◆ In general, to control HF vibration by installing it under the bottom of the machine
- ◆ To damp vibration from generators/air compressors/chillers/air handling units
- ◆ To damp vibration form various kinds of machine installed on the solid base.
- ◆ To prevent transmission of vibration and noise through the structures

■ Dimension & Selection Guide

| Type | Capacity(kgf) | Deflection(mm) | Hardness(Hs) | Dimension(mm) | | |
|---------|---------------|----------------|--------------|---------------|--------|-----------|
| | | | | width | Length | Thickness |
| VP-2008 | 16,000 | 3 | 60±5 | 600 | 600 | 8 |
| VP-2010 | 16,400 | 4 | | | | 10 |
| VP-2012 | 16,800 | 4 | | | | 12 |
| VP-2015 | 17,600 | 5 | | | | 15 |
| VP-2020 | 18,000 | 6 | | | | 20 |

(NOTE) The mentioned size and scale can be altered to improve the quality performance and capacity of the product without any notice.

VP-3000 Rubber Pad (Deflection : 6/12mm)



■ Features

Its cover made of CR(neoprene) with excellent oil and ozone resistance and the HD mat inside with outstanding damping characteristics dramatically improve damping performance. Its modular design allows cutting it into small pieces as you want to use.

■ Usage

- ◆ In general, to control HF vibration by installing it under the bottom of the machine
- ◆ To damp vibration from generators/air compressors/chillers/air handling units
- ◆ To damp vibration form various kinds of machine installed on the solid base
- ◆ To prevent transmission of vibration and noise through the structures

■ Dimension & Selection Guide

| Type | Capacity(kgf) | Deflection(mm) | Weight(kg) | Dimension(mm) | | | |
|---------|---------------|----------------|------------|---------------|--------|-----------|-------------|
| | | | | width | Length | Thickness | Module Size |
| VP-3025 | 8,000 | 6 | 60±5 | 600 | 600 | 25 | 100X50 |
| VP-3050 | 8,000 | 12 | | | | 50 | |

(NOTE) The mentioned size and scale can be altered to improve the quality performance and capacity of the product without any notice.

VP-1000/VP-2000 Rubber Pad

■ VP-1000 Test Data

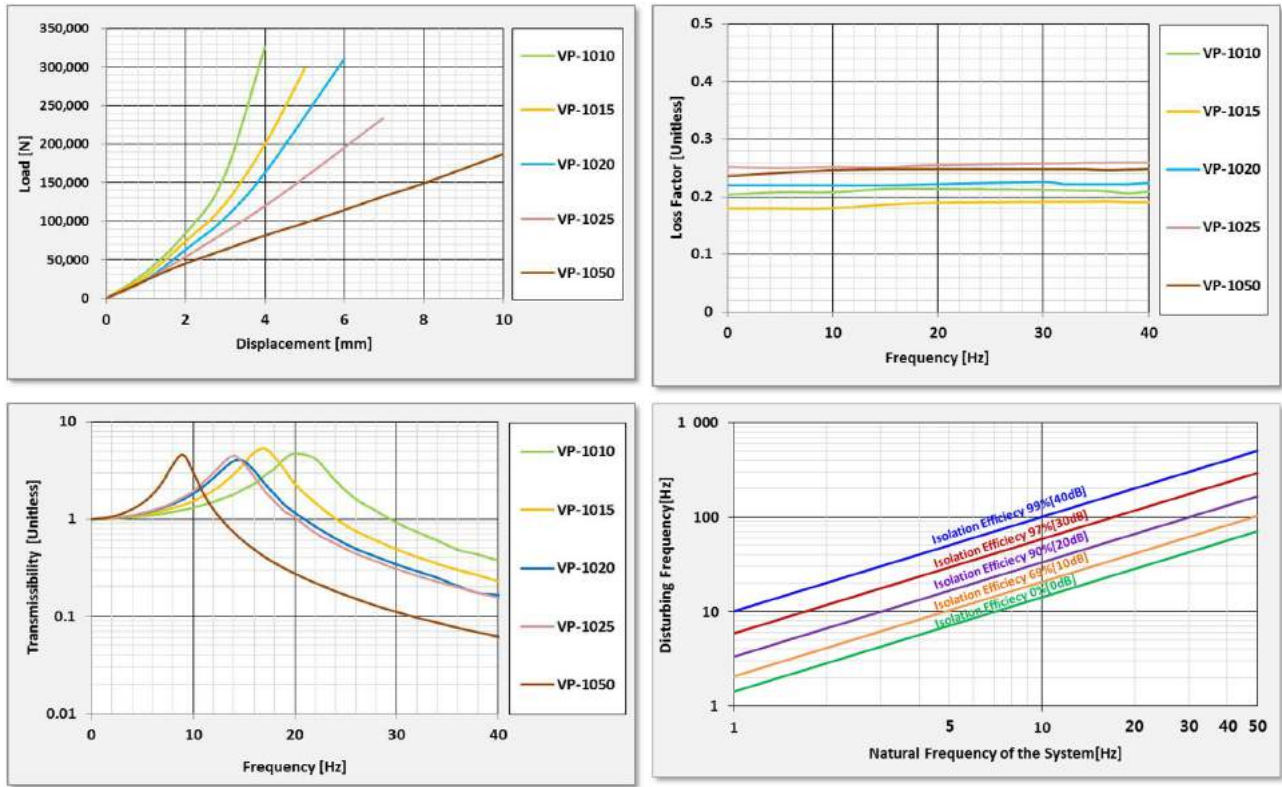

■ VP-2000 Test Data

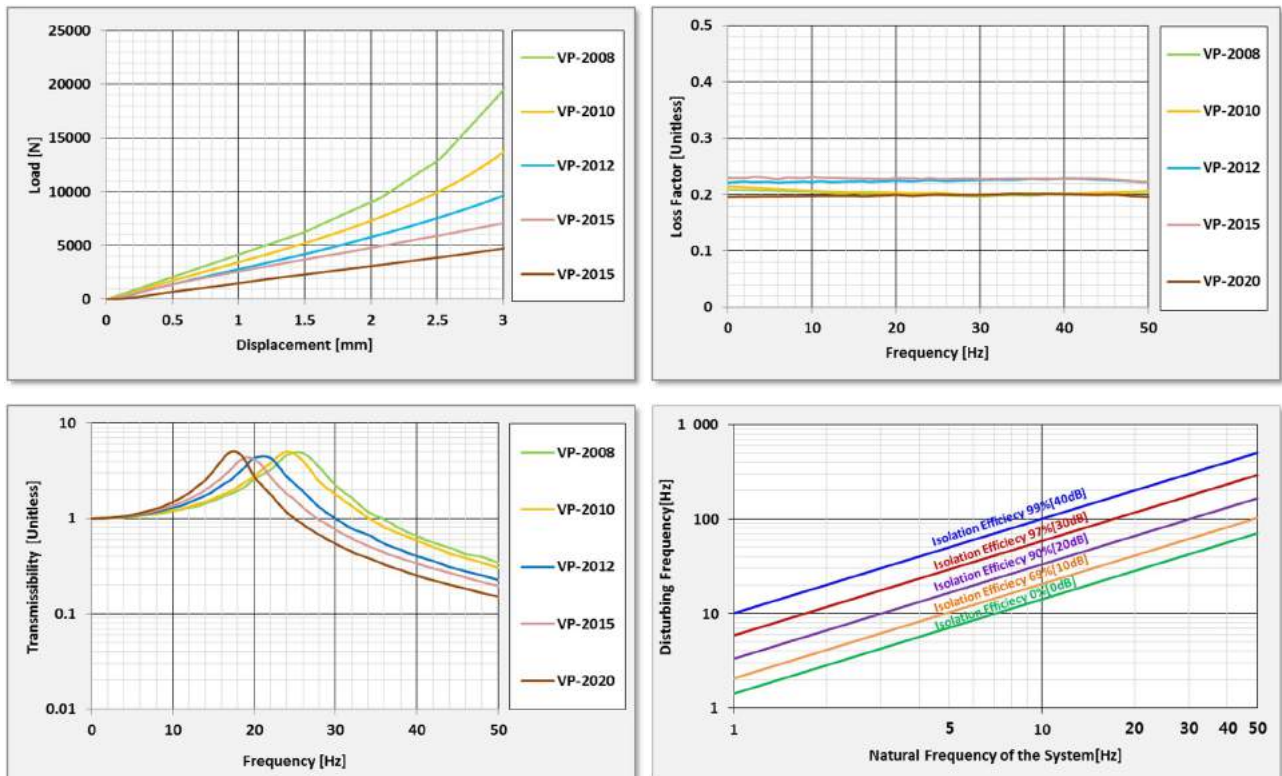

IB Inertia Base Series

■ Features

IB (Inertia Base) is designed to shut out vibration that occurs while the pump is running, and at the same time, minimize the dynamic deflection resulting from the dynamic force generated when the load rapidly changes, using the weight of concrete. It consists of the base (┐-angle) with C-channel for an easier assembling of the base, pump and motor, bracket for mount and reinforcing bottom plate. The height (H) of Inertia Base is at least 150 mm, and it differs depending on horse power of the motor.

■ IB-150 series For Single-Suction Pumps (Single, Multi-Stage Volute, etc.)

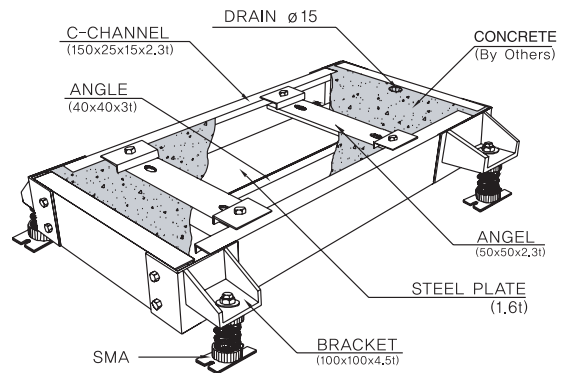
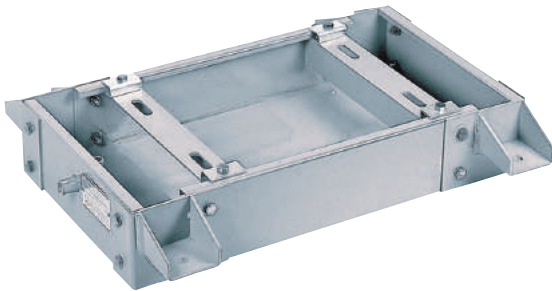

■ IB-200 series For Double-Suction Pumps

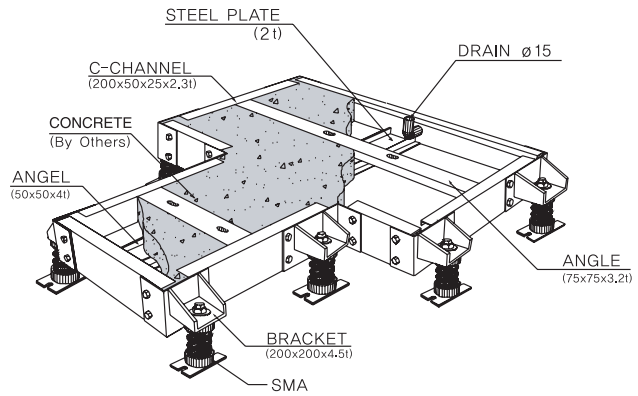
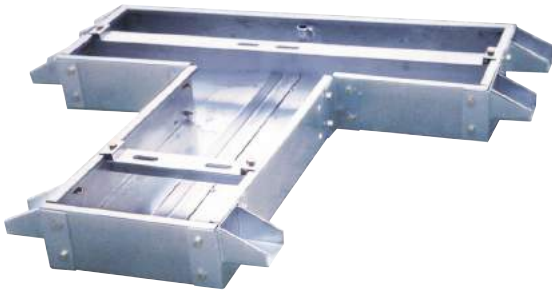

■ Installation Features



SB Elasticity Structural Base

■ Features

GHP/EHP cools and heats the air through the circulation of refrigerant's heat pump cycle and it generates vibration when the compressor runs. In the case that several GHP/EHP are installed in a group, they could generate superposed oscillation, and as a result, cause damage. To prevent this, vibration isolators with a built-in stand are mounted on the equipment. This stand is double-structured with a stopper inside to ensure the structural stability against external pressure.

■ SB-H

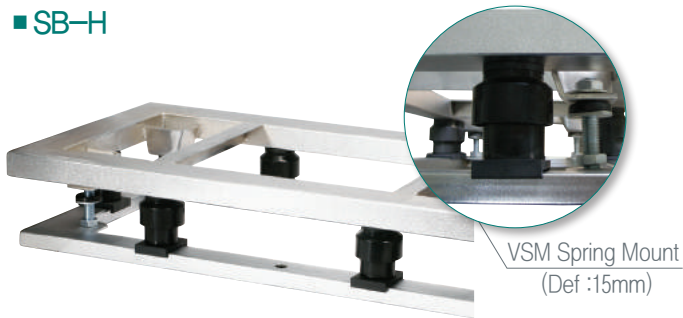

■ SB-R

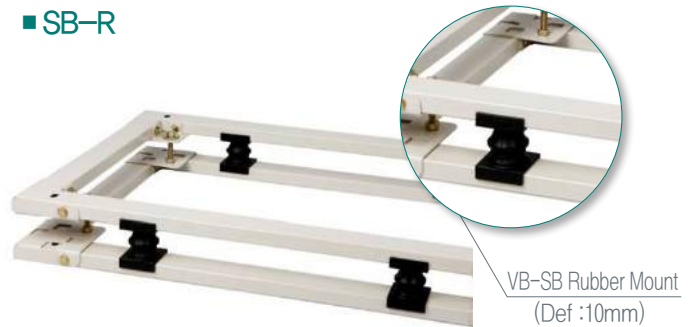

■ SB-S



■ SB Installation Details Drawing

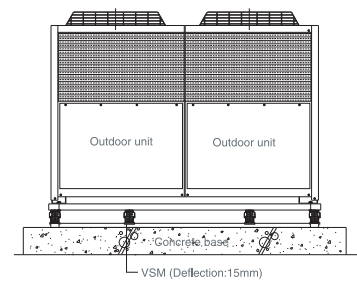
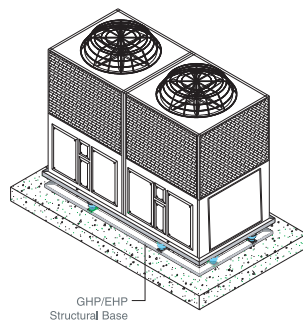

■ Installation Features



NFC Flexible Connector

NFC10S

※ The model name of NFC-S product has changed to NFC10S



Screw Type

NFC10

※ The model name of NFC-1 product has changed to NFC10



1Ball Type

NFC20

※ The model name of NFC-2 product has changed to NFC20



2Ball Type

■ Features

The flexible connector is mounted between pipes to absorb the stress resulting from the expansion and contraction of the pipe line and shut out the vibration caused by flow of fluid and vibration transferred from equipment. It also maintains an allowable connection error of pipe line, and by doing so, gives flexibility to the whole system.

- (a) Operating temperature: $-20^{\circ}\text{C} \sim +80^{\circ}\text{C}$
- (b) Operating pressure: for 10kgf/cm^2 and 20kgf/cm^2
- (c) Materials: NEOPRENE, EPDM

■ The composition of products

It is made of nylon tire cord, special synthetic rubber (NEOPRENE, EPDM) and piano steel wire. It has a stiffening ring between balls to avoid excessive expansion by internal pressure.

■ Product Special Feature

- (a) Excellent resistance against pressure. This product consist of synthetic rubber, nylon tire cord Fabric and piano steel wire. The destruction pressure is Within 55kgf/cm^2 and usage pressure is up to maximum 30kgf/cm^2 .
- (b) Large allowance of concentricity error. Due to Two arch structure, it has good flexibility to all direction. As having large amount of concentricity error allowance, this product protects equipment of pipe line from vibration or other shock damage.
- (c) Large allowance of banding angle and elasticity. This product has allowable banding angle and elasticity Enough to stand pipe-line movement owing to outside Impact.
- (d) Grate anti-vibration and anti-noise effect.
- (e) Good Water resistance, Thermal endurance, Weatherability and Chemical resistance.

■ Maximum Operating Pressure And Temperature

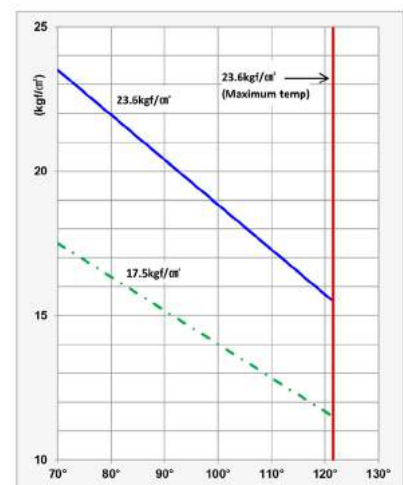

NFC Flexible Connector

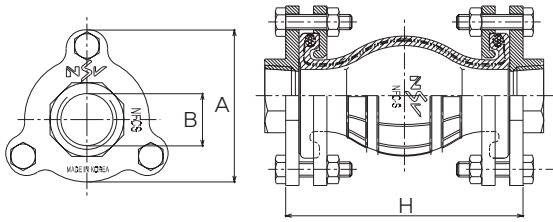

NFC10S (Screw Type)

Dimension & Selection Guide

| Type | Flange Dimension(mm) | | |
|-----------|----------------------|-----|-----|
| | A | B | H |
| NFC10S-25 | 81 | 25A | 125 |
| NFC10S-32 | 90 | 32A | 143 |

(NOTE) The mentioned size and scale can be altered to improve the quality performance and capacity of the product without any notice.

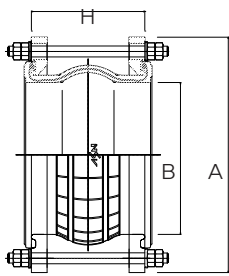

NFC10 (1Ball Type)

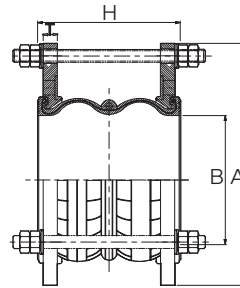

NFC20 (2Ball Type)

Dimension & Selection Guide

| Type | Flange Dimension(mm) | | | | Dimension(mm) | | | | Qty of Control Rod | |
|---------------|----------------------|------|-----------|-----------|---------------|--------|---------------|-------|--------------------|-----|
| | A | B | H (1Ball) | H (2Ball) | Compression | Height | Concentricity | Curve | 10K | 20K |
| NFC10(20)-32 | 205 | 32A | 125 | 150 | 38 | 13 | 16 | 30° | 2 | 2 |
| NFC10(20)-40 | 205 | 40A | 125 | 150 | | 13 | 16 | 30° | | |
| NFC10(20)-50 | 220 | 50A | 125 | 150 | | 13 | 16 | 30° | | |
| NFC10(20)-65 | 240 | 65A | 125 | 160 | | 13 | 22 | 30° | | |
| NFC10(20)-80 | 252 | 80A | 125 | 160 | | 19 | 22 | 30° | 3 | 3 |
| NFC10(20)-100 | 285 | 100A | 150 | 180 | | 19 | 22 | 29° | | |
| NFC10(20)-125 | 336 | 125A | 150 | 180 | | 19 | 22 | 24° | 4 | 4 |
| NFC10(20)-150 | 376 | 150A | 150 | 180 | | 19 | 22 | 20° | | |
| NFC10(20)-200 | 380 | 200A | 175 | 220 | | 19 | 22 | 15° | | |
| NFC10(20)-250 | 448 | 250A | 175 | 220 | | 22 | 32 | 30° | | |
| NFC10(20)-300 | 495 | 300A | 200 | 220 | | 22 | 32 | 30° | 4 | 4 |
| NFC10(20)-350 | 600 | 375A | 200 | 250 | | 22 | 32 | 30° | | |
| NFC10(20)-400 | 560 | 383A | 250 | 250 | | 22 | 32 | 29° | | |

(NOTE) The mentioned size and scale can be altered to improve the quality performance and capacity of the product without any notice.



OVER 450A

Anchoring and Control rods of pipe line

When use a Flexible connector, pipe line should expand or contract by only one direction anchor rods for Preventing flexible connector cracking. Or installing control rods on the flange of flexible connector protect pipe Line from damage owing to over-expansion or over-contraction.

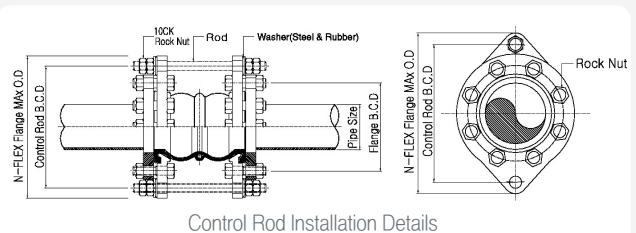

Control Rod Installation Details

NV10 Flexible Connector

※ The model name of NVC product has changed to NV10



■ Features

It is installed on the intake/outlet of the pump to give flexibility, and at the same time, somewhat reduce vibration. Because it uses a multi-layered bellow, it has a small spring reaction. Plus, it transfers no vibration through brad as it does not use tie rod. It is made of stainless steel, which ensures a long lifespan and stable pipe system even at a high temperature.

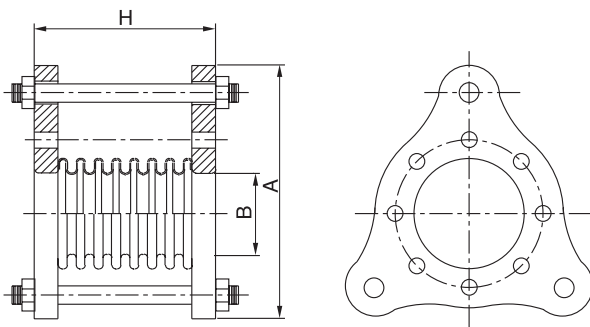

■ Specification

- ◆ Applied fluid : cool & hot water, steam, liquid
- ◆ Maximum operating pressure : 10kgf/cm²
- ◆ Maximum operating temperature : 220°C
- ◆ Connecting method : KS 10K FF FRANGE
- ◆ Resisting pressure test : 15kgF/cm² in water
- ◆ Material : BLOWS : STS, FRANGE : SS

■ Dimension & Selection Guide

| Load(TON) | Flange Dimension(mm) | | | Dimension(mm) | | |
|--------------|----------------------|-----|-----|---------------|-----------|---------------|
| | A | B | H | Pressure | Expansion | Concentricity |
| NV10-10k-32 | 205 | 32 | 80 | 12 | 3 | 3 |
| NV10-10k-40 | 205 | 40 | 80 | | | |
| NV10-10k-50 | 220 | 50 | 115 | | | |
| NV10-10k-65 | 240 | 65 | 120 | | | |
| NV10-10k-80 | 252 | 80 | 120 | | | |
| NV10-10k-100 | 285 | 100 | 125 | | | |
| NV10-10k-125 | 336 | 125 | 130 | | | |
| NV10-10k-150 | 376 | 150 | 140 | | | |
| NV10-10k-200 | 380 | 200 | 150 | | | |
| NV10-10k-250 | 448 | 250 | 200 | | | |
| NV10-10k-300 | 495 | 300 | 200 | | | |
| NV10-10k-350 | 600 | 375 | 200 | | | |
| NV10-10k-400 | 560 | 383 | 200 | | | |
| NV10-20k-32 | 205 | 32 | 85 | | | |
| NV10-20k-40 | 205 | 40 | 85 | | | |
| NV10-20k-50 | 220 | 50 | 119 | | | |
| NV10-20k-65 | 240 | 65 | 128 | | | |
| NV10-20k-80 | 252 | 80 | 132 | | | |
| NV10-20k-100 | 285 | 100 | 141 | | | |
| NV10-20k-125 | 336 | 125 | 144 | | | |
| NV10-20k-150 | 376 | 150 | 158 | | | |
| NV10-20k-200 | 380 | 200 | 172 | | | |
| NV10-20k-250 | 448 | 250 | 218 | | | |
| NV10-20k-300 | 495 | 300 | 222 | | | |
| NV10-20k-350 | 600 | 375 | 230 | | | |
| NV10-20k-400 | 560 | 383 | 236 | | | |

(NOTE) The mentioned size and scale can be altered to improve the quality performance and capacity of the product without any notice.

VD60 Spring Damper Mount

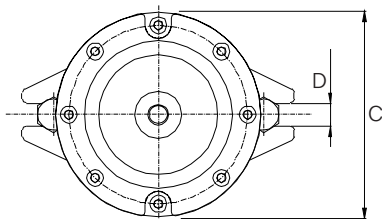
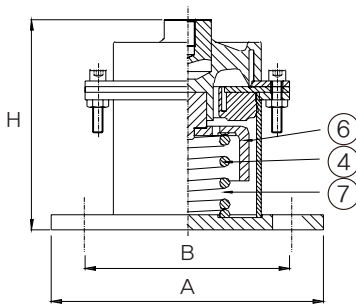
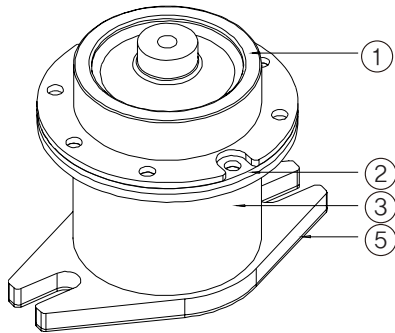

■ Features

It is a solid-bottom mount with the combined features of oil-filled damper, spring and rubber and it is very effective against shock power and periodic vibration. It first converts impulsive vibration into frictional heat energy using oil and then, dissipates periodic vibration using rubber and the spring. The rubber on top is a CR (neoprene)-type synthetic rubber having excellent oil and ozone resistant properties. Because the spring gains a static deflection after assembly, it can maintain a low-natural frequency, less than 5Hz.

■ Usage

- ◆ For high-efficient vibration control of cooling towers
- ◆ For high-efficient vibration control of heavy equipment (semiconductor production line)
- ◆ For equipment generating large impulsive vibration
- ◆ For equipment that is sensitive to surrounding vibration

■ Specification

| No. | Name of Components | Material | Standard |
|-----|--------------------|----------|-----------------------|
| 1 | Upper Cap | CR & GC | KS M 6617 / KS D 4301 |
| 2 | Middle Cap | CR & GC | KS M 6617 / KS D 4301 |
| 3 | Lower Cap | SS400 | KS D 3503 |
| 4 | Coil Spring | SUP9 | KS B 2402 |
| | | HSW3 | KS B 2403 |
| 5 | Non Skid Pad | CR & GC | KS M 6617 |
| 6 | Inner Damper | GC | KS D 4301 |
| 7 | Damper Oil | — | FLUID OIL |

■ Dimension & Selection Guide

| Type | Capacity (kgf) | Dimension(mm) | | | | | |
|-----------|----------------|---------------|-----|-----|----|-----|------------|
| | | A | B | C | D | H | Level Bolt |
| VD60-500 | 500 | 160 | 149 | 184 | 18 | 124 | M12 |
| VD60-1000 | 1000 | 197 | 220 | 270 | 22 | 212 | M20 |
| VD60-1500 | 1500 | 197 | 220 | 270 | 22 | 212 | M20 |
| VD60-2000 | 2000 | 197 | 220 | 270 | 22 | 212 | M20 |

(NOTE) The mentioned size and scale can be altered to improve the quality performance and capacity of the product without any notice.

VAM10 Air Mount (Airpressure : 1.5~6kg/mm)

※ The model name of VAM product has changed to VWM10

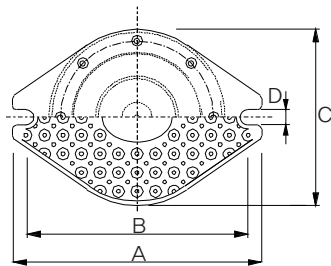
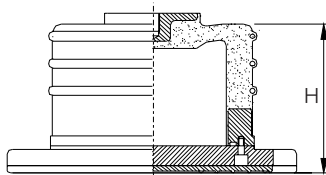
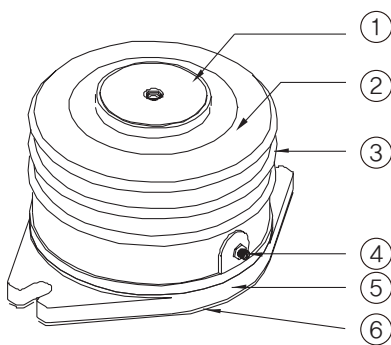

■ Features

An air spring mount is a highly-efficient mount offering features of acyuator as well as an isolator like a coil spring and anti-vibration pad. It can maintain constant vibration isolation efficiency and lower the system's natural frequency down to 2.5~5Hz. Plus, its height can be controlled through the control of internal air pressure and installed in a lower position than the conventional coil spring mount. It allows for a quite, noiseless operation, as it has a structure that does not transfer noise.

■ Usage

- ◆ For vacuum pumps and air compressors
- ◆ For optical measurement equipment and high-precision, semi-conductor manufacturing equipment
- ◆ For a power generator high-speed press
- ◆ For HVAC equipment and industrial machines

■ Specification

| No. | Name of Components | Material | Standard |
|-----|--------------------|----------|-----------|
| 1 | Upper Housing | AL | KS D 2331 |
| 2 | Body | NBR | KS M 6642 |
| 3 | Reinforcing Ring | SS400 | KS D 3503 |
| 4 | Air Valve | BRASS | — |
| 5 | Lower Housing | AL | KS D 2331 |
| 6 | Non Skid Pad | CR | KS M 6617 |

■ Dimension & Selection Guide

| Type | Capacity(kgf) | | Design Pressure (kg/cm ²) | Dimension(mm) | | | | | |
|------------|---------------|------|---------------------------------------|---------------|-----|-----|----|----|------------|
| | Min. | Max. | | A | B | C | D | H | Level Bolt |
| VAM10-150 | 50 | 150 | 1.5~5.0 | 150 | 130 | 105 | 11 | 67 | M12 |
| VAM10-300 | 75 | 300 | 1.5~6.0 | 180 | 160 | 124 | 13 | 93 | M12 |
| VAM10-600 | 150 | 600 | 1.5~6.0 | 250 | 230 | 172 | 13 | 93 | M12 |
| VAM10-1200 | 300 | 1200 | 1.5~6.0 | 350 | 330 | 246 | 13 | 93 | M16 |
| VAM10-2400 | 1250 | 2400 | 1.5~6.0 | 480 | 460 | 340 | 14 | 95 | M20 |

(NOTE) The mentioned size and scale can be altered to improve the quality performance and capacity of the product without any notice.

VAM20 Pneumatic Leveling Isolator

※ The model name of VAD product has changed to VVM20

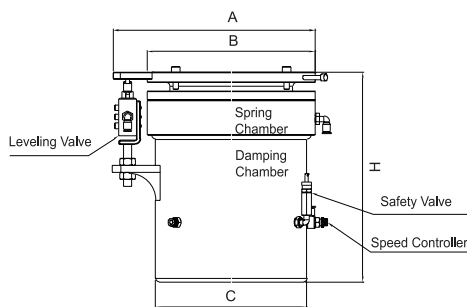

■ Features

It is used to control the vibration of high-precision inspection and measurement equipment. Because it has a low natural frequency less than 2 Hz and causes no surging, it can provide excellent vibration isolation performance. The double diaphragm can also be used to lower its natural frequency. The leveling valve performs automatic leveling while the orifice connecting spring chamber and damping chamber offer a high attenuation of fluid and the speed controller helps control the attenuation ratio. In addition, the piston and viscous oil can help reduce attenuation to be even lower.

■ Usage

- ◆ High-precision measurement equipment, electron microscope and 3D coordinate measuring machine
- ◆ High-precision manufacturing machine and high-precision optical tester
- ◆ Environmental measurement equipment and high-precision calibration instrument
- ◆ High-precision vibration proofing foundation

■ Dimension & Selection Guide

| Type | Capacity (kgf) | Dimension(mm) | | | |
|-------------|----------------|---------------|-----|-----|-----|
| | | A | B | C | H |
| VAM20-300 | 300 | 170 | 120 | 120 | 160 |
| VAM20-800 | 800 | 220 | 170 | 150 | 220 |
| VAM20-1500 | 1500 | 290 | 240 | 220 | 300 |
| VAM20-3000 | 3000 | 350 | 300 | 270 | 300 |
| VAM20-5000 | 5000 | 430 | 380 | 350 | 300 |
| VAM20-10000 | 10000 | 550 | 500 | 460 | 300 |
| VAM20-20000 | 20000 | 730 | 680 | 640 | 300 |

(NOTE) The mentioned size and scale can be altered to improve the quality performance and capacity of the product without any notice.

VAM90 Pneumatic Isolation Table

※ The model name of VAT product has changed to VAM90



■ Features

A high-precision vibration control table can be made using VAM90 auto-level air spring vibration isolator. The bottom of the air spring is made of steel frame with a height of 700~750 mm on average, and it can be made to order depending on the size of equipment. It maintains the horizontal-level precision of $\pm 1/100\text{mm}$ and the horizontal natural frequency between the air-spring mount and plate of about 2Hz.

■ Usage

- ◆ High-precision measurement equipment, electron microscopes and 3D coordinate measuring machines
- ◆ Environmental measurement equipment and high-precision calibration instruments
- ◆ For high-precision manufacturing machines and high-precision optical testers

VF Foot Rubber Mount (Deflection : 3.5mm)

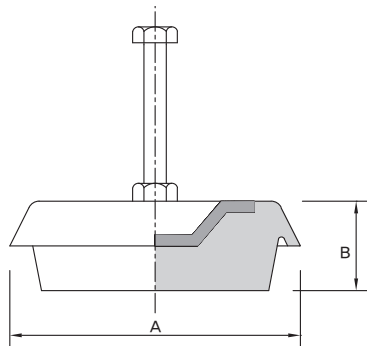
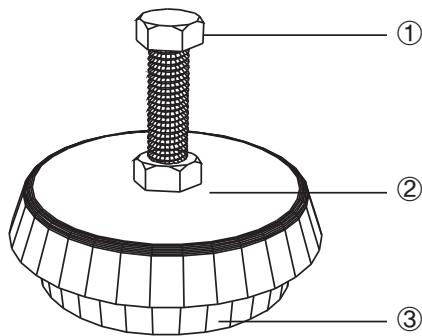
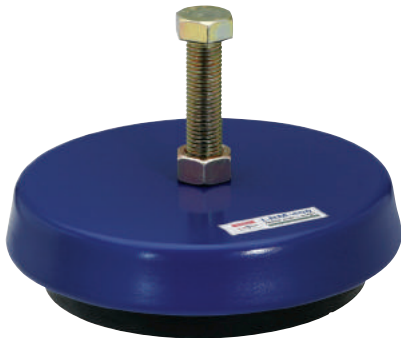

■ Features

The housing is made of strong steel plate with the bolt at the center to control the level when attached on the machine. Its round-shaped floor surface is made of bumpy rubber to isolate impulsive vibration and structure-borne noise, and at the same time, prevent slipping from the structure. It prevents the transfer of vibration from all kinds of machine tools in the most economical manner and reduces vibration acceleration to lengthen the life span of machines.

■ Usage

- ◆ For shock-generating machines like press and forging machines
- ◆ For all kinds of industrial machines, including injection machines, printing machines, timber manufacturers, emergency generators and transformers
- ◆ For machine tools like a lathe, grinder and milling M/C

■ Specification

| No. | Name of Components | Material | Standard |
|-----|--------------------|----------|-----------|
| 1 | Level Bolt | SS400 | KS B 1002 |
| 2 | Housing | SS400 | KS D 3503 |
| 3 | Rubber | CR | KS M 6617 |

■ Dimension & Selection Guide

| Type | Capacity (kgf) | Hardness (A) | Spring Constant (kgf/mm) | Deflection (mm) | Dimension(mm) | | |
|----------|----------------|--------------|--------------------------|-----------------|---------------|----|------------|
| | | | | | A | B | Level Bolt |
| VF-150 | 150 | 60±5 | 43 | 3.5 | 80 | 35 | M10 |
| VF-400 | 400 | | 115 | | 120 | 53 | M12 |
| VF-800 | 800 | | 229 | | 160 | 53 | M16 |
| VF-2000 | 2,000 | | 572 | | 220 | 60 | M20 |
| VF-6000 | 6,000 | | 1715 | | 300 | 70 | M22 |
| VF-10000 | 10,000 | | 2858 | | 400 | 70 | M24 |

(NOTE) The mentioned size and scale can be altered to improve the quality performance and capacity of the product without any notice.

VWM10 Wire Mount

※ The model name of VWM product has changed to VWM10

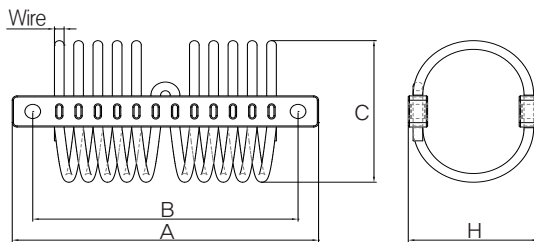
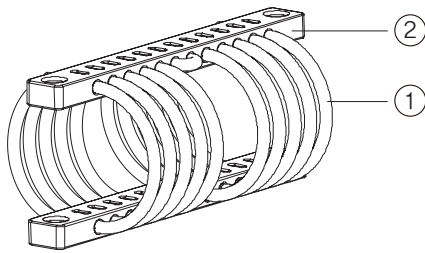

■ Features

VWM10 is capable of isolating vibration using elasticity and attenuation effect of wire rope while absorbing shock. It does not cause surging and minimizes the transmissibility of vibration when it resonates.

■ Usage

- ◆ For equipment that requires vibration isolation and dynamic stability
- ◆ For equipment that needs a buffer
- ◆ For high-precision equipment that is installed inside moving containers
- ◆ For high-precision equipment installed in submarines and ships

■ Specification

| No. | Name of Components | Material | Standard |
|-----|--------------------|----------|-----------|
| 1 | Wire Rope | STS304 | KS D 3514 |
| 2 | Retainer Bar | STS304 | - |

■ Dimension & Selection Guide

| Model | Dimension(mm) | | | | | | Ma.Travel (mm) | Max. Load (kgf) |
|--------------|---------------|-----|-----|------|-----|------|-------------------|--------------------|
| | A | B | C | D | H | Wire | | |
| VWM10-04-100 | | | 45 | | 35 | | 13 | 90 |
| VWM10-04-200 | 125 | 110 | 55 | 6.5 | 45 | 4 | 16 | 50 |
| VWM10-04-300 | | | 65 | | 55 | | 30 | 50 |
| VWM10-05-100 | | | 45 | | 35 | | 13 | 200 |
| VWM10-05-200 | 125 | 110 | 55 | 6.5 | 45 | 5 | 16 | 140 |
| VWM10-05-300 | | | 65 | | 55 | | 30 | 90 |
| VWM10-06-100 | | | 60 | | 50 | | 15 | 240 |
| VWM10-06-200 | 150 | 134 | 70 | 6.5 | 60 | 6 | 25 | 170 |
| VWM10-06-300 | | | 80 | | 70 | | 35 | 110 |
| VWM10-08-100 | | | 80 | | 70 | | 25 | 270 |
| VWM10-08-200 | 190 | 170 | 100 | 8.5 | 90 | 8 | 45 | 200 |
| VWM10-08-300 | | | 120 | | 110 | | 65 | 160 |
| VWM10-10-100 | | | 110 | | 90 | | 50 | 300 |
| VWM10-10-200 | 250 | 230 | 130 | 8.5 | 110 | 10 | 60 | 240 |
| VWM10-10-300 | | | 150 | | 130 | | 75 | 150 |
| VWM10-12-100 | | | 130 | | 110 | | 55 | 600 |
| VWM10-12-200 | 250 | 230 | 150 | 8.5 | 130 | 12 | 70 | 550 |
| VWM10-12-300 | | | 170 | | 150 | | 95 | 400 |
| VWM10-16-100 | | | 130 | | 110 | | 55 | 1300 |
| VWM10-16-200 | 320 | 280 | 150 | 11.0 | 130 | 16 | 70 | 1000 |
| VWM10-16-300 | | | 170 | | 150 | | 95 | 800 |
| VWM10-22-100 | | | 140 | | 130 | | 50 | 1500 |
| VWM10-22-200 | 420 | 380 | 165 | 12.0 | 150 | 22 | 70 | 1300 |
| VWM10-22-300 | | | 190 | | 170 | | 90 | 1100 |

(NOTE) The mentioned size and scale can be altered to improve the quality performance and capacity of the product without any notice.

VWM20 Wire Mount

※ The model name of VWR product has changed to VWM20

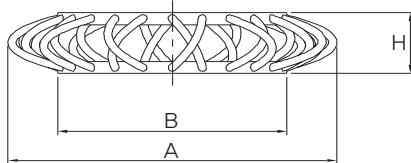
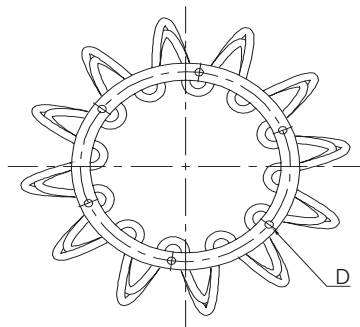
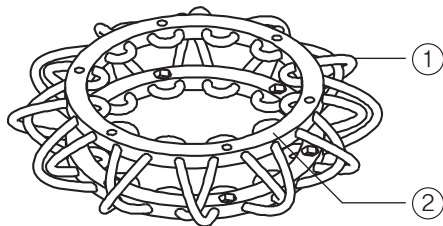

■ Features

It is a product that can work as an isolator that isolates vibration using elasticity and attenuation effects of wire rope and an absorber, which eases shock. Its circular Mount shape allows it to minimize coupling with the same stiffness for lateral load. It is effective in attenuation and blocking high frequency over 100Hz, which means that it minimizes transfer of vibration without surging. It is superior that coil spring or neoprene Rubber in terms of resistance against corrosion, heat, ozone and oil and moreover, it can make up for disadvantages of coil spring being lack in attenuation and rubber having the natural frequency.

■ Usage

- ◆ For equipment that needs vibration isolation and dynamic stability
- ◆ For equipment that needs shock-absorber
- ◆ For high-precision equipment that is installed inside the mobile container
- ◆ Used to isolate high-frequency vibration from, for example, transformer
- ◆ For super-precision machine tool
- ◆ For vibration damping of high-precision tester
- ◆ Used to control vertical/horizontal vibration

■ Specification

| No. | Name of Components | Material |
|-----|--------------------|----------|
| 1 | Wire Rope | STS304 |
| 2 | Retainer Bar | STS304 |

■ Dimension & Selection Guide

| Type | Dimension(mm) | | | | Max.Travel (mm) | Max. Load (kgf) |
|-----------|---------------|-----|----|-----|--------------------|--------------------|
| | A | B | H | D | | |
| VWM20-90 | 170 | 090 | 50 | 6.2 | 30 | 30 |
| VWM20-120 | 200 | 120 | | | | 60 |
| VWM20-170 | 250 | 170 | | | | 100 |
| VWM20-230 | 310 | 230 | | | | 200 |

(NOTE) The mentioned size and scale can be altered to improve the quality performance and capacity of the product without any notice.

VWM51 Wire-Spring Mount (Deflection : 25mm)

※ The model name of VWA product has changed to VWM51

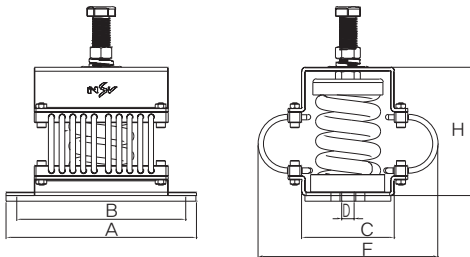
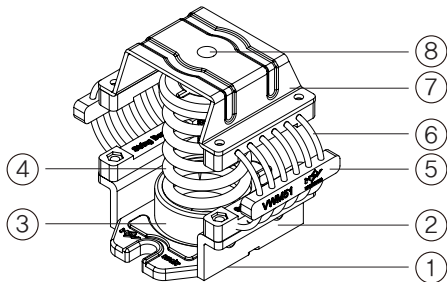

■ Features

VWM51 offers elasticity of coil spring and excellent attenuation effect of wire rope, ensuring vibration isolation and dynamic stabilization of equipment.
Enhanced strength of wire mount helps bear large loads
Enhanced strength of wire mount helps bear large loads

■ Usage

- ◆ For equipment that requires vibration isolation and dynamic stability
- ◆ For equipment that needs a buffer
- ◆ For reciprocating compressors and steam blowers
- ◆ For equipment that needs to control noise directing the floor right below

■ Specification

| No. | Name of Components | Material | Standard |
|-----|--------------------|-----------|-----------|
| 1 | Lower Non Skid Pad | CR | KS M 6617 |
| 2 | Lower Housing | SS400 | KS D 3503 |
| 3 | Spring Seat | CR | KS M 6617 |
| 4 | Coil Spring | SUP9 | KS B 2402 |
| | | HSW3 | KS B 2403 |
| 5 | Retainer Bar | E-Plastic | - |
| 6 | Wire Rope | STS304 | KS D 3514 |
| 7 | Upper housing | SS400 | KS D 3503 |
| 8 | Level Bolt | SS400 | KS B 1002 |

■ Dimension & Selection Guide

| Type | Capacity (kgf) | Spring Constant (kgf/mm) | Color | Dimension(mm) | | | | | | |
|------------|----------------|--------------------------|--------|---------------|-----|-----|----|-----|-----|---------------|
| | | | | A | B | C | D | E | H | Leveling Bolt |
| VWM51-100 | 100 | 4.0 | Blue | 138 | 108 | 89 | 13 | 170 | 145 | M16×80 |
| VWM51-150 | 150 | 6.0 | Brown | | | | | | | |
| VWM51-200 | 200 | 8.0 | White | | | | | | | |
| VWM51-300 | 300 | 12.0 | Orange | | | | | | | |
| VWM51-400 | 400 | 16.0 | Pink | 192 | 162 | 112 | 13 | 180 | 165 | M20×90 |
| VWM51-500 | 500 | 20.0 | Green | | | | | | | |
| VWM51-600 | 600 | 24.0 | Blue | | | | | | | |
| VWM51-750 | 750 | 30.0 | Black | | | | | | | |
| VWM51-1000 | 1000 | 40.0 | Yellow | | | | | | | |
| VWM51-1200 | 1200 | 48.0 | Red | | | | | | | |
| VWM51-1500 | 1500 | 60.0 | Brown | | | | | | | |

(NOTE) The specification and data are subject to change without prior notice for improvement of product performance and quality.

VWM52 Wire-Spring Mount (Deflection : 50mm)

※ The model name of VWA product has changed to VWM52

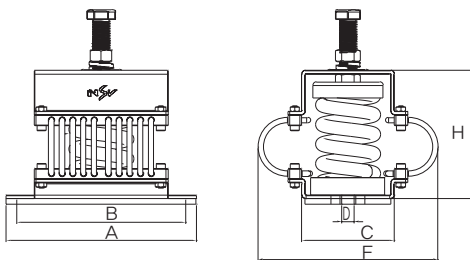
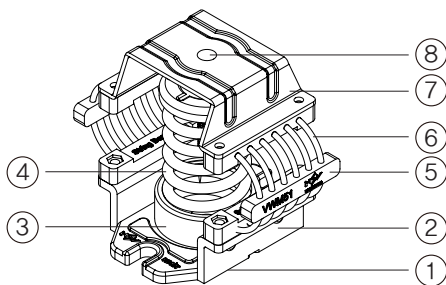

■ Features

It is a wire spring mount, has the same feature and purpose as VWM51 TYPE, but with static displacement of spring being 50mm, used when necessary to operate in quiet and calm manner of equipments requiring reciprocating compressor, steam blower, vibration reduction ability and dynamic stability.

■ Usage

- ◆ Reciprocating compressor, steam blower
- ◆ Used in high efficiency vibration reduction of equipments requiring vibration ability and dynamic stability.
- ◆ Used in high efficiency vibration reduction requiring buffer medium
- ◆ Used in high efficiency vibration reduction when necessary to remove noise from direct underneath layer

■ Specification

| No. | Name of Components | Material | Standard |
|-----|--------------------|-----------|-----------|
| 1 | Lower Non Skid Pad | CR | KS M 6617 |
| 2 | Lower Housing | SS400 | KS D 3503 |
| 3 | Spring Seat | CR | KS M 6617 |
| 4 | Coil Spring | SUP9 | KS B 2402 |
| | | HSW3 | KS B 2403 |
| 5 | Retainer Bar | E-Plastic | - |
| 6 | Wire Rope | STS304 | KS D 3514 |
| 7 | Upper housing | SS400 | KS D 3503 |
| 8 | Level Bolt | SS400 | KS B 1002 |

■ Dimension & Selection Guide

| Type | Capacity (kgf) | Spring Constant (kgf/mm) | Color | Dimension(mm) | | | | | | |
|------------|----------------|--------------------------|--------|---------------|-----|-----|----|-----|-----|---------------|
| | | | | A | B | C | D | E | H | Leveling Bolt |
| VWM52-100 | 100 | 2.0 | Blue | 216 | 186 | 139 | 13 | 200 | 185 | M20×90 |
| VWM52-150 | 150 | 3.0 | Brown | | | | | | | |
| VWM52-200 | 200 | 4.0 | White | | | | | | | |
| VWM52-300 | 300 | 6.0 | Orange | | | | | | | |
| VWM52-400 | 400 | 8.0 | Pink | | | | | | | |
| VWM52-500 | 500 | 10.0 | Green | | | | | | | |
| VWM52-600 | 600 | 12.0 | Blue | | | | | | | |
| VWM52-750 | 750 | 15.0 | Black | | | | | | | |
| VWM52-1000 | 1000 | 20.0 | Yellow | | | | | | | |
| VWM52-1200 | 1200 | 24.0 | Red | | | | | | | |
| VWM52-1500 | 1500 | 30.0 | Brown | | | | | | | |

(NOTE) The specification and data are subject to change without prior to for improvement of product performance and quality.

VWM51/VWM52 Wire-Spring Mount

■ VWM51 – Test Data

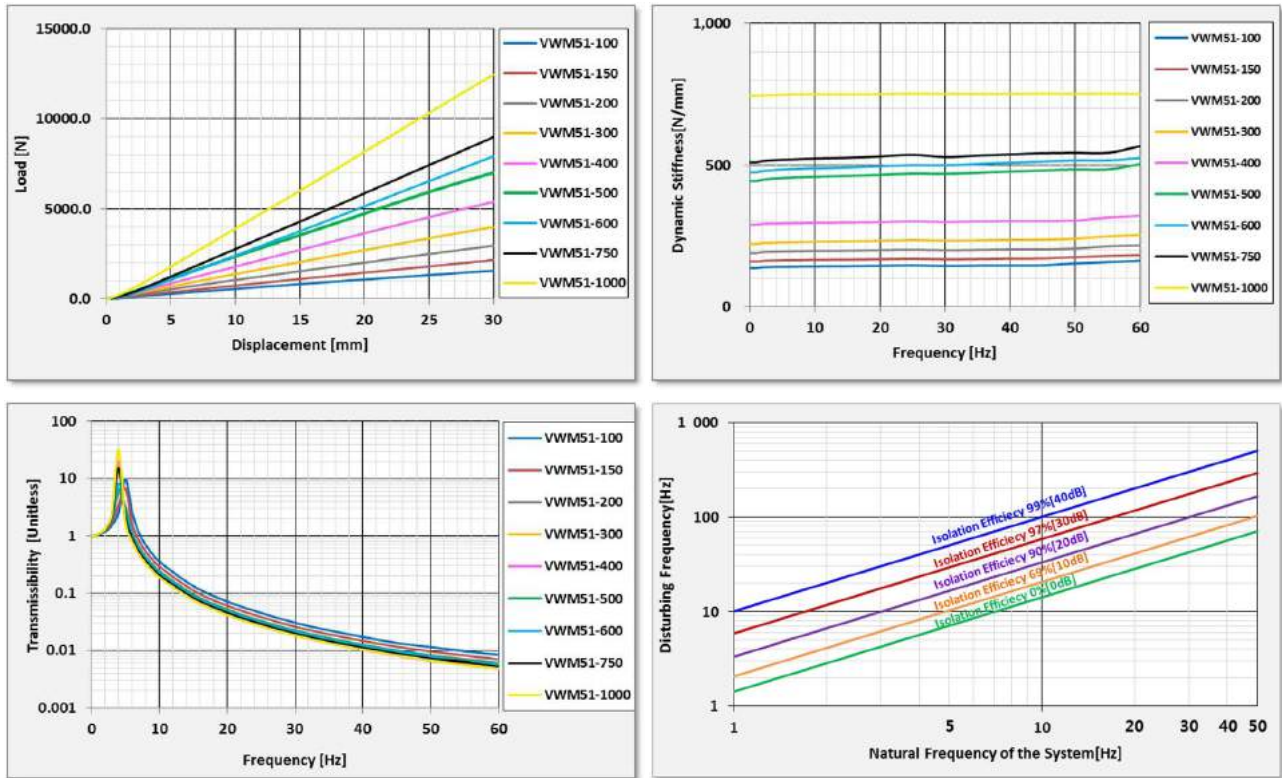

■ VWM52 – Test Data

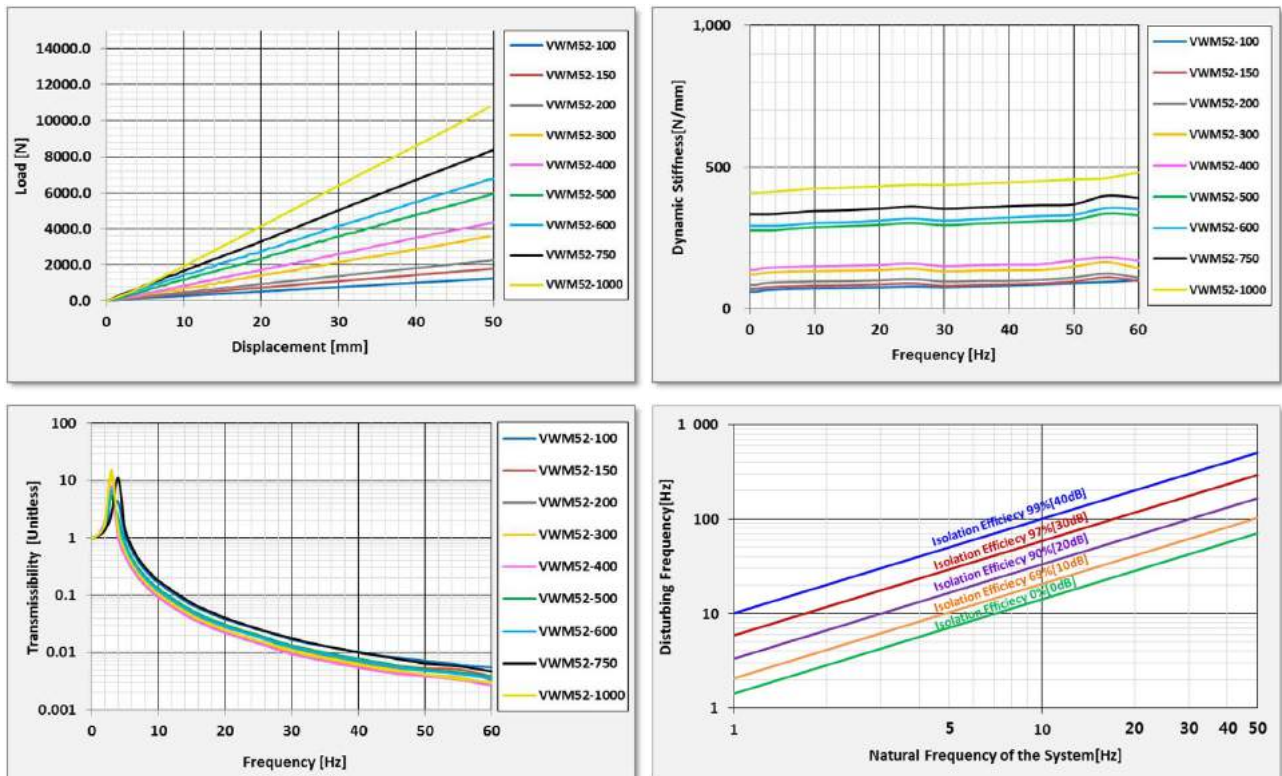

VWM62 Wire-Spring Mount (Deflection : 50mm)



※ The model name of VWS product has changed to VWM62

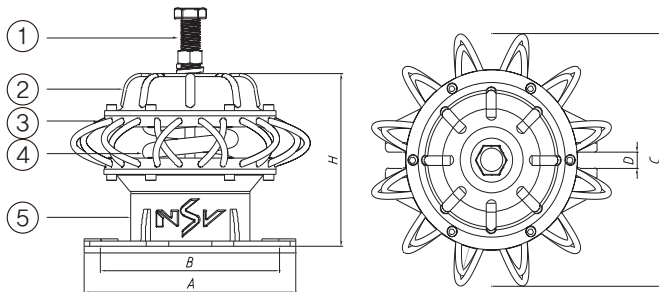
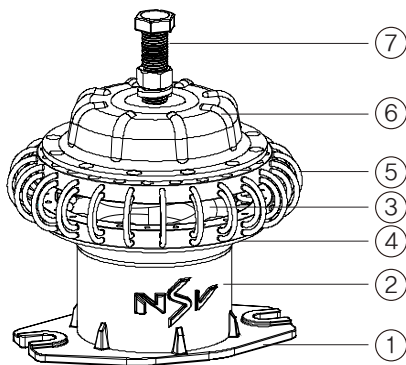

■ Features

VWM62 offers elasticity of coil spring and excellent attenuation effect of wire rope, ensuring vibration isolation and dynamic stabilization of equipment.
enhanced strength of wire mount helps bear large loads

■ Usage

- ◆ For equipment that requires vibration isolation and dynamic stability
- ◆ For equipment that needs a buffer
- ◆ For equipment that needs horizontal elasticity
- ◆ For cooling towers, reciprocating compressors and steam blowers
- ◆ For equipment that needs to control noise directing the floor right below

■ Specification

| No. | Name of Components | Material | Standard |
|-----|--------------------|----------|-----------|
| 1 | Lower Non Skid Pad | CR | KS M 6617 |
| 2 | Lower Housing | STS304 | - |
| 3 | Coil Spring | SUP9 | KS B 2402 |
| | | HSW3 | KS B 2403 |
| 4 | Retainer Bar | STS304 | - |
| 5 | Wire Rope | STS304 | KS D 3514 |
| 6 | Upper housing | STS304 | - |
| 7 | Level Bolt | SS400 | KS B 1002 |

■ Dimension & Selection Guide

| Type | Capacity (kgf) | Spring Constant (kgf/mm) | Color | Dimension(mm) | | | | | | |
|------------|----------------|--------------------------|--------|---------------|-----|-----|----|-----|-----|---------------|
| | | | | A | B | C | D | E | H | Leveling Bolt |
| VWM62-100 | 100 | 2 | Blue | 210 | 180 | 135 | 15 | 235 | 165 | M16×80 |
| VWM62-150 | 150 | 3 | Brown | | | | | | | |
| VWM62-200 | 200 | 4 | White | | | | | | | |
| VWM62-300 | 300 | 6 | Orange | | | | | | | |
| VWM62-400 | 400 | 8 | Pink | | | | | | | |
| VWM62-500 | 500 | 10 | Green | | | | | | | |
| VWM62-600 | 600 | 12 | Blue | | | | | | | |
| VWM62-750 | 750 | 15 | Black | | | | | | | |
| VWM62-1000 | 1000 | 20 | Yellow | | | | | | | |
| VWM62-1200 | 1200 | 24 | Red | | | | | | | |
| VWM62-1500 | 1500 | 30 | Black | | | | | | | |

(NOTE) The mentioned size and scale can be altered to improve the quality performance and capacity of the product without any notice.

Seismic
Control



ISO 9001/ISO 14001
OHSAS 18001
MADE IN KOREA

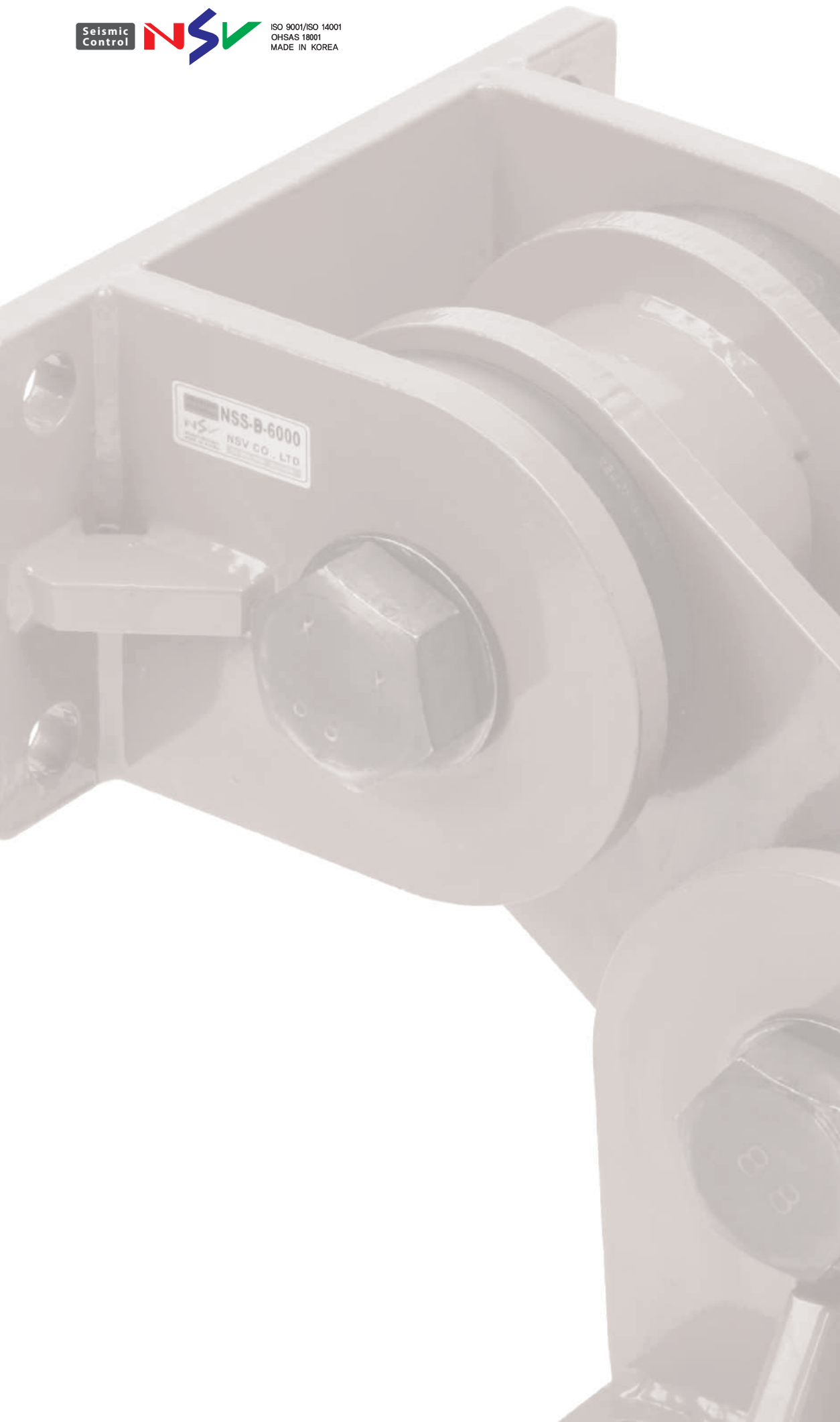

SEISMIC CONTROL

NSS-A

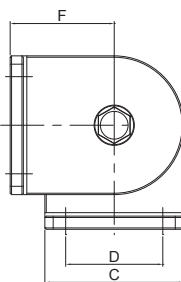
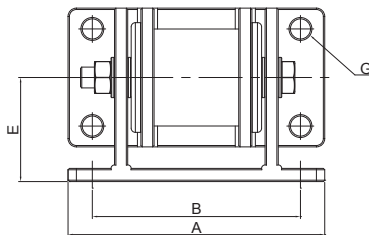
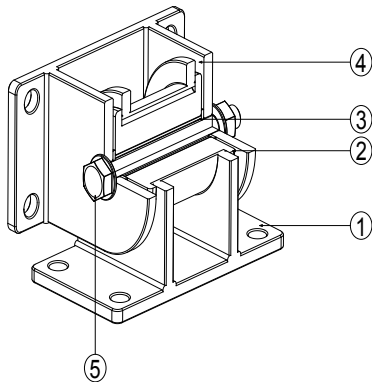

■ Features

There is a bracket inside the seismic snubber to install 20mm or thicker neoprene element and 2 anchors or more. In general, it is desirable to install 6 or more with a structural base rather than direct attachment to HVAC. A spacer pipe is installed to maintain the clearance. The spacer pipe will be removed after installation.

■ Specification

| No. | Name of Components | Material | Standard |
|-----|--------------------|----------|-----------|
| 1 | Upper Housing | SS400 | KS D 3504 |
| 2 | Sesimic Rubbver | CR | KS M 6617 |
| 3 | Spacer Pipe | SS400 | KS D 3503 |
| 4 | Upper Housing | SS400V | KS D 3504 |
| 5 | Shaft Bolt | SS400 | KS B 1012 |

■ Usage

For earthquake resistance of HVAC and other equipment

■ Dimension & Selection Guide

| Type | Capacity (kgf) | Weight (kg) | Dimension(mm) | | | | | | |
|-----------|----------------|-------------|---------------|-----|-----|----|-----|-----|-----|
| | | | A | B | C | D | E | F | H |
| NSS-300 | 300 | 1.8 | 150 | 128 | 73 | 11 | 66 | - | 102 |
| NSS-600 | 600 | 3.6 | 200 | 172 | 110 | 13 | 100 | - | 146 |
| NSS-2000 | 2,000 | 9.1 | 320 | 290 | 175 | 16 | 127 | 128 | 214 |
| NSS-6000 | 6,000 | 28 | 370 | 330 | 200 | 25 | 146 | 140 | 246 |
| NSS-12000 | 12,000 | 43 | 405 | 360 | 280 | 32 | 203 | 210 | 343 |

(NOTE) The mentioned size and scale can be altered to improve the quality performance and capacity of the product without any notice.

NSS-B

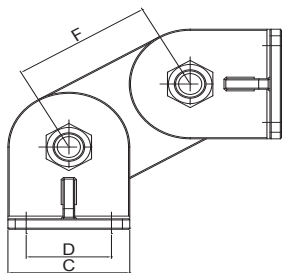
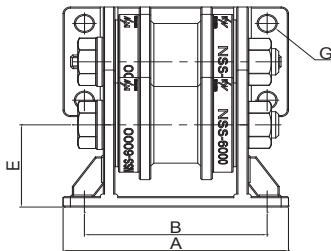
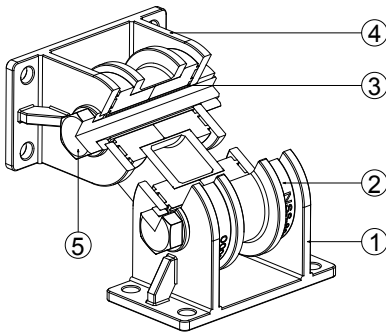

■ Features

There is a bracket inside the seismic snubber to install 20mm or thicker neoprene element and 2 anchors or more. In general, it is desirable to install 6 or more with a structural base rather than direct attachment to HVAC. Height of articulated seismic snubber is adjustable for easy installation, and a spacer pipe will be installed to maintain the clearance. After the installation, the spacer pipe will be removed.

■ Specification

| No. | Name of Components | Material | Standard |
|-----|--------------------|----------|-----------|
| 1 | Lower Housing | SS400 | KS D 3504 |
| 2 | Sesimic Rubbver | CR | KS M 6617 |
| 3 | Spacer Pipe | SS400 | KS D 3503 |
| 4 | Upper Housing | SS400 | KS D 3504 |
| 5 | Shaft Bolt | SS400 | KS B 1012 |

■ Usage

- ◆ For seismic of HVAC and other equipment
- ◆ For seismic of equipment requiring installation height adjustment of snubber

■ Dimension & Selection Guide

| Type | Capacity (kgf) | Dimension(mm) | | | | | | |
|-------------|----------------|---------------|-----|-----|-----|-----|-----|----|
| | | A | B | C | D | E | F | G |
| NSS-B-300 | 300 | 150 | 128 | 73 | - | 66 | 103 | 14 |
| NSS-B-600 | 600 | 200 | 172 | 110 | - | 100 | 140 | 14 |
| NSS-B-2000 | 2,000 | 320 | 255 | 175 | 128 | 127 | 205 | 4 |
| NSS-B-6000 | 6,000 | 370 | 305 | 200 | 140 | 146 | 230 | 16 |
| NSS-B-12000 | 12,000 | 405 | 405 | 280 | 210 | 203 | 310 | 22 |

(NOTE) The mentioned size and scale can be altered to improve the quality performance and capacity of the product without any notice.

NSS-C

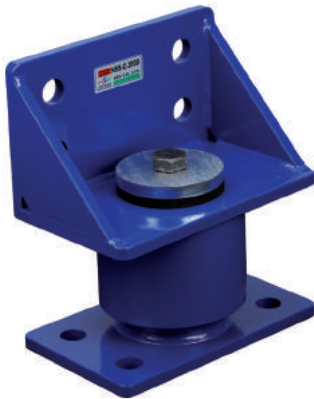

■ Features

There is a bracket inside the seismic snubber to install 20mm or thicker neoprene element and 2 anchors or more. In general, it is desirable to install 6 or more with a structural base rather than direct attachment to HVAC. It is easy to install and has the circular neoprene element around the steel pipe so large load can be borne with the relatively small size.

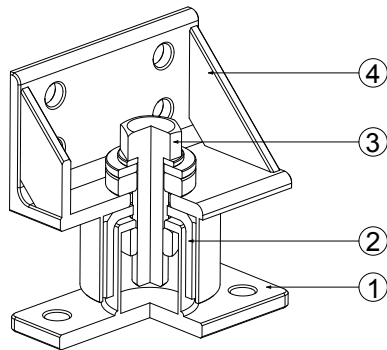

■ Specification

| No. | Name of Components | Material | Standard |
|-----|--------------------|----------|-----------|
| 1 | Lower Housing | SS400 | KS D 3504 |
| 2 | Sesimic Rubbver | CR | KS M 6617 |
| 3 | Shaft Bolt | SS400 | KS B 1012 |
| 4 | Upper Housing | SS400 | KS D 3504 |

■ Usage

For seismic of HVAC and other equipment

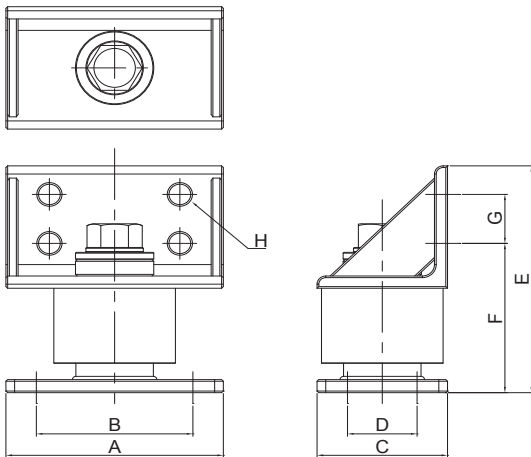

■ Dimension & Selection Guide

| Type | Capacity (kgf) | Dimension(mm) | | | | | | | |
|------------|----------------|---------------|-----|-----|-----|-----|-----|-----|----|
| | | A | B | C | D | E | F | G | H |
| NSS-C-600 | 600 | 200 | 140 | 100 | 50 | 200 | 160 | 60 | 14 |
| NSS-C-2000 | 2,000 | 250 | 180 | 150 | 80 | 280 | 185 | 60 | 25 |
| NSS-C-6000 | 6,000 | 300 | 230 | 200 | 110 | 360 | 200 | 100 | 29 |

(NOTE) The mentioned size and scale can be altered to improve the quality performance and capacity of the product without any notice.

NSS-D

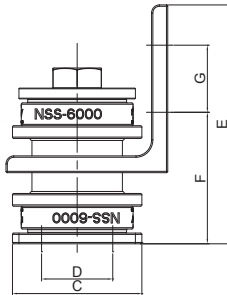
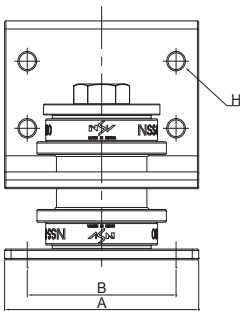
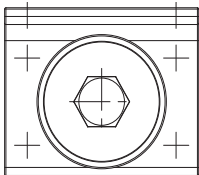
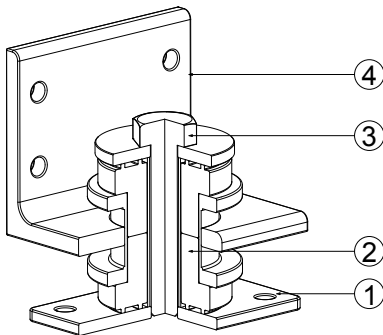
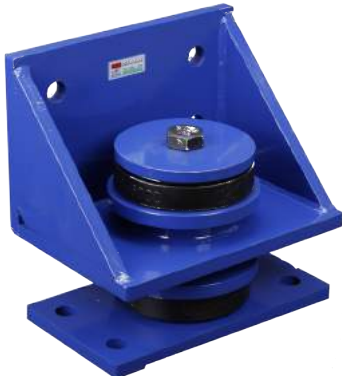

■ Features

There is a bracket inside the seismic snubber to install 20mm or thicker neoprene element and 2 anchors or more. In general, it is desirable to install 6 or more with a structural base rather than direct attachment to HVAC.

It is easy to install and has the circular neoprene element around the steel pipe so large load can be borne with the relatively small size.

■ Specification

| No. | Name of Components | Material | Standard |
|-----|--------------------|----------|-----------|
| 1 | Lower Housing | SS400 | KS D 3504 |
| 2 | Sesimic Rubbver | CR | KS M 6617 |
| 3 | Shaft Bolt | SS400 | KS B 1012 |
| 4 | Upper Housing | SS400 | KS D 3504 |

■ Usage

For seismic of HVAC and other equipment

■ Dimension & Selection Guide

| Type | Capacity (kgf) | Dimension(mm) | | | | | | | |
|------------|----------------|---------------|-----|-----|-----|-----|-----|-----|----|
| | | A | B | C | D | E | F | G | H |
| NSS-D-600 | 600 | 200 | 140 | 100 | 50 | 200 | 160 | 60 | 14 |
| NSS-D-2000 | 2,000 | 250 | 180 | 150 | 80 | 280 | 185 | 60 | 25 |
| NSS-D-6000 | 6,000 | 300 | 230 | 200 | 110 | 360 | 200 | 100 | 29 |

(NOTE) The mentioned size and scale can be altered to improve the quality performance and capacity of the product without any notice.

NSS-E

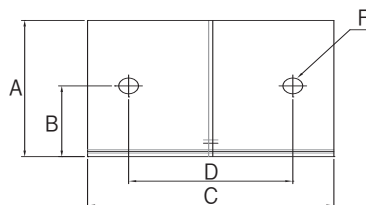
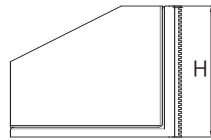
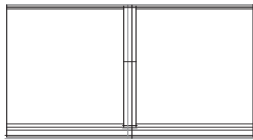
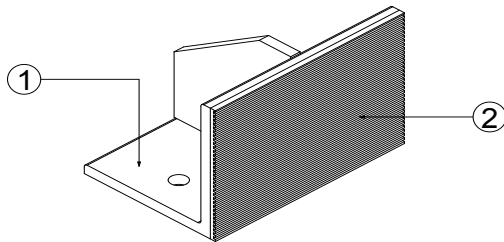

■ Features

This stopper is installed with about 6mm distance from the subject device. During normal vibration, it doesn't effect the anti-vibration efficiency of the device. However, when there is an earthquake, the stopper prevents movements and falls.

The product has a simple structure, and can be applied to almost all devices as there is no limitation on installation. The process of installation is also easy. (Preventing movements)

■ Specification

| No. | Name of Components | Material | Standard |
|-----|--------------------|----------|-----------|
| 1 | Sunbber Housing | SS400 | KS D 3504 |
| 2 | Sesimic Rubbver | CR | KS M 6617 |

■ Usage

For seismic of HVAC and other equipment

■ Dimension & Selection Guide

| Type | Capacity (kgf) | Dimension(mm) | | | | | |
|------------|----------------|---------------|----|-----|-----|----|-----|
| | | A | B | C | D | E | H |
| NSS-E-100 | 100 | 98 | 40 | 130 | 100 | 12 | 75 |
| NSS-E-200 | 200 | 98 | 40 | 150 | 110 | 14 | 75 |
| NSS-E-400 | 400 | 108 | 45 | 180 | 130 | 18 | 75 |
| NSS-E-800 | 800 | 108 | 45 | 180 | 130 | 22 | 75 |
| NSS-E-1500 | 1,500 | 133 | 58 | 200 | 140 | 26 | 90 |
| NSS-E-3000 | 3,000 | 158 | 70 | 240 | 170 | 32 | 100 |
| NSS-E-4000 | 4,000 | 158 | 70 | 300 | 220 | 38 | 100 |

(NOTE) The mentioned size and scale can be altered to improve the quality performance and capacity of the product without any notice.

NSS-F

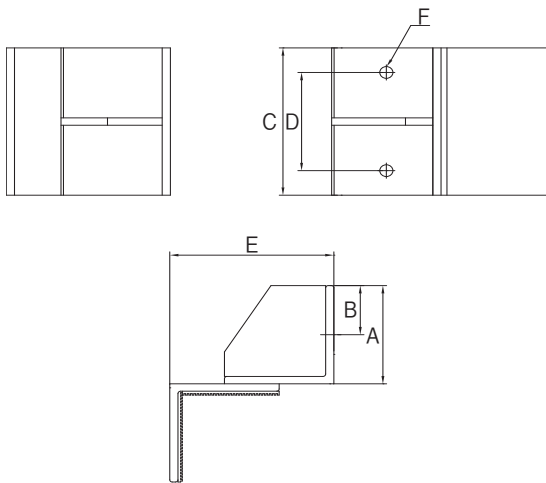
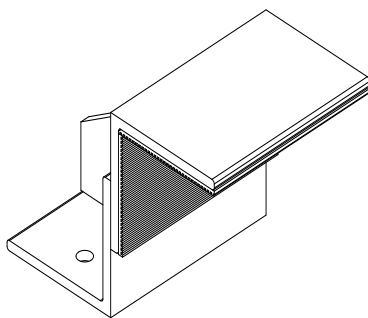

■ Features

This stopper is installed with about 6mm distance from the subject device. During normal vibration, it doesn't effect the anti-vibration efficiency of the device. However, when there is an earthquake, the stopper prevents movements and falls.

The product has a simple structure, and can be applied to almost all devices as there is no limitation on installation. The process of installation is also easy. (Preventing movements)

■ Specification

| No. | Name of Components | Material | Standard |
|-----|--------------------|----------|-----------|
| 1 | Sunbber Housing | SS400 | KS D 3504 |
| 2 | Seismic Rubbver | CR | KS M 6617 |

■ Usage

For seismic of HVAC and other equipment

■ Dimension & Selection Guide

| Type | Capacity (kgf) | Dimension(mm) | | | | | |
|------------|----------------|---------------|----|-----|-----|----|-----|
| | | A | B | C | D | E | H |
| NSS-F-100 | 100 | 98 | 40 | 130 | 100 | 12 | 115 |
| NSS-F-200 | 200 | 98 | 40 | 150 | 110 | 14 | 115 |
| NSS-F-400 | 400 | 108 | 45 | 180 | 130 | 18 | 115 |
| NSS-F-800 | 800 | 108 | 45 | 180 | 130 | 22 | 115 |
| NSS-F-1500 | 1,500 | 113 | 58 | 200 | 140 | 26 | 130 |
| NSS-F-3000 | 3,000 | 158 | 70 | 240 | 170 | 32 | 140 |
| NSS-F-4000 | 4,000 | 158 | 70 | 300 | 220 | 38 | 140 |

(NOTE) The mentioned size and scale can be altered to improve the quality performance and capacity of the product without any notice.

NSS-G



■ Features

When a duct or pipe is hung on a ceiling with a stud bolt, a member is attached to the stud bolt with a stiffener in order to improve the stiffness. The system consists of a stud bolt, stiffness member, and rod stiffener.

■ Dimension & Selection Guide

| Type | Cable Diameter (mm) | Cable Length (mm) | Cable Maximum Tension (kgf) |
|---------|---------------------|-------------------|-----------------------------|
| Cable A | 3 | 5 | 450 |
| Cable B | 5 | 5 | 950 |
| Cable C | 6 | 5 | 1500 |

(NOTE) The mentioned size and scale can be altered to improve the quality performance and capacity of the product without any notice.

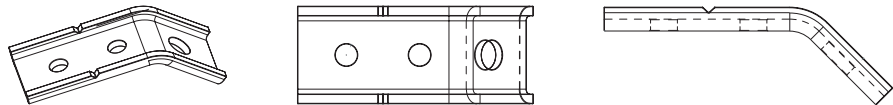

NSS-H



■ Features

When a duct or pipe is hung on a ceiling with a stud bolt, a member is attached to the stud bolt with a stiffener in order to improve the stiffness. The system consists of a stud bolt, stiffness member, and rod stiffener.

■ Dimension & Selection Guide

| Type | Angle Size | Hanger Rod Size |
|-----------------|--------------|--------------------|
| Seismic Rod - A | 25 x 25 x 3T | 3/8", 1/2", 5/8" |
| Seismic Rod - B | 40 x 40 x 5T | 3/4", 7/8", 1 1/8" |

(NOTE) The mentioned size and scale can be altered to improve the quality performance and capacity of the product without any notice.

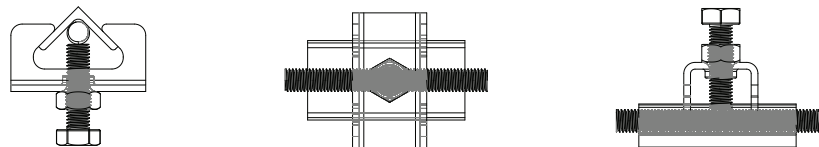

NSS-I



■ Features

When a duct or pipe is hung on a ceiling with a stud bolt, a member is attached to the stud bolt with a stiffener in order to improve the stiffness. The system consists of a stud bolt, stiffness member, and rod stiffener.

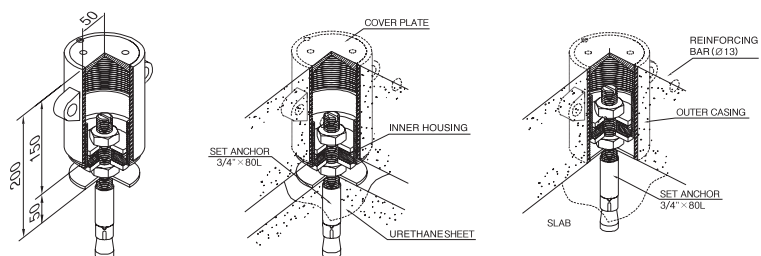

NOISE control



RECTANGULAR TYPE SILENCER



HYBRID TYPE SILENCER

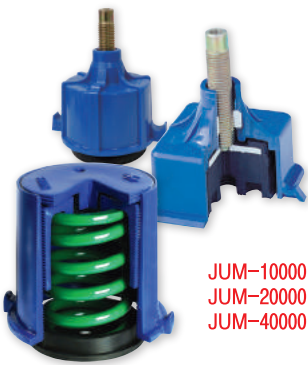

JUM-10000
JUM-20000
JUM-40000

PO-MAT

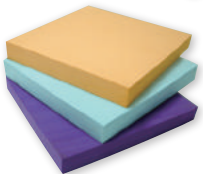

HD-MAT

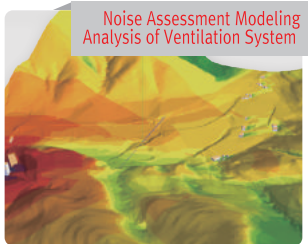

Noise Assessment Modeling
Analysis of Ventilation System

SHOCK control



WHA Series



WHA-3000 Series



WHA-4000 Series



WHA-6000 Series

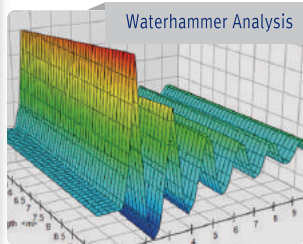

Waterhammer Analysis

VIBRATION control



FSL2



NFC10S
NFC10
NFC20



VM-2000
VM-4000
VC

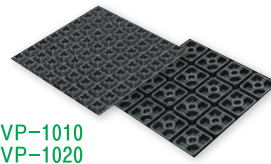

VP-1010
VP-1020



VWM51/52
VWM62
VWM10

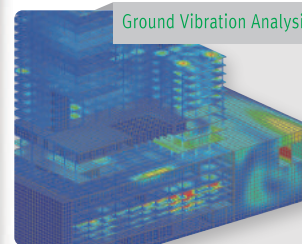

Ground Vibration Analysis

SEISMIC control



NSS-A



NSS-B

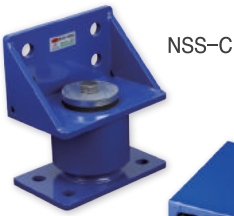

NSS-C

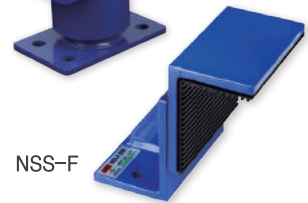

NSS-F



NSS-G

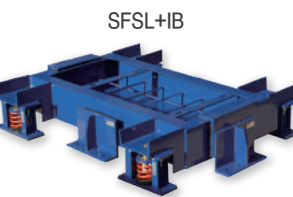

SFSL+IB

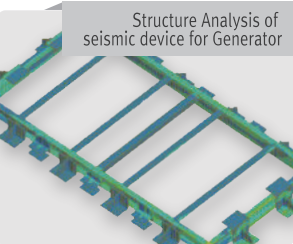

Structure Analysis of
seismic device for Generator

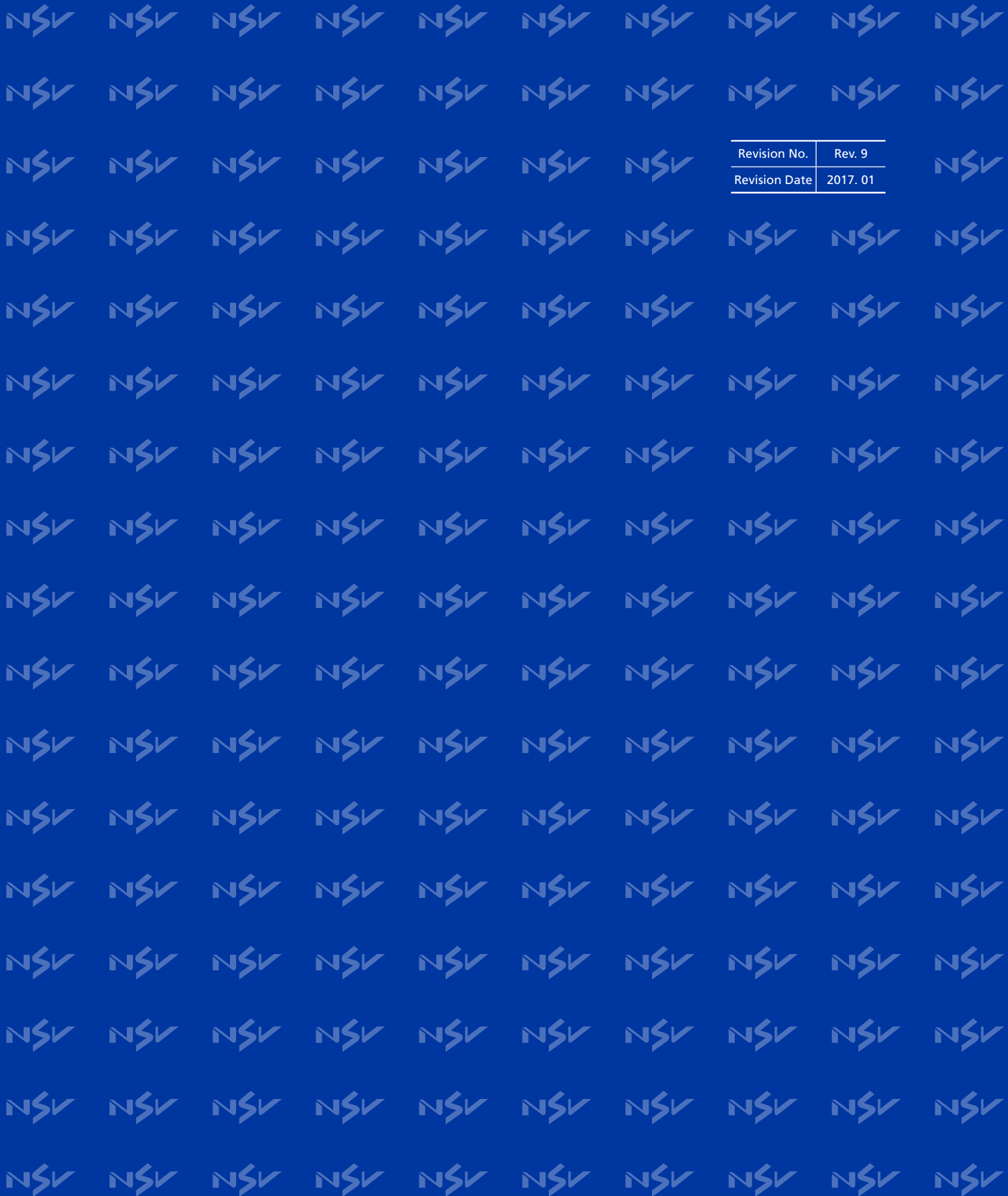

| | |
|---------------|----------|
| Revision No. | Rev. 9 |
| Revision Date | 2017. 01 |



NSV Co., Ltd.
Noise, Shock & Vibration Control

엔에스브이기술연구소
NSV R&D Center No.981590

SEOUL OFFICE 3F, 28, Hyoryeong-ro 55-gil, Seocho-gu, Seoul, Republic of Korea
 HEAD OFFICE & INCHEON FACTORY 89, Namdong-daero 36beon-gil, Namdong-gu, Incheon, Republic of Korea
 R&D CENTER 89, Namdong-daero 36beon-gil, Namdong-gu, Incheon, Republic of Korea

TEL +82-2-598-1988 FAX +82-2-598-1989
 TEL +82-32-812-2015 FAX +82-32-812-2014
 TEL +82-32-812-2015 FAX +82-32-812-2014

www.nsv.co.kr E-mail overseas@nsv.co.kr

