

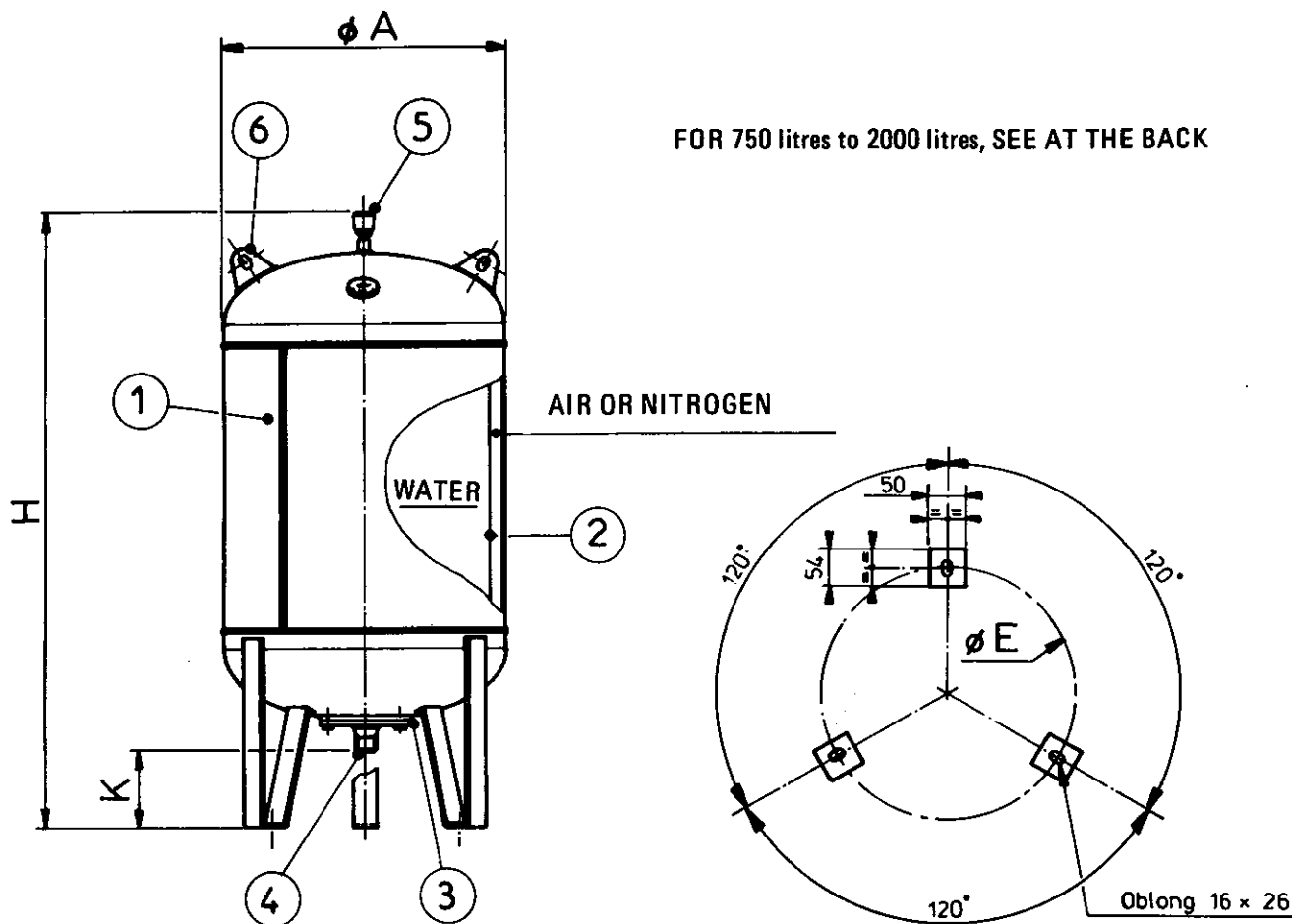

ANTI-WATER HAMMER – WATER PRESSURE BOOSTER – REGULATION

(France)



FOR 750 litres to 2000 litres, SEE AT THE BACK

- 1 Welded steel plate tank - Inside and outside paint protection
- 2 Interchangeable bladder (Butyl)
- 3 Bladder lock flange
- 4 Standard water outlet 40/49 (gaz) - Option 50/60 Or 80/90
- 5 Inflator protected valve male thread 1/2" Gaz
- 6 Lifting eye

CAPACITY	REFER.	Ø A	H	Ø E	WEIGHT (kg)
100 litres	20210 x	630	760	560	40
200 litres	20211 x	630	1095	560	60
300 litres	20212 x	630	1435	560	85
500 litres	20213 x	630	2065	560	130

OUTLET	REFERENCE	K	WEIGHT (kg)
40 x 49	7113 SIB	170	2,5
50 x 60	7676 SIB	170	2,6
8C x 90	7675 SIB	140	2,7

新法機械有限公司
 NEW WAY ENGINEERING CO., LTD.
 香港九龍新蒲崗六合街8號六合工業大廈22字樓F座
 FLAT F, 22/F, LUK HOP INDUSTRIAL BUILDING,
 8 LUK HOP STREET, SAN PO KONG, KOWLOON, H.K.
 Tel : 2325 6892, 2325 7196 Fax No.: (852) 2322 1768
 E-mail : info@newway.com.hk

These dimensions can be modified by the manufacturer without previous notice.

1/01/84

EXPANSION VESSEL HYDROFLEX

SERVICE PRESSURE 10 BARS – TEST PRESSURE 15 BARS
 MAXIMUM FUNCTIONING TEMPERATURE , 110°C



ANTI-WATER HAMMER – WATER PRESSURE BOOSTER – REGULATION

Charlotte sa

(France)

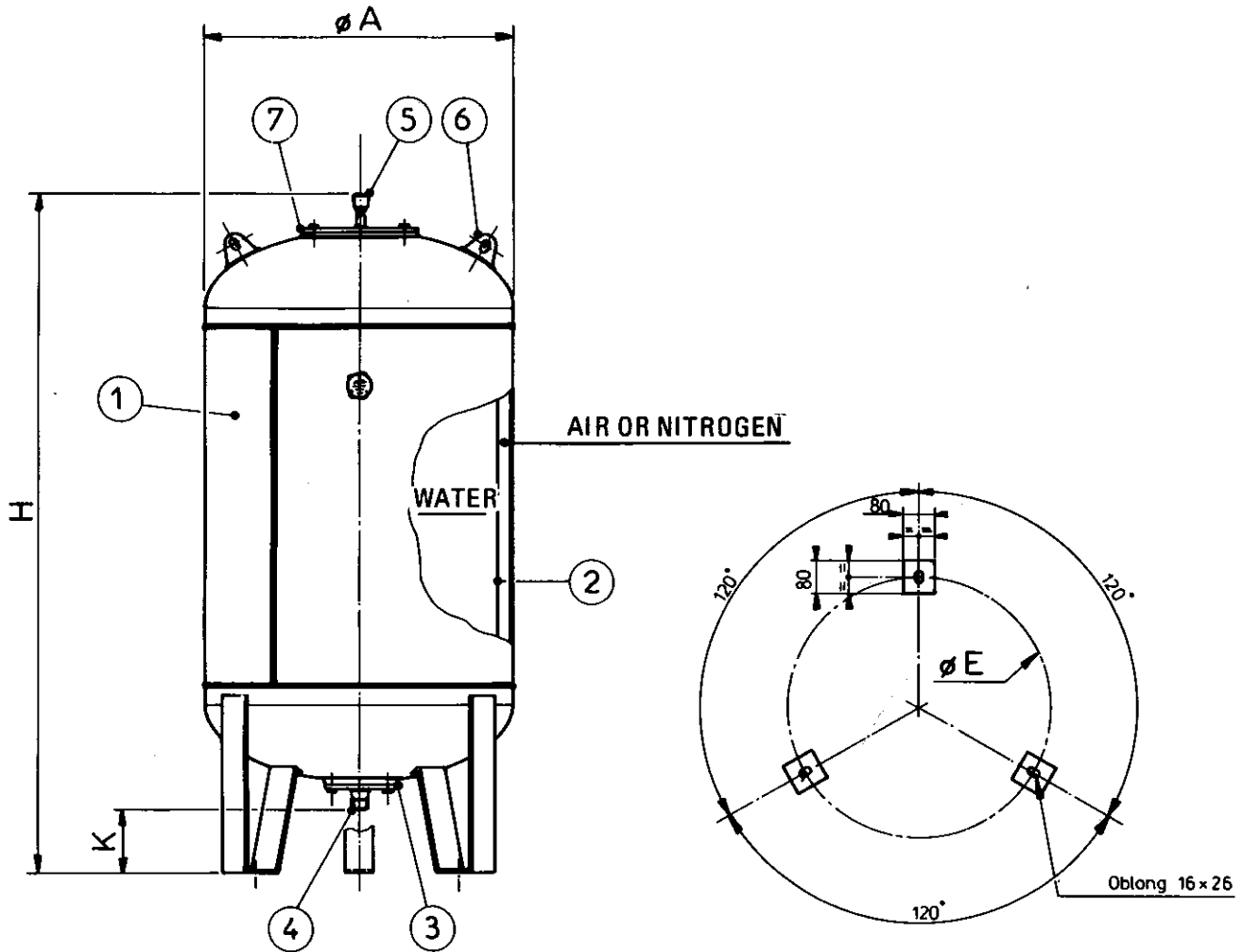

- 1 Welded steel plate tank - Inside and outside paint protection
- 2 Interchangeable bladder (Butyl)
- 3 Bladder lock flange
- 4 Standard water outlet 40/49 (gaz) - Option 50/60 Or 80/90
- 5 Inflator protected valve male thread 1/2" Gaz
- 6 Lifting eye
- 7 Inspection hole with cover special air seal.

CAPACITY	REFER.	ϕA	H	ϕE	WEIGHT (kg)
750 litres	20214 x	850	1900	755	210
1000 litres	20215 x	850	2310	755	245
1500 litres	20216 x	1000	2470	905	350
2000 litres	20217 x	1000	3130	905	460

OUTLET	REFERENCE	K	WEIGHT (kg)
40 x 49	7113 SIB	170	2,5
50 x 60	7676 SIB	170	2,6
80 x 90	7675 SIB	140	2,7

These dimensions can be modified by the manufacturer without previous notice.

1/01/84

EXPANSION VESSEL HYDROFLEX

SERVICE PRESSURE 10 BARS – TEST PRESSURE 15 BARS
 MAXIMUM FUNCTIONNING TEMPERATURE : 110°C